

ESPAÑOL



Producto Catálogo

U.S Standard LV NEMA Motor

(Severe Duty, IEEE841, Explosion proof)



EMPORIUMENERGY

NOR
NOR Consulting, LLC



Tabla de Contenido

Product Features

Pages	HD HYUNDAI Models	LV Motor Types
09	HES, HHI Model	NEMA Severe duty LV Motors
10	HSDE Model (Large motors)	NEMA Severe duty LV Motors
11	IEEE-HL Model	IEEE841 Severe duty LV Motors
12	IEEE-XL Model (Large motors)	IEEE841 Severe duty LV Motors
13	IXHHI Model	Explosion proof Severe duty LV Motors

Technical Performances

Pages	HD HYUNDAI Models	LV Motor Types
14	HES, HHI Model	Severe duty, Foot mounted
15	HSDE Model (Large motors)	Severe duty, Foot mounted
16	HES, HHI Model	Severe duty, C-Face, Foot mounted
17	HSDE Model (Large motors)	Severe duty, C-Face, Foot mounted
18	HES, HHI Model	Severe duty, D-Flange, Foot mounted
19	HES, HHI Model	Severe duty, C-Face, Footless
20	HES, HHI Model	Severe duty, D-Flange, Footless
21	HES, HHI Model	Severe duty, Vertical, C-Face, Footless
22	HES, HHI Model	Severe duty, Vertical, D-Flange, Footless
23	IEEE-HL Model	IEEE841, Foot mounted
24	IEEE-XL Model (Large motors)	IEEE841, Foot mounted
25	IEEE-HL Model	IEEE841, C-Face, Foot mounted
26	IEEE-XL Model (Large motors)	IEEE841, C-Face, Foot mounted
27	IEEE-HL Model	IEEE841, D-Flange, Foot mounted
28	IEEE-HL Model	IEEE841, C-Face, Footless
29	IEEE-HL Model	IEEE841, D-Flange, Footless
30	IEEE-HL Model	IEEE841, Vertical, C-Face, Footless
31	IEEE-HL Model	IEEE841, Vertical, D-Flange, Footless
32	IXHHI Model	Explosion proof, Foot mounted
33	IXHHI Model	Explosion proof, C-Face, Foot mounted

Dimensions & Outlines

Pages	HD HYUNDAI Models	LV Motor Types
34	HES Model	Severe duty, Foot mounted
35	HHI Model	Severe duty, Foot mounted
36	HSDE Model (Large motors)	Severe duty, Foot mounted
37	HES Model	Severe duty, C-Face, Foot mounted
38	HHI Model	Severe duty, C-Face, Foot mounted
39	HSDE Model (Large motors)	Severe duty, C-Face, Foot mounted
40	HES Model	Severe duty, D-Flange, Foot mounted
41	HHI Model	Severe duty, D-Flange, Foot mounted
42	HES Model	Severe duty, C-Face, Footless
43	HHI Model	Severe duty, C-Face, Footless
44	HES Model	Severe duty, D-Flange, Footless
45	HHI Model	Severe duty, D-Flange, Footless
46	HES Model	Severe duty, Vertical, C-Face, Footless
47	HHI Model	Severe duty, Vertical, C-Face, Footless
48	HES Model	Severe duty, Vertical, D-Flange, Footless
49	HHI Model	Severe duty, Vertical, D-Flange, Footless
50	IEEE-HL Model	IEEE841, Foot mounted
51	IEEE-XL Model (Large motors)	IEEE841, Foot mounted
52	IEEE-HL Model (Fr. 143 - 326)	IEEE841, C-Face, Foot mounted
53	IEEE-HL Model (Fr. 364 - 449)	IEEE841, C-Face, Foot mounted
54	IEEE-XL Model (Large motors)	IEEE841, C-Face, Foot mounted
55	IEEE-HL Model (Fr. 143 - 326)	IEEE841, D-Flange, Foot mounted
56	IEEE-HL Model (Fr. 364 - 449)	IEEE841, D-Flange, Foot mounted
57	IEEE-HL Model (Fr. 143 - 326)	IEEE841, C-Face, Footless
58	IEEE-HL Model (Fr. 364 - 449)	IEEE841, C-Face, Footless
59	IEEE-HL Model (Fr. 143 - 326)	IEEE841, D-Flange, Footless
60	IEEE-HL Model (Fr. 364 - 449)	IEEE841, D-Flange, Footless
61	IEEE-HL Model (Fr. 143 - 326)	IEEE841, Vertical, C-Face, Footless
62	IEEE-HL Model (Fr. 364 - 449)	IEEE841, Vertical, C-Face, Footless
63	IEEE-HL Model (Fr. 143 - 326)	IEEE841, Vertical, D-Flange, Footless
64	IEEE-HL Model (Fr. 364 - 449)	IEEE841, Vertical, D-Flange, Footless
65	IXHHI Model	Explosion proof, Foot mounted
66	IXHHI Model	Explosion proof, C-Face, Foot mounted

Products in Stock (Locations)

Pages	Offices	Warehouses
67	Houston, TX Atlanta, GA	La Porte, TX Duluth, GA Pewaukee, WI



HD HYUNDAI ELECTRIC

Proporciona a nuestros valiosos clientes motores eléctricos de **ALTA CALIDAD** disponibles en EE. UU. y Venezuela a **PRECIOS JUSTOS**.

[Catálogo de Motores](#)

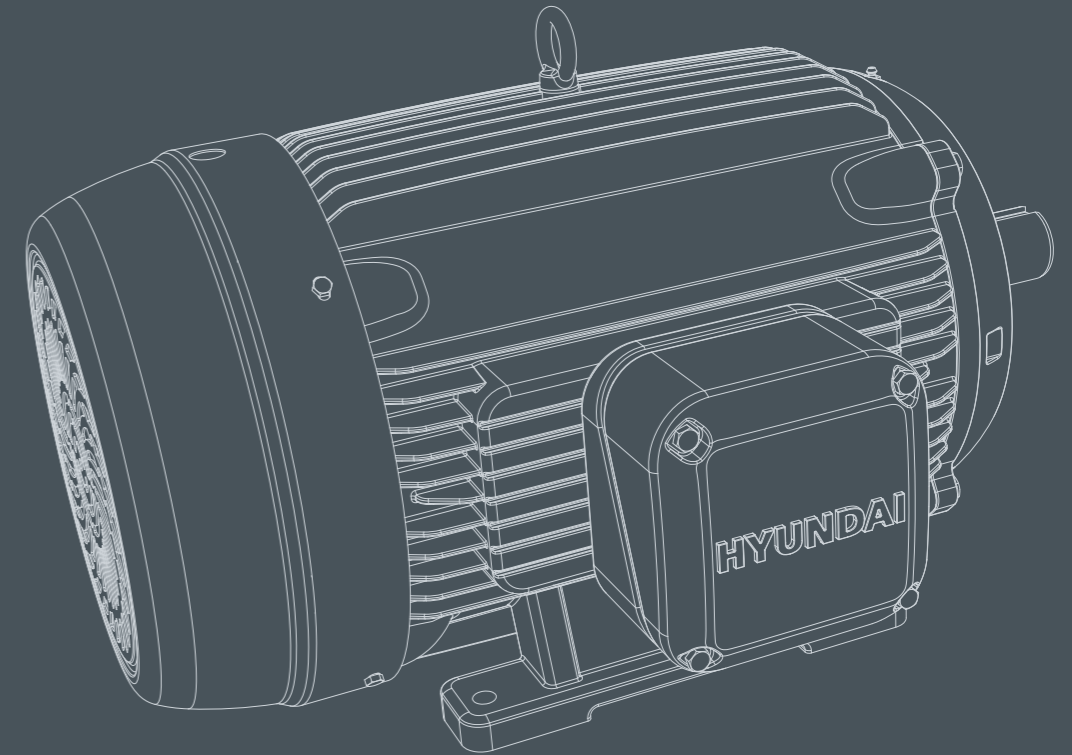

HD HYUNDAI ELECTRIC

Esencial para el Presente, Potencial para el Futuro

Como una de las filiales del Grupo HD HYUNDAI, HD Hyundai Electric es una empresa constituida a través de la escisión de la División de Negocios Eléctricos y Electrónicos de Hyundai Heavy Industry en abril de 2017. El negocio de Equipos Eléctricos fue lanzado en 1977 en la División de Negocios de Sistemas Eléctricos Pesados de Hyundai Heavy Industry; ha sido el líder en sistemas eléctricos y electrónicos generales y soluciones energéticas en Corea durante los últimos 47 años. Nuestras mentes talentosas han utilizado su creatividad y determinación como arma para convertir lo imposible en posible y ser pioneras en un nuevo paradigma tecnológico. Además, nuestras mentes talentosas han empleado su creatividad y empuje como arma para transformar lo imposible en posible y abrir camino hacia un nuevo paradigma tecnológico. Gracias al "Espíritu Hyundai", compuesto por la experiencia única, el conocimiento acumulado y la pura determinación de nuestras mentes talentosas, es con gran esperanza y alegría que lanzamos Hyundai Electric. HD Hyundai Electric está comprometida con el crecimiento del negocio de nuestros clientes y con crecer junto a ellos. Con este fin, proporcionaremos productos, soluciones y servicios de la más alta calidad para aumentar la productividad y eficiencia de nuestros clientes. Estimados clientes, acompáñennos mientras HD Hyundai Electric se convierte en el principal proveedor de soluciones energéticas del país.

Descripción General

MOTOR ELÉCTRICO

El motor eléctrico es un sistema eléctrico que convierte la energía eléctrica

en energía mecánica mediante el aprovechamiento de la energía electromagnética

para suministrar fuerza rotacional.

Los motores eléctricos accionan bombas, ventiladores, compresores y aplicaciones

en general en todas las instalaciones industriales, con energía eléctrica suministrada a través de sistemas de transformación y distribución.

La estabilidad estructural es el requisito primordial al considerar las características del producto, y la modificación de la forma aparente es limitada

debido a las dimensiones, distancias y espesores especificados.

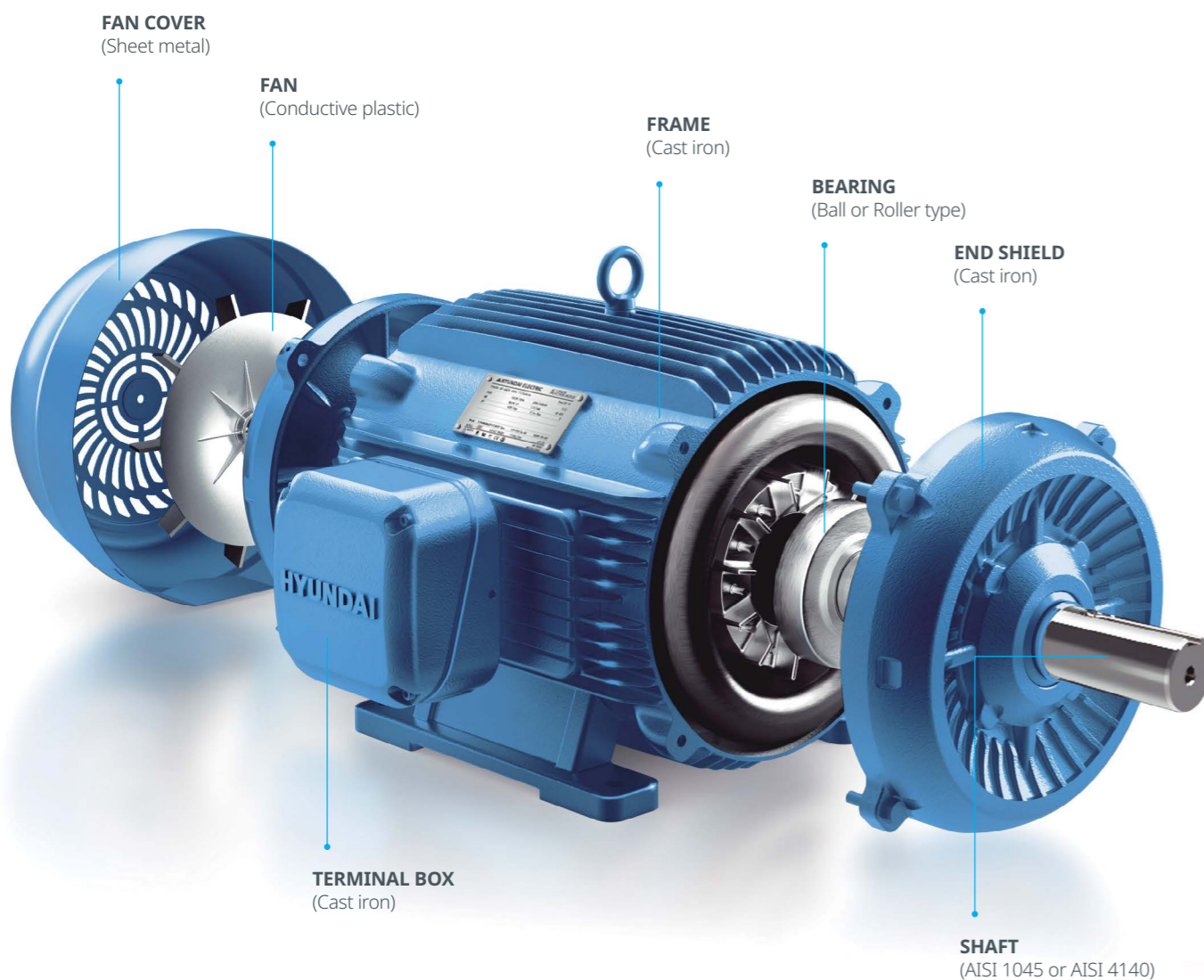

HD HYUNDAI ELECTRIC

NEMA Servicio Severo de Baja Tensión Motores de Inducción



Evoluciones de diseño continuas para Motores Eléctricos desarrolladas a través de años de experiencia, innovación y confiabilidad en la fabricación de productos de la más alta calidad.

Nuestras instalaciones de fabricación de última generación garantizan

que todos los productos cumplan con los requisitos de los clientes en cuanto a costo, entrega y calidad.



Características

- Optimización del mantenimiento del motor
- Alta eficiencia, Bajo aumento de temperatura
- Larga vida útil
- Rendimiento eléctrico y mecánico de primer nivel



Severe Duty - HSDE Model (Large motors) Premium Efficiency

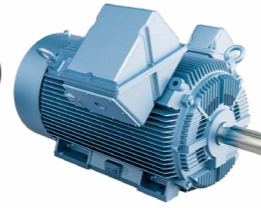

Product Electrical Features

HYUNDAI Product Type	HSDE Model	Fr. L449 - 5812
Common	Motor power (HP)	250 HP - 900 HP
	Speed (RPM)	3600, 1800 or 1200
	Frequency	60 Hz
	Altitude	3,300 ft.
	Ambient temp.	40 °C
	Enclosure	Totally Enclosed (Protection : IP55)
	Method of Cooling	IC411 (FC)
	Efficiency	NEMA Premium
	Duty	Continuous (S1)
	Design	NEMA Design B Torque
Voltage	380 V, 400 V, 415 V	Applicable at 50 Hz
	460 V	Applicable
Temp. rise	Sine Wave Power	B
	VFD Power	F
Service Factor	Sine Wave Power	1.15
	VFD Power	1.0
Inverter duty	Variable Torque 6 - 60 Hz	Applicable
	Variable Torque 3 - 60 Hz	Fr. L449 - 5011 at 50 % Load
	Constant Torque 6 - 60 Hz	Fr. L449 - 5011
	Constant Torque 30 - 60 Hz	Fr. 5812
	Constant HP	Fr. L449 - 5011

Product Mechanical Features

Mounting	Foot mount (B3)	Foot drilled hole(s)	
	C-face with Foot (B35)	Applicable	
	D-flange with Foot (B35)	Applicable	
	C-face without Foot (V1)	Applicable	
	D-flange without Foot (V1)	Applicable	
Material	Frame	Cast-iron	
	Rotor	Aluminum die casting or Centrifugal cast aluminum	
	End-shield	Cast-iron	
	Fan	Non-sparking conductive plastic fan	
Rotation	Bi-directional	Fr. L449 - 5812 at 1800, 1200 RPM	
	Uni-directional	Fr. L449 - 5812 at 3600 RPM	
	Drive end	Ball or Roller Regreasable	
Bearing	Non-Drive end	Ball or Insulation Regreasable	
	Protection	Labyrinth seal	Fr. L449 - 5812 at 3600 RPM
		V-seal	Fr. L449 - 5812 at 1800, 1200 RPM
	Inner Bearing Cap	Applied	
	Lubrication	Polyurea (Polyrex EM grease)	
Shaft	Material	AISI 1045	
		AISI 4140	
	DE threaded hole	Applied	
	DE Keyway	Opened keyway	
Terminal box	Shaft locking device	Frames with Roller bearing (To prevent Bearing brinelling)	
	Material	Cast-iron	Fr. L449 - 5011
		Fabricated Steel	Fr. 5811/12
	Mounting	F1 or F2	
Lead cable	Cable hole plug	Plastic	
	Number of lead wire(s)	6 Lead(s)	
Accessories	W.T.D (PT 100 Ohm)	2 EA / phase	
	B.T.D (PT 100 Ohm)	1 EA / Bearing	
	Space Heater	1 EA / Motor	
	Auxiliary Terminal box	2 EA / Motor	
Drain Plug	Frame	Both sides of frame bottom	
	Main Terminal Box	None	
	Grease outlet	Applied	
Tap provision	For Vib. Sensor	Applied	
	For B.T.D	Applied	
Certification	CSA	Class I, Division 2	Groups A, B, C & D *** Note (1)
		Class II, Division 2	Groups E, F & G *** Note (2)
		CSA C-390	Premium Efficiency (Up to 500 HP)
	DOE	Certi. #CC0038A	Department of Energy Efficiency
	CE	EN 60034-1	CE Declaration of Conformity
Name plate	Markings	CSA, CC(DOE), CE	
	Material	Stainless Steel AISI304	
Painting	Type	Polyurethane top coat	
	Color	Munsell 4.0PB5.4/5.5	
Common	Lifting device	Eye bolt(s)	
	Warranty	3 Years from Date of shipment	

※ Notes (1)
1) Temp. code at Sine Wave Power : T3 (Fr. L449 - 5011)
T3A (Fr. 5812)
2) Temp. code at VFD Power : T3 (Fr. L449 - 5011)

※ Notes (2)
1) Group F&G : Fr. L449 - 5011

IEEE841 - HL Model Premium Efficiency



Product Electrical Features

HYUNDAI Product Type	IEEE841 - HL Model	Fr. 143 - 449
Common	Motor power (HP)	1 HP - 250 HP
	Speed (RPM)	3600, 1800 or 1200
	Frequency	60 Hz
	Altitude	3,300 ft.
	Ambient temp.	40 °C
	Enclosure	Totally Enclosed (Protection : IP55)
	Method of Cooling	IC411 (FC)
	Efficiency	NEMA Premium
	Duty	Continuous (S1)
	Design	NEMA Design B Torque
Voltage	380 V, 400 V, 415 V	Applicable at 50 Hz
	460 V	Applicable
Temp. rise	Sine Wave Power	B
	VFD Power	F
Service Factor	Sine Wave Power	1.15
	VFD Power	1.0
Inverter duty	Variable Torque 6 - 60 Hz	Applicable
	Variable Torque 3 - 60 Hz	Applicable at 50 % Load
	Constant Torque 6 - 60 Hz	Applicable
	Constant Torque 30 - 60 Hz	Applicable
	Constant HP	CHP up to 1.5 times base speed

Product Mechanical Features

Mounting	Foot mount (B3)	Foot drilled hole(s)	
	C-face with Foot (B35)	Applicable	
	D-flange with Foot (B35)	Applicable	
	C-face without Foot (B5, V1)	Applicable	
	D-flange without Foot (B5, V1)	Applicable (Except V1 for Fr. 143 - 145)	
Material	Frame	Cast-iron	
	Rotor	Aluminum die casting	
	End-shield	Cast-iron	
	Fan	Non-sparking conductive plastic fan	
Rotation	Bi-directional	Applicable	
	Drive end	Ball or Roller Regreasable	
	Non-Drive end	Ball Regreasable	
Bearing	Protection	ProTech seal	
	Inner Bearing Cap	Applied	
	Lubrication	Polyurea (Polyrex EM grease)	
	Material	AISI 1045	
Shaft	DE threaded hole	Applied	
	DE Keyway	Opened keyway	
	Shaft locking device	Frames with Roller bearing (To prevent Bearing brinelling)	
	Terminal box	Material	Cast-iron
Lead cable	Mounting (F1 or F2)	F1 to F2 conversion available	
	Cable hole plug	Plastic	
Drain Plug	Number of lead wire(s)	3 lead(s) Fr. 143 - 326	
	Number of lead wire(s)	6 lead(s) Fr. 364 - 449	
Tap provision	Frame	Both sides of frame bottom	
	Main Terminal Box	None	
	Grease outlet	Fr. 364 - 449	
Certification	For Vib. Sensor	Fr. 364 - 449	
	For B.T.D	Fr. 364 - 449	
	CSA	Class I, Division 2	Groups A, B, C & D *** Note (1)
		Class II, Division 2	Groups E, F & G *** Note (2)
		CSA C-390	Premium Efficiency
DOE	Certi. #CC0038A	Department of Energy Efficiency	
CE	EN 60034-1	CE Declaration of Conformity	
Name plate	Markings	RU, CSA, CC(DOE), CE, IEEE45	
	Material	Stainless Steel AISI304	
Painting	Type	Epoxy Zinc with Polyurethane top coat	
	Color	Munsell 7.5BG6/1.5	
Common	Lifting device	Eye bolt(s)	
	Warranty	5 Years from Date of shipment	

※ Notes (1)
1) Temp. code at Sine Wave Power : T3C (Fr. 143 - 326)
T3B (Fr. 364 - 405)
T3A (Fr. 444 - 449)
2) Temp. code at VFD Power : T3 (Fr. 143 - 449)

※ Notes (2)
1) Group E : Fr. 143 - 326
2) Group F&G : Fr. 143 - 449

U.S Standard
LV NEMA Motor

IEEE841 - XL Model (Large motor) Premium Efficiency



U.S Standard
LV NEMA Motor

Explosion proof Premium Efficiency



Product Electrical Features

HYUNDAI Product Type	IEEE841 - XL Model	Fr. L449 - 5812
Common	Motor power (HP)	250 HP - 900 HP
	Speed (RPM)	3600, 1800 or 1200
	Frequency	60 Hz
	Altitude	3,300 ft.
	Ambient temp.	40 °C
	Enclosure	Totally Enclosed (Protection : IP55)
	Method of Cooling	IC411 (FC)
	Efficiency	NEMA Premium
	Duty	Continuous (S1)
	Design	NEMA Design B Torque
	Insulation Class	F (Impregnation Resin & Magnet wire : Class H) Inverter duty, Exceeds NEMA MG-1 Part 31
Voltage	380 V, 400 V, 415 V	Applicable at 50 Hz
	460 V	Applicable
	575 V	Applicable
Temp. rise	Sine Wave Power	B
	VFD Power	F
Service Factor	Sine Wave Power	1.15
	VFD Power	1.0
Inverter duty	Variable Torque 6 - 60 Hz	Applicable
	Variable Torque 3 - 60 Hz	Fr. L449 - 5011 at 50 % Load
	Constant Torque 6 - 60 Hz	Fr. L449 - 5011
	Constant Torque 30 - 60 Hz	Fr. 5812
	Constant HP	Fr. L449 - 5011

Product Mechanical Features

Mounting	Foot mount (B3)	Foot drilled hole(s)	
	C-face with Foot (B35)	Applicable	
	D-flange with Foot (B35)	Applicable	
Material	C-face without Foot (V1)	Applicable	
	D-flange without Foot (V1)	Applicable	
	Frame	Cast-iron	
	Rotor	Aluminum die casting or Centrifugal cast aluminum	
	End-shield	Cast-iron	
Rotation	Fan	Non-sparking conductive plastic fan	
	Fan cover	Fabricated steel	
	Bi-directional	Fr. L449 - 5812 at 1800, 1200 RPM	
	Uni-directional	Fr. L449 - 5812 at 3600 RPM	
Bearing	Drive end	Ball or Roller Regreasable	
	Non-Drive end	Ball or Insulation Regreasable	
	Protection	Labyrinth seal ProTech seal	
	Inner Bearing Cap	Applied	
Shaft	Lubrication	Polyurea (Polyrex EM grease)	
	Material	AISI 1045 AISI 4140	
	DE threaded hole	Applied	
	DE Keyway	Opened keyway	
Terminal box	Shaft locking device	Frames with Roller bearing (To prevent Bearing brinelling)	
	Material	Cast-iron Fabricated Steel	
	Mounting	Cast-iron Fabricated Steel	
Lead cable	Cable hole plug	Plastic	
	Number of lead wire(s)	6 Lead(s)	
Accessories	W.T.D (PT 100 Ohm)	2 EA / phase	
	B.T.D (PT 100 Ohm)	1 EA / Bearing	
	Space Heater	1 EA / Motor	
	Auxiliary Terminal box	2 EA / Motor	
Drain Plug	Frame	Both sides of frame bottom	
	Main Terminal Box	None	
	Grease outlet	Applied	
Tap provision	For Vib. Sensor	Applied	
	For B.T.D	Applied	
Certification	CSA	Class I, Division 2	Groups A, B, C & D *** Note (1)
		Class II, Division 2	Groups E, F & G *** Note (2)
	DOE	CSA C-390	Premium Efficiency (Up to 500 HP)
	CE	Certi. #CC0038A	Department of Energy Efficiency
	IEEE45	EN 60034-1	CE Declaration of Conformity
Name plate	Markings	ABS Product Type Approval	Marine Duty (Up to 600 HP / Fr. L449 - 5011)
	Material	CSA, CC(DOE), CE	Stainless Steel AISI304
Painting	Type	Epoxy Zinc with Polyurethane top coat	
	Color	Munsell 7.5BG6/1.5	
Common	Lifting device	Eye bolt(s)	
	Warranty	5 Years from Date of shipment	

※ Notes (1)
1) Temp. code at Sine Wave Power : T3 (Fr. L449 - 5011)
T3A (Fr. 5812)
2) Temp. code at VFD Power : T3 (Fr. L449 - 5011)

※ Notes (2)
1) Group F&G : Fr. L449 - 5011

Product Electrical Features

HYUNDAI Product Type	IXHHI	Fr. 143 - 449
Common	Motor power (HP)	1 HP - 250 HP
	Speed (RPM)	3600, 1800 or 1200
	Frequency	60 Hz
	Altitude	3,300 ft.
	Ambient temp.	40 °C
	Enclosure I Protection	Totally Enclosed (Protection : IP55)
	Method of Cooling	IC411 (FC)
	Efficiency	NEMA Premium
	Duty	Continuous (S1)
	Design	NEMA Design B Torque
	Insulation Class	F (Impregnation Resin & Magnet wire : Class H) Inverter duty, Exceeds NEMA MG-1 Part 31
Voltage	230/460 V	1 HP - 125 HP
	380 V, 400 V, 415 V	Applicable at 50 Hz
	460 V	150 HP - 250 HP
Temp. rise	575 V	Applicable
	Sine Wave Power	B
Service Factor	VFD Power	F
	Sine Wave Power	1.15
Inverter duty	VFD Power	1.0
	Temp. rise F & Non-hazardous	1.25 (Up to Fr. 143 - 365)
Inverter duty	Variable Torque 6 - 60 Hz	Applicable
	Variable Torque 3 - 60 Hz	Applicable at 50 % Load
	Constant Torque 10.5 - 60 Hz	Fr. 143 - 215
	Constant Torque 15 - 60 Hz	Fr. 254 - 449
	Constant Torque 6 - 60 Hz	Fr. 143 - 449 at 1 hour duty
	Constant HP	CHP up to 1.5 times base speed

Product Mechanical Features

Mounting	Foot mount (B3)	Foot drilled hole(s)	
	C-face with Foot (B35)	Fr. 143 - 326	
	C-face without Foot (B5, V1)	Fr. 143 - 326	
Material	Frame	Cast-iron	
	Rotor	Aluminum die casting	
	End-shield	Cast-iron	
	Fan	Non-sparking conductive plastic fan	
	Fan cover	Steel	
Rotation	Bi-directional	Applicable	
	Drive end	Ball or Roller Regreasable (Fr. 254 - 449)	
Bearing	Non-Drive end	Ball Regreasable (Fr. 254 - 449)	
	Protection	V-seal Labyrinth	
	Inner Bearing Cap	Applied	
	Lubrication	Polyurea (Polyrex EM grease)	
Shaft	Material	AISI 1045	
	DE threaded hole	Applied	
	DE Keyway	Opened keyway	
	Shaft locking device	Frames with Roller bearing (To prevent Bearing brinelling)	
Terminal box	Material	Cast-iron	
	Mounting (F1 or F2)	F1 to F2 conversion available	
Lead cable	Cable hole plug	Plastic	
	Number of lead wire(s)	9 lead(s) Fr. 143 - 215	
	Number of lead wire(s)	12 lead(s) Fr. 254 - 445 (~125HP)	
Accessories	Number of lead wire(s)	6 lead(s) Fr. 445 - 449 (150HP~)	
	W.T.D (Thermostat)	1 EA / phase (145 °C)	
Drain Plug	Frame	Both sides of frame bottom	
	Main Terminal Box	None	
	Grease outlet	Fr. 254 - 449	
	For Vib. Sensor	Fr. 364 - 449	
Tap provision	For B.T.D	Fr. 364 - 449	
	UL	Class I, Division 1	Group C & D *** Note (1)
		Class II, Division 1	Group F & G *** Note (2)
	CSA	CSA C-390	Premium Efficiency
	DOE	Certi. #CC0038A	Department of Energy Efficiency
CE	EN 60034-1	CE Declaration of Conformity	
Name plate	Markings	UL LISTED, CSA, CC(DOE), CE	
	Material	Stainless Steel AISI304	
Painting	Type	Polyurethane top coat	
	Color	Munsell 4.0PB5.4/5.5	
Common	Lifting device	Eye bolt(s)	
	Warranty	3 Years from Date of shipment	

※ Notes (1)
1) Temperature code : T2C (Fr. 143 - 215)
T2D (Fr. 254 - 286)
T3 (Fr. 354 - 449)
T4 (Fr. 143 - 449) with Thermostat

※ Notes (2)
1) Temperature code : T3B (Fr. 143 - 326)

HES, HHI Model - Severe duty, Premium Efficiency Three phase, TEFC, Foot mounted



Features

- Insulation Class F, Temperature rise B, 40 °C ambient
- 230/460 V (~125 HP), 460 V (150 HP~)
- NEMA Design B
- Cast Iron construction, Direct-on-line & Inverter duty
- IP55, Diagonally split, Gasketed terminal box
- Tap provision for Vib. sensor & Bearing Temp. Detector (Except Vib. sensor & Bearing Temp. Detector)

Foot Mounted

Catalog Number	HP	Frame Number	RPM (Speed)	Volts (V)	FL EFF. (%)	FL PF	FL AMPS (A)	Locked Rotor AMPS (%)	Torque			Sound pressure Level dB(A)	Approx. Weight (LB.)
									Rated (LB.FT)	Locked Rotor %FLT	Break down %FLT		
HES1-36-143T	1	143T	3490	230/460	77.0	0.82	2.98/1.49	830	1.51	200	270	69	55
HES1-18-143T	1	143T	1755	230/460	85.5	0.70	3.15/1.57	930	3.01	280	310	56	55
HES1-12-145T	1	145T	1155	230/460	82.5	0.63	3.62/1.81	800	4.57	180	275	55	55
HES1.5-36-143T	1.5	143T	3485	230/460	84.0	0.84	3.91/1.96	1000	2.22	185	260	69	55
HES1.5-18-145T	1.5	145T	1750	230/460	86.5	0.72	4.43/2.22	900	4.43	260	290	56	55
HES1.5-12-182T	1.5	182T	1175	230/460	87.5	0.61	5.17/2.59	770	6.60	190	270	55	105
HES2-36-145T	2	145T	3480	230/460	85.5	0.85	5.18/2.59	950	3.04	180	250	69	55
HES2-18-145T	2	145T	1745	230/460	86.5	0.73	5.96/2.98	830	6.06	245	280	56	55
HES2-12-184T	2	184T	1175	230/460	88.5	0.68	6.26/3.13	790	8.99	180	260	55	105
HES3-36-182T	3	182T	3520	230/460	86.5	0.85	7.51/3.76	760	4.40	190	260	72	105
HES3-18-182T	3	182T	1770	230/460	89.5	0.79	7.81/3.91	930	8.76	220	280	60	105
HES3-12-213T	3	213T	1185	230/460	89.5	0.67	9.21/4.6	770	13.08	180	250	57	150
HES5-36-184T	5	184T	3515	230/460	88.5	0.86	12.2/6.1	800	7.42	190	260	72	105
HES5-18-184T	5	184T	1760	230/460	89.5	0.80	12.97/6.49	840	14.81	210	260	60	105
HES5-12-215T	5	215T	1180	230/460	89.5	0.68	15.26/7.63	680	22.09	170	220	57	175
HES7.5-36-213T	7.5	213T	3530	230/460	89.5	0.85	18.15/9.07	700	10.98	160	260	73	150
HES7.5-18-213T	7.5	213T	1775	230/460	91.7	0.77	19.55/9.78	940	21.83	190	250	62	150
HES7.5-12-254T	7.5	254T	1175	230/460	91.0	0.75	20.23/10.11	640	32.98	170	250	64	240
HES10-36-215T	10	215T	3525	230/460	90.2	0.86	24.27/12.13	680	14.99	160	260	73	175
HES10-18-215T	10	215T	1770	230/460	91.7	0.79	25.99/12.99	750	29.85	180	240	62	175
HES10-12-256T	10	256T	1175	230/460	91.0	0.75	27.58/13.79	680	44.97	170	250	64	290
HES15-36-254T	15	254T	3550	230/460	91.0	0.88	34.5/17.2	710	21.83	150	250	77	240
HES15-18-254T	15	254T	1775	230/460	92.4	0.82	36.4/18.2	750	43.66	200	240	70	240
HES15-12-284T	15	284T	1175	230/460	91.7	0.77	39.1/19.6	600	65.95	155	240	65	360
HES20-36-256T	20	256T	3550	230/460	91.0	0.89	46.5/23.2	740	29.77	150	250	77	290
HES20-18-256T	20	256T	1775	230/460	93.0	0.82	49.7/24.8	800	59.53	200	240	70	290
HES20-12-286T	20	286T	1175	230/460	91.7	0.77	53.3/26.7	650	89.94	150	230	65	410
HES25-36-284TS	25	284TS	3560	230/460	91.7	0.89	56.9/28.5	670	36.61	160	230	80	360
HES25-18-284T	25	284T	1775	230/460	93.6	0.81	61.3/30.6	790	73.43	170	220	72	360
HES25-12-324T	25	324T	1175	230/460	93.0	0.80	62.4/31.2	720	110.92	170	210	68	550
HES30-36-286TS	30	286TS	3560	230/460	91.7	0.89	67.7/33.8	685	43.54	160	230	80	410
HES30-18-286T	30	286T	1775	230/460	93.6	0.81	72.8/36.4	740	87.32	170	220	72	410
HES30-12-326T	30	326T	1175	230/460	93.0	0.80	74.2/37.1	830	131.91	170	210	68	560
HES40-36-324TS	40	324TS	3560	230/460	92.4	0.92	89.1/44.5	850	59.37	150	230	82	550
HES40-18-324T	40	324T	1780	230/460	94.1	0.82	97.6/48.8	850	118.74	170	220	74	550
HHI40-12-364T	40	364T	1185	230/460	94.1	0.82	97.6/48.8	680	178.36	150	220	73	780
HES50-36-326TS	50	326TS	3560	230/460	93.0	0.92	109.1/54.6	850	73.22	150	230	82	560
HES50-18-326T	50	326T	1780	230/460	94.5	0.84	117/58.5	830	146.44	170	220	74	560
HHI50-12-365T	50	365T	1185	230/460	94.1	0.82	120.4/60.2	680	219.98	150	220	73	820
HHI60-36-364TS	60	364TS	3570	230/460	94.1	0.92	131.2/65.6	680	88.81	140	220	82	780
HHI60-18-364T	60	364T	1780	230/460	95.0	0.85	139.9/69.9	670	178.11	150	220	82	780
HHI60-12-404T	60	404T	1185	230/460	94.5	0.84	142.3/71.2	670	267.54	140	220	75	1120
HHI75-36-365TS	75	365TS	3570	230/460	94.5	0.92	159.7/79.8	680	108.54	140	220	82	820
HHI75-18-365T	75	365T	1780	230/460	95.4	0.85	170.3/85.1	690	217.69	150	220	82	820
HHI75-12-405T	75	405T	1185	230/460	94.5	0.84	173.9/87	680	326.99	140	220	75	1120
HHI100-36-405TS	100	405TS	3570	230/460	94.5	0.91	220.1/110.1	700	148.01	120	220	87	1120
HHI100-18-405T	100	405T	1780	230/460	95.4	0.87	228.1/114.1	650	296.85	140	220	82	1120
HHI100-12-444T	100	444T	1185	230/460	95	0.85	233.1/116.6	680	445.90	140	220	80	1530
HHI125-36-444TS	125	444TS	3570	230/460	95	0.90	278.9/139.5	700	187.48	120	220	92	1610
HHI125-18-444T	125	444T	1785	230/460	95.4	0.88	284.1/142	700	374.96	140	220	85	1530
HHI125-12-445T	125	445T	1185	230/460	95	0.85	295.3/147.7	675	564.81	140	220	80	1640
HHI150-36-445TS	150	445TS	3570	460	95	0.90	323/161.5	700	217.08	120	220	92	1770
HHI150-18-445T	150	445T	1785	460	95.8	0.88	327.5/163.8	700	434.16	140	220	85	1640
HHI150-12-447T	150	447T	1185	460	95.8	0.85	339.1/169.5	680	653.99	140	220	80	1860
HHI200-36-447TS	200	447TS	3570	460	95.4	0.90	438.5/219.3	700	296.02	120	220	92	1900
HHI200-18-447T	200	447T	1785	460	96.2	0.88	444.8/222.4	700	592.04	140	220	85	1860
HHI200-12-449T	200	449T	1185	460	95.8	0.85	462.4/231.2	680	891.80	140	220	80	2430
HHI250-36-449TS	250	449TS	3570	460	95.8	0.90	553.2/276.6	700	374.96	120	220	92	2430
HHI250-18-449T	250	449T	1785	460	96.2	0.88	563.4/281.7	700	749.91	140	220	85	2430

* For Electrical performances of 575 V Motor(s), please inquire with us, HD Hyundai Electric America.

HSDE Model - Severe duty, Large motor Three phase, TEFC, Foot mounted

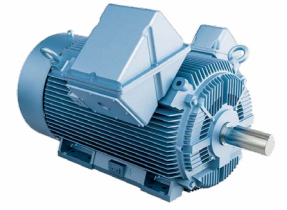

Features

- Insulation Class F, Temperature rise B or F, 40 °C ambient
- Cast Iron construction, 460 V, Direct-on-line & Inverter duty
- WTD PT 100 Ohm 2 EA/Phase
- BTD PT 100 Ohm 1 EA/Bearing
- Heater 1 EA/Motor
- Auxiliary Terminal Box 2EA/Motor
- Tap provision for Vib. sensor (Except Vib. sensor)

Catalog Number Suffix

- BB : Ball Bearing
- IB : Insulation Bearing on N-DE
- 2IB : Insulation Bearing on DE & N-DE
- BR : Bearing RTDs (1 EA/Bearing) with Aux. T/box
- SR : Stator RTDs (2 EA/Ph.) with Aux. T/box
- SH : Space Heater (1 EA/Motor) with Aux. T/box
- SP : Spare part (Spare cooling fan)
- LL : Long lead cable
- F : Temp. rise F (Standard Temp. rise B at Ambient temp. 40 °C)

Foot Mounted

Catalog Number	HP	Frame Number	RPM (Speed)	Volts (V)	FL EFF. (%)	FL PF	FL AMPS (A)	Locked Rotor AMPS (%)	Torque			Sound pressure Level dB(A)	Approx. Weight (LB.)
									Rated (LB.FT)	Locked Rotor %FLT	Break down %FLT		
HSDE250-12-L449T-IBBRSRSH	250	L449T	1185	460	95.8	0.84	296.3	680	1129.6	135	200	80	2890
HSDE300-36-L449TS-IBBRSRSHSP	300	L449TS	3570	460	95.8	0.90	327.5	700	444.0	130	225	87	2890
HSDE300-18-L449T-IBBRSRSH	300	L449T	1785	460	96.2	0.88	333.6	710	888.1	135	225	85	2890
HSDE300-12-L449T-IBBRSRSH	300	L449T	1185	460	95.8	0.84	350.9	675	1337.7	135	220	80	3320
HSDE350-36-L449TS-IBBRSRSHSP	350	L449TS	3570	460	95.8	0.90	378.5	700	513.1	130	225	87	3090
HSDE350-18-L449T-IBBRSRSH	350	L449T	1785	460	96.2	0.88	385.5	715	1026.2	135	225	85	3090
HSDE350-12-L449T-IBBRSRSH	350	L449T	1185	460	95.8	0.84	407.1	650	1551.7	120	200	80	3380
HSDE400-36-L449TS-IBBRSRSHSP	400	L449TS	3570	460	95.8	0.90	436.7	680	592.0	145	240	87	3820
HSDE400-18-L449T-IBBRSRSH	400	L449T	1785	460	96.2	0.88	444.8	710	1184.1	135	225	85	3620
HSDE400-12-5009-IBBRSRSH	400	5009	1185	460	95.8	0.84	467.9	680	1783.6	135	220	84	3970
HSDE450-36-5009S-IBBRSRSHSP	450	5009S	3570	460	95.8	0.90	487.7	725	661.1	130	230	87	3860
HSDE450-18-5009-IBBRSRSH	450	5009	1785	460	96.2	0.89	491.1	720	1322.2	135	230	85	3970
HSDE450-12-5009-IBBRSRSH	450	5009	1185	460	95.8	0.84	522.5	675	1991.7	135	220	84	4030
HSDE500-36-5010S-IBBRSRSHSP	500	5010S	3570	460	95.8	0.90	545.9	725	740.0	145	240	87	4800
HSDE500-18-5010-IBBRSRSH	500	5010	1785	460	96.2	0.89	549.7	720	1480.1	135	220	85	4820
HSDE500-12-5011-IBBRSRSH	500	5010	1185	460	95.8	0.84	584.9	675	2229.5	135	220	84	4850
HSDE600-18-5011-IBBRSRSH	600	5011	1785	460	96.2	0.89	659.7	720	1776.1	135	230	85	4940
HSDE600-36-5812S-IBBRSRSHSP	600	5812S</											

U.S Standard
LV NEMA Motor

HES, HHI Model - Severe duty, Premium Efficiency Three phase, TEFC, C-Face, Foot mounted



Features

- Insulation Class F, Temperature rise B, 40 °C ambient
- 230/460 V (~ 125 HP), 460 V (150 HP ~)
- Cast Iron construction, Direct-on-line & Inverter duty
- IP55, Diagonally split, Gasketed terminal box, Fully rotatable at 90 increments
- Tap provision for Vib. sensor & Bearing Temp. Detector (Except Vib. sensor & Bearing Temp. Detector)

C-Face, Foot Mounted

Catalog Number	HP	Frame Number	RPM (Speed)	Volts (V)	FL EFF. (%)	FL PF	FL AMPS (A)	Locked Rotor AMPS (%)	Torque			Sound pressure Level dB(A)	Approx. Weight (LB.)
									Rated (LB.FT)	Locked Rotor %FLT	Break down %FLT		
HES1-36-143TC	1	143TC	3490	230/460	77.0	0.82	2.98/1.49	830	1.51	200	270	69	55
HES1-18-143TC	1	143TC	1755	230/460	85.5	0.70	3.15/1.57	930	3.01	280	310	56	55
HES1-12-145TC	1	145TC	1155	230/460	82.5	0.63	3.62/1.81	800	4.57	180	275	55	55
HES1.5-36-143TC	1.5	143TC	3485	230/460	84.0	0.84	3.91/1.96	1000	2.22	185	260	69	55
HES1.5-18-145TC	1.5	145TC	1750	230/460	86.5	0.72	4.43/2.22	900	4.43	260	290	56	55
HES1.5-12-182TC	1.5	182TC	1175	230/460	87.5	0.61	5.17/2.59	770	6.60	190	270	55	105
HES2-36-145TC	2	145TC	3480	230/460	85.5	0.85	5.18/2.59	950	3.04	180	250	69	55
HES2-18-145TC	2	145TC	1745	230/460	86.5	0.73	5.96/2.98	830	6.06	245	280	56	55
HES2-12-184TC	2	184TC	1175	230/460	88.5	0.68	6.26/3.13	790	8.99	180	260	55	105
HES3-36-182TC	3	182TC	3520	230/460	86.5	0.85	7.51/3.76	760	4.40	190	260	72	105
HES3-18-182TC	3	182TC	1770	230/460	89.5	0.79	7.81/3.91	930	8.76	220	280	60	105
HES3-12-213TC	3	213TC	1185	230/460	89.5	0.67	9.21/4.6	770	13.08	180	250	57	150
HES5-36-184TC	5	184TC	3515	230/460	88.5	0.86	12.2/6.1	800	7.42	190	260	72	105
HES5-18-184TC	5	184TC	1760	230/460	89.5	0.80	12.97/6.49	840	14.81	210	260	60	105
HES5-12-215TC	5	215TC	1180	230/460	89.5	0.68	15.26/7.63	680	22.09	170	220	57	175
HES7.5-36-213TC	7.5	213TC	3530	230/460	89.5	0.85	18.15/9.07	700	10.98	160	260	73	150
HES7.5-18-213TC	7.5	213TC	1775	230/460	91.7	0.77	19.55/9.78	940	21.83	190	250	62	150
HES7.5-12-254TC	7.5	254TC	1175	230/460	91.0	0.75	20.23/10.11	640	32.98	170	250	64	240
HES10-36-215TC	10	215TC	3525	230/460	90.2	0.86	24.27/12.13	680	14.99	160	260	73	175
HES10-18-215TC	10	215TC	1770	230/460	91.7	0.79	25.99/12.99	750	29.85	180	240	62	175
HES10-12-256TC	10	256TC	1175	230/460	91.0	0.75	27.58/13.79	680	44.97	170	250	64	290
HES15-36-254TC	15	254TC	3550	230/460	91.0	0.88	34.5/17.2	710	21.83	150	250	77	240
HES15-18-254TC	15	254TC	1775	230/460	92.4	0.82	36.4/18.2	750	43.66	200	240	70	240
HES15-12-284TC	15	284TC	1175	230/460	91.7	0.77	39.1/19.6	600	65.95	155	240	65	360
HES20-36-256TC	20	256TC	3550	230/460	91.0	0.89	46.5/23.2	740	29.77	150	250	77	290
HES20-18-256TC	20	256TC	1775	230/460	93.0	0.82	49.7/24.8	800	59.53	200	240	70	290
HES20-12-286TC	20	286TC	1175	230/460	91.7	0.77	53.3/26.7	650	89.94	150	230	65	410
HES25-36-284TC	25	284TC	3560	230/460	91.7	0.89	56.9/28.5	670	36.61	160	230	80	360
HES25-18-284TC	25	284TC	1775	230/460	93.6	0.81	61.3/30.6	790	73.43	170	220	72	360
HES25-12-324TC	25	324TC	1175	230/460	93.0	0.80	62.4/31.2	720	110.92	170	210	68	550
HES30-36-286TC	30	286TC	3560	230/460	91.7	0.89	67.7/33.8	685	43.54	160	230	80	410
HES30-18-286TC	30	286TC	1775	230/460	93.6	0.81	72.8/36.4	740	87.32	170	220	72	410
HES30-12-326TC	30	326TC	1175	230/460	93.0	0.80	74.2/37.1	830	131.91	170	210	68	560
HES40-36-324TC	40	324TC	3560	230/460	92.4	0.92	89.1/44.5	850	59.37	150	230	82	550
HES40-18-324TC	40	324TC	1780	230/460	94.1	0.82	97.6/48.8	850	118.74	170	220	74	550
HHI40-12-364TC	40	364TC	1185	230/460	94.1	0.82	97.6/48.8	680	178.36	150	220	73	780
HES50-36-326TC	50	326TC	3560	230/460	93.0	0.92	109.1/54.6	850	73.22	150	230	82	560
HES50-18-326TC	50	326TC	1780	230/460	94.5	0.84	117/58.5	830	146.44	170	220	74	560
HHI50-12-365TC	50	365TC	1185	230/460	94.1	0.82	120.4/60.2	680	219.98	150	220	73	820
HHI60-36-364TC	60	364TC	3570	230/460	94.1	0.92	131.2/65.6	680	88.81	140	220	82	780
HHI60-18-364TC	60	364TC	1780	230/460	95.0	0.85	139.9/69.9	670	178.11	150	220	82	780
HHI60-12-404TC	60	404TC	1185	230/460	94.5	0.84	142.3/71.2	670	267.54	140	220	75	1120
HHI75-36-365TC	75	365TC	3570	230/460	94.5	0.92	159.7/79.8	680	108.54	140	220	82	820
HHI75-12-405TC	75	405TC	1185	230/460	94.5	0.84	173.9/87	680	326.99	140	220	75	1120
HHI100-36-405TC	100	405TC	3570	230/460	94.5	0.91	220.1/110.1	700	148.01	120	220	87	1120
HHI100-18-405TC	100	405TC	1780	230/460	95.4	0.87	228.1/114.1	650	296.85	140	220	82	1120
HHI100-12-444TC	100	444TC	1185	230/460	95	0.85	233.1/116.6	680	445.90	140	220	80	1530
HHI125-36-444TC	125	444TC	3570	230/460	95	0.90	278.9/139.5	700	187.48	120	220	92	1610
HHI125-18-444TC	125	444TC	1785	230/460	95.4	0.88	284.1/142	700	374.96	140	220	85	1530
HHI125-12-445TC	125	445TC	1185	230/460	95	0.85	295.3/147.7	675	564.81	140	220	80	1640
HHI150-36-445TC	150	445TC	3570	460	95	0.90	323/161.5	700	217.08	120	220	92	1770
HHI150-18-445TC	150	445TC	1785	460	95.8	0.88	327.5/163.8	700	434.16	140	220	85	1640
HHI150-12-447TC	150	447TC	1185	460	95.8	0.85	339.1/169.5	680	653.99	140	220	80	1860
HHI200-36-447TC	200	447TC	3570	460	95.4	0.90	438.5/219.3	700	296.02	120	220	92	1900
HHI200-18-447TC	200	447TC	1785	460	96.2	0.88	444.8/222.4	700	592.04	140	220	85	1860
HHI200-12-449TC	200	449TC	1185	460	95.8	0.85	462.4/231.2	680	891.80	140	220	80	2430
HHI250-36-449TC	250	449TC	3570	460	95.8	0.90	553.2/276.6	700	374.96	120	220	92	2430
HHI250-18-449TC	250	449TC	1785	460	96.2	0.88	563.4/281.7	700	749.91	140	220	85	2430

* For Electrical performances of 575 V Motor(s), please inquire with us, HD Hyundai Electric America.

U.S Standard
LV NEMA Motor

HSDE Model - Severe duty, Large motor Three phase, TEFC, C-Face, Foot mounted

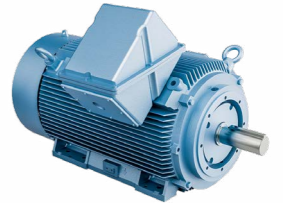

Features

- Insulation Class F, Temperature rise B or F, 40 °C ambient
- Cast Iron construction, 460 V, Direct-on-line & Inverter duty
- WTD PT 100 Ohm 2 EA/Phase
- BTD PT 100 Ohm 1 EA/Bearing
- Heater 1 EA/Motor
- Auxiliary Terminal Box 2 EA/Motor
- Tap provision for Vib. sensor (Except Vib. sensor)

Catalog Number Suffix

- BB : Ball Bearing
- IB : Insulation Bearing on N-DE
- 2IB : Insulation Bearing on DE & N-DE
- BR : Bearing RTDs (1 EA/Bearing) with Aux. T/box
- SR : Stator RTDs (2 EA/Ph.) with Aux. T/box
- SH : Space Heater (1 EA/Motor) with Aux. T/box
- SP : Spare part (Spare cooling fan)
- LL : Long lead cable
- F : Temp. rise F (Standard Temp. rise B at Ambient temp. 40 °C)

C-Face, Foot Mounted

Catalog Number	HP	Frame Number	RPM (Speed)	Volts (V)	FL EFF. (%)	FL PF	FL AMPS (A)	Locked Rotor AMPS (%)	Torque			Sound pressure Level dB(A)	Approx. Weight (LB.)
									Rated (LB.FT)	Locked Rotor %FLT	Break down %FLT		
HSDE250-12-L449TC-IBBRSRSH	250	L449TC	1185	460	95.8	0.84	296.3	680	1129.6	135	200	80	2890
HSDE300-36-L449TSC-IBBRSRSHSP	300	L449TSC	3570	460	95.8	0.90	327.5	700	444.0	130	225	87	2890
HSDE300-18-L449TC-IBBRSRSH	300	L449TC	1785	460	96.2	0.88	333.6	710	888.1	135	225	85	2890
HSDE300-12-L449TC-IBBRSRSH	300	L449TC	1185	460	95.8	0.84	350.9	675	1337.7	135	220	80	3320
HSDE350-36-L449TSC-IBBRSRSHSP	350	L449TSC	3570	460	95.8	0.90	378.5	700	513.1	130	225	87	3090
HSDE350-18-L449TC-IBBRSRSH	350	L449TC	1785	460	96.2	0.88	385.5	715	1026.2	135	225	85	3090
HSDE350-12-L449TC-IBBRSRSH	350	L449TC	1185	460	95.8	0.84	407.1	650	1551.7	120	200	80	3380
HSDE400-36-L449TSC-IBBRSRSHSP	400	L449TSC	3570	460	95.8	0.90	436.7	680	592.0	145	240	87	3820
HSDE400-18-L449TC-IBBRSRSH	400	L449TC	1785	460	96.2	0.88	444.8	710	1184.1	135	225	85	3620
HSDE400-12-5009C-IBBRSRSH	400	5009C	1185	460	95.8	0.84	467.9	680	1783.6	135	220	84	3970
HSDE450-36-5009C-IBBRSRSHSP	450	5009C	3570	460	95.8	0.90	487.7	725	661.1	130	230	87	3860
HSDE450-18-5009C-IBBRSRSH	450	5009C	1785	460	96.2	0.89	491.1	720	1322.2	135	230	85	3970
HSDE450-12-5009C-IBBRSRSH	450	5009C	1185	460	95.8	0.84	522.5	675	1991.7	135	220	84	4030
HSDE500-36-5010C-IBBRSRSHSP	500	5010C	3570	460	95.8	0.90	545.9	725	740.0	145	240	87	4800
HSDE500-18-5010C-IBBRSRSH	500	5010C	1785	460	96.2	0.89	549.7	720	1480.1	135	220	85	4820
HSDE500-12-5011C-IBBRSRSH	500	5010C	1185	460	95.8	0.84	584.9	675	2229.5	135	220	84	4850
HSDE600-18-5011C-IBBRSRSH	600	5011C	1785	460	96.2	0.89	659.7	720	1776.1	135	230	85	4940
HSDE600-36-5812C-IBBRSRSHSP	600	5812C	3570	460	95.8	0.89	662.4	670	888.1	150	250	89	6730
HSDE600-12-58													

HES, HHI Model - Severe duty, Premium Efficiency Three phase, TEFC, D-Flange, Foot mounted



Features

- Insulation Class F, Temperature rise B, 40 °C ambient
- 230/460 V (~ 125 HP), 460 V (150 HP ~)
- Cast Iron construction, Direct-on-line & Inverter duty
- IP55, Diagonally split, Gasketed terminal box, Fully rotatable at 90 increments
- Tap provision for Vib. sensor & Bearing Temp. Detector (Except Vib. sensor & Bearing Temp. Detector)

D-Flange, Foot Mounted

Catalog Number	HP	Frame Number	RPM (Speed)	Volts (V)	FL EFF. (%)	FL PF	FL AMPS (A)	Locked Rotor AMPS (%)	Torque			Sound pressure Level dB(A)	Approx. Weight (LB.)
									Rated (LB.FT)	Locked Rotor %FLT	Break down %FLT		
HES1-36-143TD	1	143TD	3490	230/460	77.0	0.82	2.98/1.49	830	1.51	200	270	69	55
HES1-18-143TD	1	143TD	1755	230/460	85.5	0.70	3.15/1.57	930	3.01	280	310	56	55
HES1-12-145TD	1	145TD	1155	230/460	82.5	0.63	3.62/1.81	800	4.57	180	275	55	55
HES1.5-36-143TD	1.5	143TD	3485	230/460	84.0	0.84	3.91/1.96	1000	2.22	185	260	69	55
HES1.5-18-145TD	1.5	145TD	1750	230/460	86.5	0.72	4.43/2.22	900	4.43	260	290	56	55
HES1.5-12-182TD	1.5	182TD	1175	230/460	87.5	0.61	5.17/2.59	770	6.60	190	270	55	105
HES2-36-145TD	2	145TD	3480	230/460	85.5	0.85	5.18/2.59	950	3.04	180	250	69	55
HES2-18-145TD	2	145TD	1745	230/460	86.5	0.73	5.96/2.98	830	6.06	245	280	56	55
HES2-12-184TD	2	184TD	1175	230/460	88.5	0.68	6.26/3.13	790	8.99	180	260	55	105
HES3-36-182TD	3	182TD	3520	230/460	86.5	0.85	7.51/3.76	760	4.40	190	260	72	105
HES3-18-182TD	3	182TD	1770	230/460	89.5	0.79	7.81/3.91	930	8.76	220	280	60	105
HES3-12-213TD	3	213TD	1185	230/460	89.5	0.67	9.21/4.6	770	13.08	180	250	57	150
HES5-36-184TD	5	184TD	3515	230/460	88.5	0.86	12.2/6.1	800	7.42	190	260	72	105
HES5-18-184TD	5	184TD	1760	230/460	89.5	0.80	12.97/6.49	840	14.81	210	260	60	105
HES5-12-215TD	5	215TD	1180	230/460	89.5	0.68	15.26/7.63	680	22.09	170	220	57	175
HES7.5-36-213TD	7.5	213TD	3530	230/460	89.5	0.85	18.15/9.07	700	10.98	160	260	73	150
HES7.5-18-213TD	7.5	213TD	1775	230/460	91.7	0.77	19.55/9.78	940	21.83	190	250	62	150
HES7.5-12-254TD	7.5	254TD	1175	230/460	91.0	0.75	20.23/10.11	640	32.98	170	250	64	240
HES10-36-215TD	10	215TD	3525	230/460	90.2	0.86	24.27/12.13	680	14.99	160	260	73	175
HES10-18-215TD	10	215TD	1770	230/460	91.7	0.79	25.99/12.99	750	29.85	180	240	62	175
HES10-12-256TD	10	256TD	1175	230/460	91.0	0.75	27.58/13.79	680	44.97	170	250	64	290
HES15-36-254TD	15	254TD	3550	230/460	91.0	0.88	34.5/17.2	710	21.83	150	250	77	240
HES15-18-254TD	15	254TD	1775	230/460	92.4	0.82	36.4/18.2	750	43.66	200	240	70	240
HES15-12-284TD	15	284TD	1175	230/460	91.7	0.77	39.1/19.6	600	65.95	155	240	65	360
HES20-36-256TD	20	256TD	3550	230/460	91.0	0.89	46.5/23.2	740	29.77	150	250	77	290
HES20-18-256TD	20	256TD	1775	230/460	93.0	0.82	49.7/24.8	800	59.53	200	240	70	290
HES20-12-286TD	20	286TD	1175	230/460	91.7	0.77	53.3/26.7	650	89.94	150	230	65	410
HES25-36-284TSD	25	284TSD	3560	230/460	91.7	0.89	56.9/28.5	670	36.61	160	230	80	360
HES25-18-284TD	25	284TD	1775	230/460	93.6	0.81	61.3/30.6	790	73.43	170	220	72	360
HES25-12-324TD	25	324TD	1175	230/460	93.0	0.80	62.4/31.2	720	110.92	170	210	68	550
HES30-36-286TSD	30	286TSD	3560	230/460	91.7	0.89	67.7/33.8	685	43.54	160	230	80	410
HES30-18-286TD	30	286TD	1775	230/460	93.6	0.81	72.8/36.4	740	87.32	170	220	72	410
HES30-12-326TD	30	326TD	1175	230/460	93.0	0.80	74.2/37.1	830	131.91	170	210	68	560
HES40-36-324TSD	40	324TSD	3560	230/460	92.4	0.92	89.1/44.5	850	59.37	150	230	82	550
HES40-18-324TD	40	324TD	1780	230/460	94.1	0.82	97.6/48.8	850	118.74	170	220	74	550
HHI40-12-364TD	40	364TD	1185	230/460	94.1	0.82	97.6/48.8	680	178.36	150	220	73	780
HES50-36-326TSD	50	326TSD	3560	230/460	93.0	0.92	109.1/54.6	850	73.22	150	230	82	560
HES50-18-326TD	50	326TD	1780	230/460	94.5	0.84	117/58.5	830	146.44	170	220	74	560
HHI50-12-365TD	50	365TD	1185	230/460	94.1	0.82	120.4/60.2	680	219.98	150	220	73	820
HHI60-36-364TSD	60	364TSD	3570	230/460	94.1	0.92	131.2/65.6	680	88.81	140	220	82	780
HHI60-18-364TD	60	364TD	1780	230/460	95.0	0.85	139.9/69.9	670	178.11	150	220	82	780
HHI60-12-404TD	60	404TD	1185	230/460	94.5	0.84	142.3/71.2	670	267.54	140	220	75	1120
HHI75-36-365TSD	75	365TSD	3570	230/460	94.5	0.92	159.7/79.8	680	108.54	140	220	82	820
HHI75-18-365TD	75	365TD	1780	230/460	95.4	0.85	170.3/85.1	690	217.69	150	220	82	820
HHI75-12-405TD	75	405TD	1185	230/460	94.5	0.84	173.9/87	680	326.99	140	220	75	1120
HHI100-36-405TSD	100	405TSD	3570	230/460	94.5	0.91	220.1/110.1	700	148.01	120	220	87	1120
HHI100-18-405TD	100	405TD	1780	230/460	95.4	0.87	228.1/114.1	650	296.85	140	220	82	1120
HHI100-12-444TD	100	444TD	1185	230/460	95	0.85	233.1/116.6	680	445.90	140	220	80	1530
HHI125-36-444TSD	125	444TSD	3570	230/460	95	0.90	278.9/139.5	700	187.48	120	220	92	1610
HHI125-18-444TD	125	444TD	1785	230/460	95.4	0.88	284.1/142	700	374.96	140	220	85	1530
HHI125-12-445TD	125	445TD	1185	230/460	95	0.85	295.3/147.7	675	564.81	140	220	80	1640
HHI150-36-445TSD	150	445TSD	3570	460	95	0.90	323/161.5	700	217.08	120	220	92	1770
HHI150-18-445TD	150	445TD	1785	460	95.8	0.88	327.5/163.8	700	434.16	140	220	85	1640
HHI150-12-447TD	150	447TD	1185	460	95.8	0.85	339.1/169.5	680	653.99	140	220	80	1860
HHI200-36-447TSD	200	447TSD	3570	460	95.4	0.90	438.5/219.3	700	296.02	120	220	92	1900
HHI200-18-447TD	200	447TD	1785	460	96.2	0.88	444.8/222.4	700	592.04	140	220	85	1860
HHI200-12-449TD	200	449TD	1185	460	95.8	0.85	462.4/231.2	680	891.80	140	220	80	2430
HHI250-36-449TSD	250	449TSD	3570	460	95.8	0.90	553.2/276.6	700	374.96	120	220	92	2430
HHI250-18-449TD	250	449TD	1785	460	96.2	0.88	563.4/281.7	700	749.91	140	220	85	2430

* For Electrical performances of 575 V Motor(s), please inquire with us, HD Hyundai Electric America.

HES, HHI Model - Severe duty, Premium Efficiency Three phase, TEFC, C-Face, Footless



Features

- Insulation Class F, Temperature rise B, 40 °C ambient
- 230/460 V (~ 125 HP), 460 V (150 HP ~)
- Cast Iron construction, Direct-on-line & Inverter duty
- IP55, Diagonally split, Gasketed terminal box, Fully rotatable at 90 increments
- Tap provision for Vib. sensor & Bearing Temp. Detector (Except Vib. sensor & Bearing Temp. Detector)

C-Face, Footless

Catalog Number	HP	Frame Number	RPM (Speed)	Volts (V)	FL EFF. (%)	FL PF	FL AMPS (A)	Locked Rotor AMPS (%)	Torque			Sound pressure Level dB(A)	Approx. Weight (LB.)
									Rated (LB.FT)	Locked Rotor %FLT	Break down %FLT		
HES1-36-143TCRD	1	143TC	3490	230/460	77.0	0.82	2.98/1.49	830	1.51	200	270	69	55
HES1-18-143TCRD	1	143TC	1755	230/460	85.5	0.70	3.15/1.57	930	3.01	280	310	56	55
HES1-12-145TCRD	1	145TC	1155	230/460	82.5	0.63	3.62/1.81	800	4.57	180	275	55	55
HES1.5-36-143TCRD	1.5	143TC	3485	230/460	84.0	0.84	3.91/1.96	1000	2.22	185	260	69	55
HES1.5-18-145TCRD	1.5	145TC	1750	230/460	86.5	0.72	4.43/2.22	900	4.43	260	290	56	55
HES1.5-12-182TCRD	1.5	182TC	1175	230/460	87.5	0.61	5.17/2.59	770	6.60	190	270	55	105
HES2-36-145TCRD	2	145TC	3480	230/460	85.5	0.85	5.18/2.59	950	3.04	180	250	69	55
HES2-18-145TCRD	2	145TC	1745	230/460	86.5	0.73	5.96/2.98	830	6.06	245	280	56	55
HES2-12-184TCRD	2	184TC	1175	230/460	88.5	0.68	6.26/3.13	790	8.99	180	260	55	105
HES3-36-182TCRD	3	182TC	3520	230/460	86.5	0.85	7.51/3.76	760	4.40	190	260	72	105
HES3-18-182TCRD	3	182TC	1770	230/460	89.5	0.79	7.81/3.91	930	8.76	220	280	60	105
HES3-12-213TCRD	3	213TC	1185	230/460	89.5	0.67	9.21/4.6	770	13.08	180	250	57	150
HES5-36-184TCRD	5	184TC	3515	230/460	88.5	0.86	12.2/6.1	800	7.42	190	260	72	105
HES5-18-184TCRD	5	184TC	1760	230/460	89.5	0.80	12.97/6.49	840	14.81	210	260	60	105
HES5-12-215TCRD	5	215TC	1180	230/460	89.5	0.68	15.26/7.63	680	22.09	170	220	57	175
HES7.5-36-213TCRD	7.5	213TC	3530	230/460	89.5	0.85	18.15/9.07	700	10.98	160	260	73	150
HES7.5-18-213TCRD	7.5	213TC	1775	230/460	91.7	0.77	19.55/9.78	940	21.83	190	250	62	150
HES7.5-12-254TCRD	7.5	254TC	1175	230/460	91.0	0.75	20.23/10.11	640	32.98	170	250	64	240
HES10-36-215TCRD	10	215TC	3525	230/460	90.2	0.86	24.27/12.13	680	14.99	160	260	73	175
HES10-18-215TCRD	10	215TC	1										

U.S Standard
LV NEMA Motor

HES, HHI Model - Severe duty, Premium Efficiency Three phase, TEFC, D-Flange, Footless



U.S Standard
LV NEMA Motor

HES, HHI Model - Severe duty, Premium Efficiency Three phase, TEFC, Vertical, C-Face, Footless



Features

- Insulation Class F, Temperature rise B, 40 °C ambient
- 230/460 V (~ 125 HP), 460 V (150 HP ~)
- Cast Iron construction, Direct-on-line & Inverter duty
- IP55, Diagonally split, Gasketed terminal box, Fully rotatable at 90 increments
- Tap provision for Vib. sensor & Bearing Temp. Detector (Except Vib. sensor & Bearing Temp. Detector)

D-Flange, Footless

Catalog Number	HP	Frame Number	RPM (Speed)	Volts (V)	FL EFF. (%)	FL PF	FL AMPS (A)	Locked Rotor AMPS (%)	Torque			Sound pressure Level dB(A)	Approx. Weight (LB.)
									Rated (LB.FT)	Locked Rotor %FLT	Break down %FLT		
HES1-36-143TDRD	1	143TD	3490	230/460	77.0	0.82	2.98/1.49	830	1.51	200	270	69	55
HES1-18-143TDRD	1	143TD	1755	230/460	85.5	0.70	3.15/1.57	930	3.01	280	310	56	55
HES1-12-145TDRD	1	145TD	1155	230/460	82.5	0.63	3.62/1.81	800	4.57	180	275	55	55
HES1.5-36-143TDRD	1.5	143TD	3485	230/460	84.0	0.84	3.91/1.96	1000	2.22	185	260	69	55
HES1.5-18-145TDRD	1.5	145TD	1750	230/460	86.5	0.72	4.43/2.22	900	4.43	260	290	56	55
HES1.5-12-182TDRD	1.5	182TD	1175	230/460	87.5	0.61	5.17/2.59	770	6.60	190	270	55	105
HES2-36-145TDRD	2	145TD	3480	230/460	85.5	0.85	5.18/2.59	950	3.04	180	250	69	55
HES2-18-145TDRD	2	145TD	1745	230/460	86.5	0.73	5.96/2.98	830	6.06	245	280	56	55
HES2-12-184TDRD	2	184TD	1175	230/460	88.5	0.68	6.26/3.13	790	8.99	180	260	55	105
HES3-36-182TDRD	3	182TD	3520	230/460	86.5	0.85	7.51/3.76	760	4.40	190	260	72	105
HES3-18-182TDRD	3	182TD	1770	230/460	89.5	0.79	7.81/3.91	930	8.76	220	280	60	105
HES3-12-213TDRD	3	213TD	1185	230/460	89.5	0.67	9.21/4.6	770	13.08	180	250	57	150
HES5-36-184TDRD	5	184TD	3515	230/460	88.5	0.86	12.2/6.1	800	7.42	190	260	72	105
HES5-18-184TDRD	5	184TD	1760	230/460	89.5	0.80	12.97/6.49	840	14.81	210	260	60	105
HES5-12-215TDRD	5	215TD	1180	230/460	89.5	0.68	15.26/7.63	680	22.09	170	220	57	175
HES7.5-36-213TDRD	7.5	213TD	3530	230/460	89.5	0.85	18.15/9.07	700	10.98	160	260	73	150
HES7.5-18-213TDRD	7.5	213TD	1775	230/460	91.7	0.77	19.55/9.78	940	21.83	190	250	62	150
HES7.5-12-254TDRD	7.5	254TD	1175	230/460	91.0	0.75	20.23/10.11	640	32.98	170	250	64	240
HES10-36-215TDRD	10	215TD	3525	230/460	90.2	0.86	24.27/12.13	680	14.99	160	260	73	175
HES10-18-215TDRD	10	215TD	1770	230/460	91.7	0.79	25.99/12.99	750	29.85	180	240	62	175
HES10-12-256TDRD	10	256TD	1175	230/460	91.0	0.75	27.58/13.79	680	44.97	170	250	64	290
HES15-36-254TDRD	15	254TD	3550	230/460	91.0	0.88	34.5/17.2	710	21.83	150	250	77	240
HES15-18-254TDRD	15	254TD	1775	230/460	92.4	0.82	36.4/18.2	750	43.66	200	240	70	240
HES15-12-284TDRD	15	284TD	1175	230/460	91.7	0.77	39.1/19.6	600	65.95	155	240	65	360
HES20-36-256TDRD	20	256TD	3550	230/460	91.0	0.89	46.5/23.2	740	29.77	150	250	77	290
HES20-18-256TDRD	20	256TD	1775	230/460	93.0	0.82	49.7/24.8	800	59.53	200	240	70	290
HES20-12-286TDRD	20	286TD	1175	230/460	91.7	0.77	53.3/26.7	650	89.94	150	230	65	410
HES25-36-284TSDRD	25	284TSD	3560	230/460	91.7	0.89	56.9/28.5	670	36.61	160	230	80	360
HES25-18-284TDRD	25	284TD	1775	230/460	93.6	0.81	61.3/30.6	790	73.43	170	220	72	360
HES25-12-324TDRD	25	324TD	1175	230/460	93.0	0.80	62.4/31.2	720	110.92	170	210	68	550
HES30-36-286TSDRD	30	286TSD	3560	230/460	91.7	0.89	67.7/33.8	685	43.54	160	230	80	410
HES30-18-286TDRD	30	286TD	1775	230/460	93.6	0.81	72.8/36.4	740	87.32	170	220	72	410
HES30-12-326TDRD	30	326TD	1175	230/460	93.0	0.80	74.2/37.1	830	131.91	170	210	68	560
HES40-36-324TSDRD	40	324TSD	3560	230/460	92.4	0.92	89.1/44.5	850	59.37	150	230	82	550
HES40-18-324TDRD	40	324TD	1780	230/460	94.1	0.82	97.6/48.8	850	118.74	170	220	74	550
HHI40-12-364TDRD	40	364TD	1185	230/460	94.1	0.82	97.6/48.8	680	178.36	150	220	73	780
HES50-36-326TSDRD	50	326TSD	3560	230/460	93.0	0.92	109.1/54.6	850	73.22	150	230	82	560
HES50-18-326TDRD	50	326TD	1780	230/460	94.5	0.84	117/58.5	830	146.44	170	220	74	560
HHI50-12-365TDRD	50	365TD	1185	230/460	94.1	0.82	120.4/60.2	680	219.98	150	220	73	820
HHI60-36-364TSDRD	60	364TSD	3570	230/460	94.1	0.92	131.2/65.6	680	88.81	140	220	82	780
HHI60-18-364TDRD	60	364TD	1780	230/460	95.0	0.85	139.9/69.9	670	178.11	150	220	82	780
HHI60-12-404TDRD	60	404TD	1185	230/460	94.5	0.84	142.3/71.2	670	267.54	140	220	75	1120
HHI75-36-365TSDRD	75	365TSD	3570	230/460	94.5	0.92	159.7/79.8	680	108.54	140	220	82	820
HHI75-18-365TDRD	75	365TD	1780	230/460	95.4	0.85	170.3/85.1	690	217.69	150	220	82	820
HHI75-12-405TDRD	75	405TD	1185	230/460	94.5	0.84	173.9/87	680	326.99	140	220	75	1120
HHI100-36-405TSDRD	100	405TSD	3570	230/460	94.5	0.91	220.1/110.1	700	148.01	120	220	87	1120
HHI100-18-405TDRD	100	405TD	1780	230/460	95.4	0.87	228.1/114.1	650	296.85	140	220	82	1120
HHI100-12-444TDRD	100	444TD	1185	230/460	95	0.85	233.1/116.6	680	445.90	140	220	80	1530
HHI125-36-444TSDRD	125	444TSD	3570	230/460	95	0.90	278.9/139.5	700	187.48	120	220	92	1610
HHI125-18-444TDRD	125	444TD	1785	230/460	95.4	0.88	284.1/142	700	374.96	140	220	85	1530
HHI125-12-445TDRD	125	445TD	1185	230/460	95	0.85	295.3/147.7	675	564.81	140	220	80	1640
HHI150-36-445TSDRD	150	445TSD	3570	460	95	0.90	323/161.5	700	217.08	120	220	92	1770
HHI150-18-445TDRD	150	445TD	1785	460	95.8	0.88	327.5/163.8	700	434.16	140	220	85	1640
HHI150-12-447TDRD	150	447TD	1185	460	95.8	0.85	339.1/169.5	680	653.99	140	220	80	1860
HHI200-36-447TSDRD	200	447TSD	3570	460	95.4	0.90	438.5/219.3	700	296.02	120	220	92	1900
HHI200-18-447TDRD	200	447TD	1785	460	96.2	0.88	444.8/222.4	700	592.04	140	220	85	1860
HHI200-12-449TDRD	200	449TD	1185	460	95.8	0.85	462.4/231.2	680	891.80	140	220	80	2430
HHI250-36-449TSDRD	250	449TSD	3570	460	95.8	0.90	553.2/276.6	700	374.96	120	220	92	2430
HHI250-18-449TDRD	250	449TD	1785	460	96.2	0.88	563.4/281.7	700	749.91	140	220	85	2430

* For Electrical performances of 575 V Motor(s), please inquire with us, HD Hyundai Electric America.

Features

- Insulation Class F, Temperature rise B, 40 °C ambient
- 230/460 V (~ 125 HP), 460 V (150 HP ~)
- Cast Iron construction, Direct-on-line & Inverter duty
- IP55, Diagonally split, Gasketed terminal box, Fully rotatable at 90 increments
- Tap provision for Vib. sensor & Bearing Temp. Detector (Except Vib. sensor & Bearing Temp. Detector)

Vertical, C-Face, Footless

Catalog Number	HP	Frame Number	RPM (Speed)	Volts (V)	FL EFF. (%)	FL PF	FL AMPS (A)	Locked Rotor AMPS (%)	Torque			Sound pressure Level dB(A)	Approx. Weight (LB.)
									Rated (LB.FT)	Locked Rotor %FLT	Break down %FLT		
HES1-36-143TCRDV	1	143TC	3490	230/460	77.0	0.82	2.98/1.49	830	1.51	200	270	69	55
HES1-18-143TCRDV	1	143TC	1755	230/460	85.5	0.70	3.15/1.57	930	3.01	280	310	56	55
HES1-12-145TCRDV	1	145TC	1155	230/460	82.5	0.63	3.62/1.81	800	4.57	180	275	55	55
HES1.5-36-143TCRDV	1.5	143TC	3485	230/460	84.0	0.84	3.91/1.96	1000	2.22	185	260	69	55
HES1.5-18-145TCRDV	1.5	145TC	1750	230/460	86.5	0.72	4.43/2.22	900	4.43	260	290	56	55
HES1.5-12-182TCRDV	1.5	182TC	1175	230/460	87.5	0.61	5.17/2.59	770	6.60	190	270	55	105
HES2-36-145TCRDV	2	145TC	3480	230/460	85.5	0.85	5.18/2.59	950	3.04	180	250	69	55
HES2-18-145TCRDV	2	145TC	1745	230/460	86.5	0.73	5.96/2.98	830	6.06	245	280	56	55
HES2-12-184TCRDV	2	184TC	1175	230/460	88.5	0.68	6.26/3.13	790	8.99	180	260	55	105
HES3-36-182TCRDV	3	182TC	3520	230/460	86.5	0.85	7.51/3.76	760	4.40	190	260	72	105
HES3-18-182TCRDV	3	182TC	1770	230/460	89.5	0.79	7.81/3.91	930	8.76	220	280	60	105
HES3-12-213TCRDV	3	213TC	1185	230/460	89.5	0.67	9.21/4.6	770	13.08	180	250	57	150
HES5-36-184TCRDV	5	184TC	3515	230/460	88.5	0.86	12.2/6.1	800	7.42	190	260	72	105
HES5-18-184TCRDV	5	184TC	1760	230/460	89.5	0.80	12.97/6.49	840	14.81	210	260	60	105
HES5-12-215TCRDV	5	215TC	1180	230/460	89.5	0.68	15.26/7.63	680	22.09	170	220	57	175
HES7.5-36-213TCRDV	7.5	213TC	3530	230/460	89.5	0.85	18.15/9.07	700	10.98	160	260	73	150
HES7.5-18-213TCRDV	7.5	213TC	1775	230/460	91.7	0.77	19.55/9.78	940	21.83	190	250	62	150
HES7.5-12-254TCRDV	7.5	254TC	1175	230/460	91.0	0.75	20.23/10.11	640	32.98	170	250	64	240
HES10-36-215TCRDV	10	215TC	3525	230/460	90.2								

U.S Standard
LV NEMA Motor

HES, HHI Model - Severe duty, Premium Efficiency Three phase, TEFC, Vertical, D-Flange, Footless



Features

- Insulation Class F, Temperature rise B, 40 °C ambient
- 230/460 V (~ 125 HP), 460 V (150 HP ~)
- Cast Iron construction, Direct-on-line & Inverter duty
- IP55, Diagonally split, Gasketed terminal box, Fully rotatable at 90 increments
- Tap provision for Vib. sensor & Bearing Temp. Detector (Except Vib. sensor & Bearing Temp. Detector)

Vertical, D-Flange, Footless

Catalog Number	HP	Frame Number	RPM (Speed)	Volts (V)	FL EFF. (%)	FL PF	FL AMPS (A)	Locked Rotor AMPS (%)	Torque			Sound pressure Level dB(A)	Approx. Weight (LB.)
									Rated (LB.FT)	Locked Rotor %FLT	Break down %FLT		
HES1-36-143TDRDV	1	143TD	3490	230/460	77.0	0.82	2.98/1.49	830	1.51	200	270	69	55
HES1-18-143TDRDV	1	143TD	1755	230/460	85.5	0.70	3.15/1.57	930	3.01	280	310	56	55
HES1-12-145TDRDV	1	145TD	1155	230/460	82.5	0.63	3.62/1.81	800	4.57	180	275	55	55
HES1.5-36-143TDRDV	1.5	143TD	3485	230/460	84.0	0.84	3.91/1.96	1000	2.22	185	260	69	55
HES1.5-18-145TDRDV	1.5	145TD	1750	230/460	86.5	0.72	4.43/2.22	900	4.43	260	290	56	55
HES1.5-12-182TDRDV	1.5	182TD	1175	230/460	87.5	0.61	5.17/2.59	770	6.60	190	270	55	105
HES2-36-145TDRDV	2	145TD	3480	230/460	85.5	0.85	5.18/2.59	950	3.04	180	250	69	55
HES2-18-145TDRDV	2	145TD	1745	230/460	86.5	0.73	5.96/2.98	830	6.06	245	280	56	55
HES2-12-184TDRDV	2	184TD	1175	230/460	88.5	0.68	6.26/3.13	790	8.99	180	260	55	105
HES3-36-182TDRDV	3	182TD	3520	230/460	86.5	0.85	7.51/3.76	760	4.40	190	260	72	105
HES3-18-182TDRDV	3	182TD	1770	230/460	89.5	0.79	7.81/3.91	930	8.76	220	280	60	105
HES3-12-213TDRDV	3	213TD	1185	230/460	89.5	0.67	9.21/4.6	770	13.08	180	250	57	150
HES5-36-184TDRDV	5	184TD	3515	230/460	88.5	0.86	12.2/6.1	800	7.42	190	260	72	105
HES5-18-184TDRDV	5	184TD	1760	230/460	89.5	0.80	12.97/6.49	840	14.81	210	260	60	105
HES5-12-215TDRDV	5	215TD	1180	230/460	89.5	0.68	15.26/7.63	680	22.09	170	220	57	175
HES7.5-36-213TDRDV	7.5	213TD	3530	230/460	89.5	0.85	18.15/9.07	700	10.98	160	260	73	150
HES7.5-18-213TDRDV	7.5	213TD	1775	230/460	91.7	0.77	19.55/9.78	940	21.83	190	250	62	150
HES7.5-12-254TDRDV	7.5	254TD	1175	230/460	91.0	0.75	20.23/10.11	640	32.98	170	250	64	240
HES10-36-215TDRDV	10	215TD	3525	230/460	90.2	0.86	24.27/12.13	680	14.99	160	260	73	175
HES10-18-215TDRDV	10	215TD	1770	230/460	91.7	0.79	25.99/12.99	750	29.85	180	240	62	175
HES10-12-256TDRDV	10	256TD	1175	230/460	91.0	0.75	27.58/13.79	680	44.97	170	250	64	290
HES15-36-254TDRDV	15	254TD	3550	230/460	91.0	0.88	34.5/17.2	710	21.83	150	250	77	240
HES15-18-254TDRDV	15	254TD	1775	230/460	92.4	0.82	36.4/18.2	750	43.66	200	240	70	240
HES15-12-284TDRDV	15	284TD	1175	230/460	91.7	0.77	39.1/19.6	600	65.95	155	240	65	360
HES20-36-256TDRDV	20	256TD	3550	230/460	91.0	0.89	46.5/23.2	740	29.77	150	250	77	290
HES20-18-256TDRDV	20	256TD	1775	230/460	93.0	0.82	49.7/24.8	800	59.53	200	240	70	290
HES20-12-286TDRDV	20	286TD	1175	230/460	91.7	0.77	53.3/26.7	650	89.94	150	230	65	410
HES25-36-284TDRDV	25	284TSD	3560	230/460	91.7	0.89	56.9/28.5	670	36.61	160	230	80	360
HES25-18-284TDRDV	25	284TD	1775	230/460	93.6	0.81	61.3/30.6	790	73.43	170	220	72	360
HES25-12-324TDRDV	25	324TD	1175	230/460	93.0	0.80	62.4/31.2	720	110.92	170	210	68	550
HES30-36-286TSDRDV	30	286TSD	3560	230/460	91.7	0.89	67.7/33.8	685	43.54	160	230	80	410
HES30-18-286TDRDV	30	286TD	1775	230/460	93.6	0.81	72.8/36.4	740	87.32	170	220	72	410
HES30-12-326TDRDV	30	326TD	1175	230/460	93.0	0.80	74.2/37.1	830	131.91	170	210	68	560
HES40-36-324TSDRDV	40	324TSD	3560	230/460	92.4	0.82	89.1/44.5	850	59.37	150	230	82	550
HES40-18-324TDRDV	40	324TD	1780	230/460	94.1	0.82	97.6/48.8	850	118.74	170	220	74	550
HHI40-12-364TDRDV	40	364TD	1185	230/460	94.1	0.82	97.6/48.8	680	178.36	150	220	73	780
HES50-36-326TSDRDV	50	326TSD	3560	230/460	93.0	0.92	109.1/54.6	850	73.22	150	230	82	560
HES50-18-326TDRDV	50	326TD	1780	230/460	94.5	0.84	117/58.5	830	146.44	170	220	74	560
HHI50-12-365TDRDV	50	365TD	1185	230/460	94.1	0.82	120.4/60.2	680	219.98	150	220	73	820
HHI60-36-364TSDRDV	60	364TSD	3570	230/460	94.1	0.92	131.2/65.6	680	88.81	140	220	82	780
HHI60-18-364TDRDV	60	364TD	1780	230/460	95.0	0.85	139.9/69.9	670	178.11	150	220	82	780
HHI60-12-404TDRDV	60	404TD	1185	230/460	94.5	0.84	142.3/71.2	670	267.54	140	220	75	1120
HHI75-36-365TSDRDV	75	365TSD	3570	230/460	94.5	0.92	159.7/79.8	680	108.54	140	220	82	820
HHI75-18-365TDRDV	75	365TD	1780	230/460	95.4	0.85	170.3/85.1	690	217.69	150	220	82	820
HHI75-12-405TDRDV	75	405TD	1185	230/460	94.5	0.84	173.9/87	680	326.99	140	220	75	1120
HHI100-36-405TSDRDV	100	405TSD	3570	230/460	94.5	0.91	220.1/110.1	700	148.01	120	220	87	1120
HHI100-18-405TDRDV	100	405TD	1780	230/460	95.4	0.87	228.1/114.1	650	296.85	140	220	82	1120
HHI100-12-444TDRDV	100	444TD	1185	230/460	95	0.85	233.1/116.6	680	445.90	140	220	80	1530
HHI125-36-444TSDRDV	125	444TSD	3570	230/460	95	0.90	278.9/139.5	700	187.48	120	220	92	1610
HHI125-18-444TDRDV	125	444TD	1785	230/460	95.4	0.88	284.1/142	700	374.96	140	220	85	1530
HHI125-12-445TDRDV	125	445TD	1185	230/460	95	0.85	295.3/147.7	675	564.81	140	220	80	1640
HHI150-36-445TSDRDV	150	445TSD	3570	460	95	0.90	323/161.5	700	217.08	120	220	92	1770
HHI150-18-445TDRDV	150	445TD	1785	460	95.8	0.88	327.5/163.8	700	434.16	140	220	85	1640
HHI150-12-447TDRDV	150	447TD	1185	460	95.8	0.85	339.1/169.5	680	653.99	140	220	80	1860
HHI200-36-447TSDRDV	200	447TSD	3570	460	95.4	0.90	438.5/219.3	700	296.02	120	220	92	1900
HHI200-18-447TDRDV	200	447TD	1785	460	96.2	0.88	444.8/222.4	700	592.04	140	220	85	1860
HHI200-12-449TDRDV	200	449TD	1185	460	95.8	0.85	462.4/231.2	680	891.80	140	220	80	2430
HHI250-36-449TSDRDV	250	449TSD	3570	460	95.8	0.90	553.2/276.6	700	374.96	120	220	92	2430
HHI250-18-449TDRDV	250	449TD	1785	460	96.2	0.88	563.4/281.7	700	749.91	140	220	85	2430

* For Electrical performances of 575 V Motor(s), please inquire with us, HD Hyundai Electric America.

U.S Standard
LV NEMA Motor

IEEE HL Model - IEEE841, Premium Efficiency Three phase, TEFC, Foot mounted



Features

- Insulation Class F, Temperature rise B, 40 °C ambient
- Cast Iron construction, 460 V, Direct-on-line & Inverter duty
- IP55, Diagonally split, Gasketed terminal box, Fully rotatable at 90 increments
- Protech seal
- Tap provision for Vib. sensor & Bearing Temp. Detector (Except Vib. sensor & Bearing Temp. Detector)

Foot Mounted

Catalog Number	HP	Frame Number	RPM (SPEED)	Volts (V)	FL EFF. (%)	FL PF	FL AMPS (A)	Locked Rotor AMPS (%)	Torque			Sound pressure Level dB(A)	Approx. Weight (LB.)
									Rated (LB.FT)	Locked Rotor %FLT	Break down %FLT		
IEEE1-36-143T	1	143T	3490	460	77.0	0.82	1.49	830	1.51	200	270	69	55
IEEE1-18-143T	1	143T	1755	460	85.5	0.70	1.57	930	3.01	280	310	56	53
IEEE1-12-145T	1	145T	1155	460	82.5	0.63	1.81	800	4.57	180	275	55	55
IEEE1.5-36-143T	1.5	143T	3485	460	84.0	0.84	1.96	1000	2.22	185	260	69	53
IEEE1.5-18-145T	1.5	145T	1750	460	86.5	0.72	2.22	900	4.43	260	290	56	55
IEEE1.5-12-182T	1.5	182T	1175	460	87.5	0.61	2.59	770	6.60	190	270	55	105
IEEE2-36-145T	2	145T	3480	460	85.5	0.85	2.59	950	3.04	180	250	69	55
IEEE2-18-145T	2	145T	1745	460	86.5	0.73	2.98	830	6.06	245	280	56	55
IEEE2-12-184T	2	184T	1175	460	88.5	0.68	3.13	790	8.99	180	260	55	105
IEEE3-36-182T	3	182T	3520	460	86.5	0.85	3.76	760	4.40	190	260	72	105
IEEE3-18-182T	3	182T	1770	460	89.5	0.79	3.91	930	8.76	220	280	60	105
IEEE3-12-213T	3	213T	1185	460	89.5	0.67	4.60	770	13.08	180	250	57	150
IEEE5-36-184T	5	184T	3515	460	88.5	0.86	6.10	800	7.42	190	260	72	105
IEEE5-18-184T	5	184T	1760	460	89.5	0.80	6.49	840	14.81	210	260	60	105
IEEE5-12-215T	5	215T	1180	460	89.5	0.68	7.63	680	22.09	170	220	57	175
IEEE7.5-36-213T	7.5	213T	3530	460	89.5	0.85	9.07	700	10.98	160	260	73	150
IEEE7.5-18-213T	7.5	213T	1775	460	91.7	0.77	9.78	940	21.83	190	250	62	150
IEEE7.5-12-254T	7.5	254T	1175	460	91.0	0.75	10.11	640	32.98	170	250	64	240
IEEE10-36-215T	10	215T	3525	460	90.2	0.86	12.13	680	14.99	160	260	73	175
IEEE10-18-215T	10	215T	1770	460	91.7	0.79	12.99	750	29.85	180	240	62	175
IEEE10-12-256T	10	2											

IEEE XL Model - IEEE841, Large motor Three phase, TEFC, Foot mounted



IEEE HL Model - IEEE841, Premium Efficiency Three phase, TEFC, C-face, Foot mounted



Features

- Insulation Class F, Temperature rise B or F, 40 °C ambient
- Cast Iron construction, 460 V, Direct-on-line & Inverter duty
- Labyrinth seal (at 3600 RPM Motor), Protech seal (at 1800, 1200 RPM Motor)
- WTD PT 100 Ohm 2 EA/Phase
- BTD PT 100 Ohm 1 EA/Bearing
- Heater 1 EA/Motor
- Auxiliary Terminal Box 2 EA/Motor
- Tap provision for Vib. sensor (Except Vib. sensor)

Catalog Number Suffix

- BB : Ball Bearing
- IB : Insulation Bearing on N-DE
- 2IB : Insulation Bearing on DE & N-DE
- BR : Bearing RTDs (1 EA/Bearing) with Aux. T/box
- SR : Stator RTDs (2 EA/Ph.) with Aux. T/box
- SH : Space Heater (1 EA/Motor) with Aux. T/box
- SP : Spare part (Spare cooling fan)
- LL : Long lead cable
- F : Temp. rise F (Standard Temp. rise B at Ambient temp. 40 °C)

Foot Mounted

Catalog Number	HP	Frame Number	RPM (SPEED)	Volts (V)	FL EFF. (%)	FL PF	FL AMPS (A)	Locked Rotor AMPS (%)	Torque			Sound pressure Level dB(A)	Approx. Weight (LB.)
									Rated (LB.FT)	Locked Rotor %FLT	Break down %FLT		
IEEE250-12-L449T-IBBRSRSH	250	L449T	1185	460	95.8	0.84	296.3	680	1129.6	135	200	80	2890
IEEE300-36-L449TS-IBBRSRSHSP	300	L449TS	3570	460	95.8	0.90	327.5	700	444.0	130	225	87	2890
IEEE300-18-L449T-IBBRSRSH	300	L449T	1785	460	96.2	0.88	333.6	710	888.1	135	225	85	2890
IEEE300-12-L449T-IBBRSRSH	300	L449T	1185	460	95.8	0.84	350.9	675	1337.7	135	220	80	3320
IEEE350-36-L449TS-IBBRSRSHSP	350	L449TS	3570	460	95.8	0.90	378.5	700	513.1	130	225	87	3090
IEEE350-18-L449T-IBBRSRSH	350	L449T	1785	460	96.2	0.88	385.5	715	1026.2	135	225	85	3090
IEEE350-12-L449T-IBBRSRSH	350	L449T	1185	460	95.8	0.84	407.1	650	1551.7	120	200	80	3380
IEEE400-36-L449TS-IBBRSRSHSP	400	L449TS	3570	460	95.8	0.90	436.7	680	592.0	145	240	87	3820
IEEE400-18-L449T-IBBRSRSH	400	L449T	1785	460	96.2	0.88	444.8	710	1184.1	135	225	85	3620
IEEE400-12-5009-IBBRSRSH	400	5009	1185	460	95.8	0.84	467.9	680	1783.6	135	220	84	3970
IEEE450-36-5009S-IBBRSRSHSP	450	5009S	3570	460	95.8	0.90	487.7	725	661.1	130	230	87	3860
IEEE450-18-5009-IBBRSRSH	450	5009	1785	460	96.2	0.89	491.1	720	1322.2	135	230	85	3970
IEEE450-12-5009-IBBRSRSH	450	5009	1185	460	95.8	0.84	522.5	675	1991.7	135	220	84	4030
IEEE500-36-5010S-IBBRSRSHSP	500	5010S	3570	460	95.8	0.90	545.9	725	740.0	145	240	87	4800
IEEE500-18-5010-IBBRSRSH	500	5010	1785	460	96.2	0.89	549.7	720	1480.1	135	220	85	4820
IEEE500-12-5011-IBBRSRSH	500	5011	1185	460	95.8	0.84	584.9	675	2229.5	135	220	84	4850
IEEE600-18-5011-IBBRSRSH	600	5011	1785	460	96.2	0.89	659.7	720	1776.1	135	230	85	4940
IEEE600-36-5812S-IBBRSRSHSP	600	5812S	3570	460	95.8	0.89	662.4	670	888.1	150	250	89	6730
IEEE600-12-5812-IBBRSRSH-F	600	5812	1185	460	95.8	0.84	701.9	675	2675.4	135	220	85	6019
IEEE700-36-5812S-IBBRSRSHSP	700	5812S	3570	460	95.8	0.89	768.4	720	1030.1	150	250	89	6730
IEEE700-18-5812-IBBRSRSH	700	5812	1785	460	96.2	0.88	771.0	650	2052.4	120	220	87	7174
IEEE750-36-5812S-IBBRSRSHSP	750	5812S	3570	460	95.8	0.89	824.4	710	1105.1	150	250	89	6730
IEEE800-36-5812S-IBBRSRSHSP	800	5812S	3570	460	95.8	0.89	883.2	650	1184.1	130	240	89	6730
IEEE900-36-5812S-IBBRSRSHSP-F	900	5812S	3570	460	95.8	0.89	987.8	700	1324.2	150	250	89	7130
IEEE250-12-L449T-IBSH	250	L449T	1185	460	95.8	0.84	296.3	680	1129.6	135	200	80	2890
IEEE300-36-L449TS-IBSHSP	300	L449TS	3570	460	95.8	0.90	327.5	700	444.0	130	225	87	2890
IEEE300-18-L449T-IBSH	300	L449T	1785	460	96.2	0.88	333.6	710	888.1	135	225	85	2890
IEEE300-12-L449T-IBSH	300	L449T	1185	460	95.8	0.84	350.9	675	1337.7	135	220	80	3320
IEEE350-36-L449TS-IBSHSP	350	L449TS	3570	460	95.8	0.90	378.5	700	513.1	130	225	87	3090
IEEE350-18-L449T-IBSH	350	L449T	1785	460	96.2	0.88	385.5	715	1026.2	135	225	85	3090
IEEE350-12-L449T-IBSH	350	L449T	1185	460	95.8	0.84	407.1	650	1551.7	120	200	80	3380
IEEE400-36-L449TS-IBSHSP	400	L449TS	3570	460	95.8	0.90	436.7	680	592.0	145	240	87	3820
IEEE400-18-L449T-IBSH	400	L449T	1785	460	96.2	0.88	444.8	710	1184.1	135	225	85	3620
IEEE400-12-5009-IBSH	400	5009	1185	460	95.8	0.84	467.9	680	1783.6	135	220	84	3970
IEEE450-36-5009S-IBSHSP	450	5009S	3570	460	95.8	0.90	487.7	725	661.1	130	230	87	3860
IEEE450-18-5009-IBSH	450	5009	1785	460	96.2	0.89	491.1	720	1322.2	135	230	85	3970
IEEE450-12-5009-IBSH	450	5009	1185	460	95.8	0.84	522.5	675	1991.7	135	220	84	4030
IEEE500-36-5010S-IBSHSP	500	5010S	3570	460	95.8	0.90	545.9	725	740.0	145	240	87	4800
IEEE500-18-5010-IBSH	500	5010	1785	460	96.2	0.89	549.7	720	1480.1	135	220	85	4820
IEEE500-12-5011-IBSH	500	5011	1185	460	95.8	0.84	584.9	675	2229.5	135	220	84	4850
IEEE600-18-5011-IBSH	600	5011	1785	460	96.2	0.89	659.7	720	1776.1	135	230	85	4940
IEEE600-36-5812S-IBSHSP	600	5812S	3570	460	95.8	0.89	662.4	670	888.1	150	250	89	6730
IEEE600-12-5812-IBSH-F	600	5812	1185	460	95.8	0.84	701.9	675	2675.4	135	220	85	6019
IEEE700-36-5812S-IBSHSP	700	5812S	3570	460	95.8	0.89	768.4	720	1030.1	150	250	89	6730
IEEE700-18-5812-IBSH	700	5812	1785	460	96.2	0.88	771.0	650	2052.4	120	220	87	7174
IEEE750-36-5812S-IBSHSP	750	5812S	3570	460	95.8	0.89	824.4	710	1105.1	150	250	89	6730
IEEE800-36-5812S-IBSHSP	800	5812S	3570	460	95.8	0.89	883.2	650	1184.1	130	240	89	6730
IEEE900-36-5812S-IBSHSP-F	900	5812S	3570	460	95.8	0.89	987.8	700	1324.2	150	250	89	7130

* For Electrical performances of 575 V Motor(s), please inquire with us, HD Hyundai Electric America.

* Remarks

1. Applicable to Each single of accessory (Ex. IB, SH, IBSH & etc.)
2. Standard temperature rise B for HSDE Model (Except 900 HP Motor)
3. Motor power(HP) for HSDE model : Up to 900 HP

Features

- Insulation Class F, Temperature rise B, 40 °C ambient
- Cast Iron construction, 460 V, Direct-on-line & Inverter duty
- IP55, Diagonally split, Gasketed terminal box, Fully rotatable at 90 increments
- Protech seal
- Tap provision for Vib. sensor & Bearing Temp. Detector (Except Vib. sensor & Bearing Temp. Detector)

C-Face, Foot Mounted

Catalog Number	HP	Frame Number	RPM (SPEED)	Volts (V)	FL EFF. (%)	FL PF	FL AMPS (A)	Locked Rotor AMPS (%)	Torque			Sound pressure Level dB(A)	Approx. Weight (LB.)
									Rated (LB.FT)	Locked Rotor %FLT	Break down %FLT		
IEEE1-36-143TC	1	143TC	3490	460	77.0	0.82	1.49	830	1.51	200	270	69	53
IEEE1-18-143TC	1	143TC	1755	460	85.5	0.70	1.57	930	3.01	280	310	56	53
IEEE1-12-145TC	1	145TC	1155	460	82.5	0.63	1.81	800	4.57	180	275	55	55
IEEE1.5-36-143TC	1.5	143TC	3485	460	84.0	0.84	1.96	1000	2.22	185	260	69	53
IEEE1.5-18-145TC	1.5	145TC	1750	460	86.5	0.72	2.22	900	4.43	260	290	56	55
IEEE1.5-12-182TC	1.5	182TC	1175	460	87.5	0.61	2.59	770	6.60	190	270	55	105
IEEE2-36-145TC	2	145TC	3480	460	85.5	0.85	2.59	950	3.04	180	250	69	55
IEEE2-18-145TC	2	145TC	1745	460	86.5	0.73	2.98	830	6.06	245	280	56	55
IEEE2-12-184TC	2	184TC	1175	460	88.5	0.68	3.13	790	8.99	180	260	55	105
IEEE3-36-182TC	3	182TC	3520	460	86.5	0.85	3.76	760	4.40	190	260	72	105
IEEE3-18-182TC	3	182TC	1770	460	89.5	0.79	3.91	930	8.76	220	280	60	105
IEEE3-12-213TC	3	213TC	1185	460	89.5	0.67	4.60	770	13.08	180	250	57	150
IEEE5-36-184TC	5	184TC	3515	460	88.5	0.86	6.10	800	7.42	190	260	72	105
IEEE5-18-184TC	5	184TC	1760	460	89.5	0.80	6.49	840	14.81	210	260	60	105
IEEE5-12-215TC	5	215TC	1180	460	89.5	0.68	7.63	680	22.09	170	220	57	175
IEEE7.5-36-213TC	7.5	213TC	3530	460	89.5	0.85	9.07	700	10.98	160	260	73	150
IEEE7.5-18-213TC	7.5	213TC	1775	460	91.7	0.77	9.78	940	21.83	190	250	62	150
IEEE7.5-12-254TC	7.5	254TC	1175	460	91.0	0.75	10.11	640	32.98	170	250	64	240
IEEE10-36-215TC	10	215TC	3525	460	90.2	0.86	12.13	680	14.99	160	260	73	175
IEEE10-18-215TC	10	215TC	1770	460	91.7	0.79	12.99	750	29.85	180	240	62	175
IEEE10-12-256TC	10	256TC	1175	460	91.0	0.75	13.79	680	44.97	170	250	64	290
IEEE15-36-254TC	15	254TC	3550	460	91.0	0.88	17.24	710	21.83	150	250	77	240
IEEE15-18-254TC	15	254TC	1775	460	92.4	0.82	18.22	750	43.66	200	240	70	240
IEEE15-12-284TC	15	284TC	1175	460	91.7	0.77	19.55	600	65.95	155	240	65	360
IEEE20-36-256TC	20	256TC	3550	460	91.0	0.89	23.25	740	29.77	150	250	77	290
IEEE20-18-256TC	20	256TC	1775	460	93.0	0.82	24.84	800	59.53	200	240	70	290
IEEE20-12-286TC	20	286TC	1175	460	91.7	0.77	26.66	650	89.94	150	230	65	410
IEEE25-36-284TSC	25	284TSC	3560	460	91.7	0.89	28.45	670	36.61	160	230	80	360
IEEE25-18-284TC	25	284TC	1775	460	93.6	0.81	30.63	790	73.43	170	220	72	360
IEEE25-12-324TC	25	324TC	1175	460									

IEEE XL Model - IEEE841, Large motor Three phase, TEFC, C-face, Foot mounted

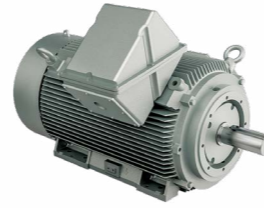

IEEE HL Model - IEEE841, Premium Efficiency Three phase, TEFC, D-Flange, Foot mounted



Features

- Insulation Class F, Temperature rise B or F, 40 °C ambient
- Cast Iron construction, 460 V, Direct-on-line & Inverter duty
- Labyrinth seal (at 3600 RPM Motor),
Protech seal (at 1800, 1200 RPM Motor)
- WTD PT 100 Ohm 2 EA/Phase
- BTD PT 100 Ohm 1 EA/Bearing
- Heater 1 EA/Motor
- Auxiliary Terminal Box 2 EA/Motor
- Tap provision for Vib. sensor (Except Vib. sensor)

Catalog Number Suffix

- BB : Ball Bearing
- IB : Insulation Bearing on N-DE
- 2IB : Insulation Bearing on DE & N-DE
- BR : Bearing RTDs (1 EA/Bearing) with Aux. T/box
- SR : Stator RTDs (2 EA/Ph.) with Aux. T/box
- SH : Space Heater (1 EA/Motor) with Aux. T/box
- SP : Spare part (Spare cooling fan)
- LL : Long lead cable
- F : Temp. rise F (Standard Temp. rise B at Ambient temp. 40 °C)

C-Face, Foot Mounted

Catalog Number	HP	Frame Number	rpm r/min	Volts (V)	FL EFF. (%)	FL PF	FL AMPS (A)	Locked Rotor AMPS (%)	Torque			Sound pressure Level dB(A)	Approx. Weight (LB.)
									Rated (LB.FT)	Locked Rotor %FLT	Break down %FLT		
IEEE250-12-L449TC-IBBRSRSH	250	L449TC	1185	460	95.8	0.84	296.3	680	1129.6	135	200	80	2890
IEEE300-36-L449TSC-IBBRSRSHSP	300	L449TSC	3570	460	95.8	0.90	327.5	700	444.0	130	225	87	2890
IEEE300-18-L449TC-IBBRSRSH	300	L449TC	1785	460	96.2	0.88	333.6	710	888.1	135	225	85	2890
IEEE300-12-L449TC-IBBRSRSH	300	L449TC	1185	460	95.8	0.84	350.9	675	1337.7	135	220	80	3320
IEEE350-36-L449TSC-IBBRSRSHSP	350	L449TSC	3570	460	95.8	0.90	378.5	700	513.1	130	225	87	3090
IEEE350-18-L449TC-IBBRSRSH	350	L449TC	1785	460	96.2	0.88	385.5	715	1026.2	135	225	85	3090
IEEE350-12-L449TC-IBBRSRSH	350	L449TC	1185	460	95.8	0.84	407.1	650	1551.7	120	200	80	3380
IEEE400-36-L449TSC-IBBRSRSHSP	400	L449TSC	3570	460	95.8	0.90	436.7	680	592.0	145	240	87	3820
IEEE400-18-L449TC-IBBRSRSH	400	L449TC	1785	460	96.2	0.88	444.8	710	1184.1	135	225	85	3620
IEEE400-12-5009C-IBBRSRSH	400	5009C	1185	460	95.8	0.84	467.9	680	1783.6	135	220	84	3970
IEEE450-36-5009SC-IBBRSRSHSP	450	5009SC	3570	460	95.8	0.90	487.7	725	661.1	130	230	87	3860
IEEE450-18-5009C-IBBRSRSH	450	5009C	1785	460	96.2	0.89	491.1	720	1322.2	135	230	85	3970
IEEE450-12-5009C-IBBRSRSH	450	5009C	1185	460	95.8	0.84	522.5	675	1991.7	135	220	84	4030
IEEE500-36-5010SC-IBBRSRSHSP	500	5010SC	3570	460	95.8	0.90	545.9	725	740.0	145	240	87	4800
IEEE500-18-5010C-IBBRSRSH	500	5010C	1785	460	96.2	0.89	549.7	720	1480.1	135	220	85	4820
IEEE500-12-5011C-IBBRSRSH	500	5011C	1185	460	95.8	0.84	584.9	675	2229.5	135	220	84	4850
IEEE600-18-5011C-IBBRSRSH	600	5011C	1785	460	96.2	0.89	659.7	720	1776.1	135	230	85	4940
IEEE600-36-5812SC-IBBRSRSHSP	600	5812SC	3570	460	95.8	0.89	662.4	670	888.1	150	250	89	6730
IEEE600-12-5812C-IBBRSRSH-F	600	5812C	1185	460	95.8	0.84	701.9	675	2675.4	135	220	85	6019
IEEE700-36-5812SC-IBBRSRSHSP	700	5812SC	3570	460	95.8	0.89	768.4	720	1030.1	150	250	89	6730
IEEE700-18-5812C-IBBRSRSH	700	5812C	1785	460	96.2	0.88	771.0	650	2052.4	120	220	87	7174
IEEE750-36-5812SC-IBBRSRSHSP	750	5812SC	3570	460	95.8	0.89	824.4	710	1105.1	150	250	89	6730
IEEE800-36-5812SC-IBBRSRSHSP	800	5812SC	3570	460	95.8	0.89	883.2	650	1184.1	130	240	89	6730
IEEE900-36-5812SC-IBBRSRSHSP-F	900	5812SC	3570	460	95.8	0.89	987.8	700	1324.2	150	250	89	7130
IEEE250-12-L449TC-IBSH	250	L449TC	1185	460	95.8	0.84	296.3	680	1129.6	135	200	80	2890
IEEE300-36-L449TSC-IBSHSP	300	L449TSC	3570	460	95.8	0.90	327.5	700	444.0	130	225	87	2890
IEEE300-18-L449TC-IBSH	300	L449TC	1785	460	96.2	0.88	333.6	710	888.1	135	225	85	2890
IEEE300-12-L449TC-IBSH	300	L449TC	1185	460	95.8	0.84	350.9	675	1337.7	135	220	80	3320
IEEE350-36-L449TSC-IBSHSP	350	L449TSC	3570	460	95.8	0.90	378.5	700	513.1	130	225	87	3090
IEEE350-18-L449TC-IBSH	350	L449TC	1785	460	96.2	0.88	385.5	715	1026.2	135	225	85	3090
IEEE350-12-L449TC-IBSH	350	L449TC	1185	460	95.8	0.84	407.1	650	1551.7	120	200	80	3380
IEEE400-36-L449TSC-IBSHSP	400	L449TSC	3570	460	95.8	0.90	436.7	680	592.0	145	240	87	3820
IEEE400-18-L449TC-IBSH	400	L449TC	1785	460	96.2	0.88	444.8	710	1184.1	135	225	85	3620
IEEE400-12-5009C-IBSH	400	5009C	1185	460	95.8	0.84	467.9	680	1783.6	135	220	84	3970
IEEE450-36-5009SC-IBSHSP	450	5009SC	3570	460	95.8	0.90	487.7	725	661.1	130	230	87	3860
IEEE450-18-5009C-IBSH	450	5009C	1785	460	96.2	0.89	491.1	720	1322.2	135	230	85	3970
IEEE450-12-5009C-IBSH	450	5009C	1185	460	95.8	0.84	522.5	675	1991.7	135	220	84	4030
IEEE500-36-5010SC-IBSHSP	500	5010SC	3570	460	95.8	0.90	545.9	725	740.0	145	240	87	4800
IEEE500-18-5010C-IBSH	500	5010C	1785	460	96.2	0.89	549.7	720	1480.1	135	220	85	4820
IEEE500-12-5011C-IBSH	500	5011C	1185	460	95.8	0.84	584.9	675	2229.5	135	220	84	4850
IEEE600-18-5011C-IBSH	600	5011C	1785	460	96.2	0.89	659.7	720	1776.1	135	230	85	4940
IEEE600-36-5812SC-IBSHSP	600	5812SC	3570	460	95.8	0.89	662.4	670	888.1	150	250	89	6730
IEEE600-12-5812C-IBSH-F	600	5812C	1185	460	95.8	0.84	701.9	675	2675.4	135	220	85	6019
IEEE700-36-5812SC-IBSHSP	700	5812SC	3570	460	95.8	0.89	768.4	720	1030.1	150	250	89	6730
IEEE700-18-5812C-IBSH	700	5812C	1785	460	96.2	0.88	771.0	650	2052.4	120	220	87	7174
IEEE750-36-5812SC-IBSHSP	750	5812SC	3570	460	95.8	0.89	824.4	710	1105.1	150	250	89	6730
IEEE800-36-5812SC-IBSHSP	800	5812SC	3570	460	95.8	0.89	883.2	650	1184.1	130	240	89	6730
IEEE900-36-5812SC-IBSHSP-F	900	5812SC	3570	460	95.8	0.89	987.8	700	1324.2	150	250	89	7130

※ For Electrical performances of 575 V Motor(s), please inquire with us, HD Hyundai Electric America.
※ Remarks

1. Applicable to Each single of accessory (Ex. IB, SH, IBSH & etc.)
2. Standard temperature rise B for HSDE Model (Except 900 HP Motor)
3. Motor power(HP) for HSDE model : Up to 900 HP
4. Applicable to the following mounting type.
 - 1) D-flange with Foot
 - 2) Vertical, C-face without Foot
 - 3) Vertical, D-flange without Foot

Features

- Insulation Class F, Temperature rise B, 40 °C ambient
- Cast Iron construction, 460 V, Direct-on-line & Inverter duty
- IP55, Diagonally split, Gasketed terminal box, Fully rotatable at 90 increments
- Protech seal
- Tap provision for Vib. sensor & Bearing Temp. Detector (Except Vib. sensor & Bearing Temp. Detector)

D-Flange, Foot Mounted

Catalog Number	HP	Frame Number	RPM (SPEED)	Volts (V)	FL EFF. (%)	FL PF	FL AMPS (A)	Locked Rotor AMPS (%)	Torque			Sound pressure Level dB(A)	Approx. Weight (LB.)
									Rated (LB.FT)	Locked Rotor %FLT	Break down %FLT		
IEEE1.5-12-182TD	1.5	182TD	1175	460	87.5	0.61	2.59	770	6.60	190	270	55	105
IEEE2-12-184TD	2	184TD	1175	460	88.5	0.68	3.13	790	8.99	180	260	55	105
IEEE3-36-182TD	3	182TD	3520	460	86.5	0.85	3.76	760	4.40	190	260	72	105
IEEE3-18-182TD	3	182TD	1770	460	89.5	0.79	3.91	930	8.76	220	280	60	105
IEEE3-12-213TD	3	213TD	1185	460	89.5	0.67	4.60	770	13.08	180	250	57	150
IEEE5-36-184TD	5	184TD	3515	460	88.5	0.86	6.10	800	7.42	190	260	72	105
IEEE5-18-184TD	5	184TD	1760	460	89.5	0.80	6.49	840	14.81	210	260	60	105
IEEE5-12-215TD	5	215TD	1180	460	89.5	0.68	7.63	680	22.09	170	220	57	175
IEEE7.5-36-213TD	7.5	213TD	3530	460	89.5	0.85	9.07	700	10.98	160	260	73	150
IEEE7.5-18-213TD	7.5	213TD	1775	460	91.7	0.77	9.78	940	21.83	190	250	62	150
IEEE7.5-12-254TD	7.5	254TD	1175	460	91.0	0.75	10.11	640	32.98	170	250	64	240
IEEE10-36-215TD	10	215TD	3525	460	90.2	0.86	12.13	680	14.99	160	260	73	175
IEEE10-18-215TD	10	215TD	1770	460	91.7	0.79	12.99	750	29.85	180	240	62	175
IEEE10-12-256TD	10	256TD	1175	460	91.0	0.75	13.79	680	44.97	170	250	64	290
IEEE15-36-254TD	15	254TD	3550	460	91.0	0.88	17.24	710	21.83	150	250	77	240
IEEE15-18-254TD	15	254TD	1775	460	92.4	0.82	18.22	750	43.66	200	240	70	240
IEEE15-12-284TD	15	284TD	1175	460	91.7	0.77	19.55	600	65.95	155	240	65	360
IEEE20-36-256TD	20	256TD	3550	460	91.0	0.89	23.25	740	29.77	150	250	77	290
IEEE20-18-256TD	20	256TD	1775	460	93.0	0.82	24.84	800	59.53	200	240	70	290
IEEE20-12-286TD	20	286TD	1175	460	91.7	0.77	26.66	650	89.94	150	230	65	410
IEEE25-36-284TSD	25	284TSD	3560	460	91.7	0.89	28.45	670	36.61	160	230	80	360
IEEE25-18-284TD	25	284TD	1775	460	93.6	0.81	30.63	790	73.43	170	220	72	360
IEEE25-12-324TD	25	324TD	1175	460	93.0	0.80	31.21	720	110.92	170	210	68	550
IEEE30-36-286TSD	30	286TSD	3560	460	91.7	0.89	33.83	685	43.54	160	230	80	410
IEEE30-18-286TD	30	286TD	1775	460	93.6	0.81	36.42	740	87.32	170	220	72	410
IEEE30-12-326TD	30	326TD	1175	460	93.0	0.80	37.11	830	131.91	170	210	68	560
IEEE40-36-324TSD	40	324TSD	3560	460	92.4	0.92	44.54	850	59.37	150	230	82	550
IEEE40-18-324TD	40	324TD	1780	460	94.1	0.82	48.80	850	118.74	170	220	74	550
IEEE40-12-364TD	40	364TD	1185	460									

IEEE HL Model - IEEE841, Premium Efficiency Three phase, TEFC, C-Face, Footless



IEEE HL Model - IEEE841, Premium Efficiency Three phase, TEFC, D-Flange, Footless



Features

- Insulation Class F, Temperature rise B, 40 °C ambient
- Cast Iron construction, 460 V, Direct-on-line & Inverter duty
- IP55, Diagonally split, Gasketed terminal box, Fully rotatable at 90 increments
- Protech seal
- Tap provision for Vib. sensor & Bearing Temp. Detector (Except Vib. sensor & Bearing Temp. Detector)

C-Face, Footless

Catalog Number	HP	Frame Number	RPM (SPEED)	Volts (V)	FL EFF. (%)	FL PF	FL AMPS (A)	Locked Rotor AMPS (%)	Torque			Sound pressure Level dB(A)	Approx. Weight (LB.)
									Rated (LB.FT)	Locked Rotor %FLT	Break down %FLT		
IEEE1-36-143TCRD	1	143TC	3490	460	77.0	0.82	1.49	830	1.51	200	270	69	53
IEEE1-18-143TCRD	1	143TC	1755	460	85.5	0.70	1.57	930	3.01	280	310	56	53
IEEE1-12-145TCRD	1	145TC	1155	460	82.5	0.63	1.81	800	4.57	180	275	55	55
IEEE1-5-36-143TCRD	1.5	143TC	3485	460	84.0	0.84	1.96	1000	2.22	185	260	69	53
IEEE1-5-18-145TCRD	1.5	145TC	1750	460	86.5	0.72	2.22	900	4.43	260	290	56	55
IEEE1-5-12-182TCRD	1.5	182TC	1175	460	87.5	0.61	2.59	770	6.60	190	270	55	105
IEEE2-36-145TCRD	2	145TC	3480	460	85.5	0.85	2.59	950	3.04	180	250	69	55
IEEE2-18-145TCRD	2	145TC	1745	460	86.5	0.73	2.98	830	6.06	245	280	56	55
IEEE2-12-184TCRD	2	184TC	1175	460	88.5	0.68	3.13	790	8.99	180	260	55	105
IEEE3-36-182TCRD	3	182TC	3520	460	86.5	0.85	3.76	760	4.40	190	260	72	105
IEEE3-18-182TCRD	3	182TC	1770	460	89.5	0.79	3.91	930	8.76	220	280	60	105
IEEE3-12-213TCRD	3	213TC	1185	460	89.5	0.67	4.60	770	13.08	180	250	57	150
IEEE5-36-184TCRD	5	184TC	3515	460	88.5	0.86	6.10	800	7.42	190	260	72	105
IEEE5-18-184TCRD	5	184TC	1760	460	89.5	0.80	6.49	840	14.81	210	260	60	105
IEEE5-12-215TCRD	5	215TC	1180	460	89.5	0.68	7.63	680	22.09	170	220	57	175
IEEE7-5-36-213TCRD	7.5	213TC	3530	460	89.5	0.85	9.07	700	10.98	160	260	73	150
IEEE7-5-18-213TCRD	7.5	213TC	1775	460	91.7	0.77	9.78	940	21.83	190	250	62	150
IEEE7-5-12-254TCRD	7.5	254TC	1175	460	91.0	0.75	10.11	640	32.98	170	250	64	240
IEEE10-36-215TCRD	10	215TC	3525	460	90.2	0.86	12.13	680	14.99	160	260	73	175
IEEE10-18-215TCRD	10	215TC	1770	460	91.7	0.79	12.99	750	29.85	180	240	62	175
IEEE10-12-256TCRD	10	256TC	1175	460	91.0	0.75	13.79	680	44.97	170	250	64	290
IEEE15-36-254TCRD	15	254TC	3550	460	91.0	0.88	17.24	710	21.83	150	250	77	240
IEEE15-18-254TCRD	15	254TC	1775	460	92.4	0.82	18.22	750	43.66	200	240	70	240
IEEE15-12-284TCRD	15	284TC	1175	460	91.7	0.77	19.55	600	65.95	155	240	65	360
IEEE20-36-256TCRD	20	256TC	3550	460	91.0	0.89	23.25	740	29.77	150	250	77	290
IEEE20-18-256TCRD	20	256TC	1775	460	93.0	0.82	24.84	800	59.53	200	240	70	290
IEEE20-12-286TCRD	20	286TC	1175	460	91.7	0.77	26.66	650	89.94	150	230	65	410
IEEE25-36-284TCRD	25	284TC	3560	460	91.7	0.89	28.45	670	36.61	160	230	80	360
IEEE25-18-284TCRD	25	284TC	1775	460	93.6	0.81	30.63	790	73.43	170	220	72	360
IEEE25-12-324TCRD	25	324TC	1175	460	93.0	0.80	31.21	720	110.92	170	210	68	550
IEEE30-36-286TCRD	30	286TC	3560	460	91.7	0.89	33.83	685	43.54	160	230	80	410
IEEE30-18-286TCRD	30	286TC	1775	460	93.6	0.81	36.42	740	87.32	170	220	72	410
IEEE30-12-326TCRD	30	326TC	1175	460	93.0	0.80	37.11	830	131.91	170	210	68	560
IEEE40-36-324TCRD	40	324TC	3560	460	92.4	0.92	44.54	850	59.37	150	230	82	550
IEEE40-18-324TCRD	40	324TC	1780	460	94.1	0.82	48.80	850	118.74	170	220	74	550
IEEE40-12-364TCRD	40	364TC	1185	460	94.1	0.82	48.80	680	178.36	150	220	73	780
IEEE50-36-326TCRD	50	326TC	3560	460	93.0	0.92	54.57	850	73.22	150	230	82	560
IEEE50-18-326TCRD	50	326TC	1780	460	94.5	0.84	58.50	830	146.44	170	220	74	560
IEEE50-12-365TCRD	50	365TC	1185	460	94.1	0.82	60.18	680	219.98	150	220	73	820
IEEE60-36-364TCRD	60	364TC	3570	460	94.1	0.92	65.60	680	88.81	140	220	82	780
IEEE60-18-364TCRD	60	364TC	1780	460	95.0	0.85	69.94	670	178.11	150	220	82	780
IEEE60-12-404TCRD	60	404TC	1185	460	94.5	0.84	71.15	670	267.54	140	220	75	1120
IEEE75-36-365TCRD	75	365TC	3570	460	94.5	0.92	79.83	680	108.54	140	220	82	820
IEEE75-18-365TCRD	75	365TC	1780	460	95.4	0.85	85.13	690	217.69	150	220	82	820
IEEE75-12-405TCRD	75	405TC	1185	460	94.5	0.84	86.96	680	326.99	140	220	75	1120
IEEE100-36-405TCRD	100	405TC	3570	460	94.5	0.91	110.07	700	148.01	120	220	85	1120
IEEE100-18-405TCRD	100	405TC	1780	460	95.4	0.87	114.07	650	296.85	140	220	82	1120
IEEE100-12-444TCRD	100	444TC	1185	460	95	0.85	116.57	680	445.90	140	220	80	1530
IEEE125-36-444TCRD	125	444TC	3570	460	95	0.90	139.46	700	187.48	120	220	85	1610
IEEE125-18-444TCRD	125	444TC	1785	460	95.4	0.88	142.03	700	374.96	140	220	80	1860
IEEE125-12-445TCRD	125	445TC	1185	460	95	0.85	147.66	675	564.81	140	220	80	1640
IEEE150-36-445TCRD	150	445TC	3570	460	95	0.90	161.48	700	217.08	120	220	85	1770
IEEE150-18-445TCRD	150	445TC	1785	460	95.8	0.88	163.77	700	434.16	140	220	85	1640
IEEE150-12-447TCRD	150	447TC	1185	460	95.8	0.85	169.55	680	653.99	140	220	80	1860
IEEE200-36-447TCRD	200	447TC	3570	460	95.4	0.90	219.27	700	296.02	120	220	85	1900
IEEE200-18-447TCRD	200	447TC	1785	460	96.2	0.88	222.39	700	592.04	140	220	85	1860
IEEE200-12-449TCRD	200	449TC	1185	460	95.8	0.85	231.20	680	891.80	140	220	80	2430
IEEE250-36-449TCRD	250	449TC	3570	460	95.8	0.90	276.58	700	374.96	120	220	85	2430
IEEE250-18-449TCRD	250	449TC	1785	460	96.2	0.88	281.69	700	749.91	140	220	85	2430

* For Electrical performances of 575 V Motor(s), please inquire with us, HD Hyundai Electric America.

Features

- Insulation Class F, Temperature rise B, 40 °C ambient
- Cast Iron construction, 460 V, Direct-on-line & Inverter duty
- IP55, Diagonally split, Gasketed terminal box, Fully rotatable at 90 increments
- Protech seal
- Tap provision for Vib. sensor & Bearing Temp. Detector (Except Vib. sensor & Bearing Temp. Detector)

D-Flange, Footless

Catalog Number	HP	Frame Number	RPM (SPEED)	Volts (V)	FL EFF. (%)	FL PF	FL AMPS (A)	Locked Rotor AMPS (%)	Torque			Sound pressure Level dB(A)	Approx. Weight (LB.)
									Rated (LB.FT)	Locked Rotor %FLT	Break down %FLT		
IEEE1.5-12-182TCRD	1.5	182TD	1175	460	87.5	0.61	2.59	770	6.60	190	270	55	105
IEEE2-12-184TCRD	2	184TD	1175	460	88.5	0.68	3.13	790	8.99	180	260	55	105
IEEE3-36-182TCRD	3	182TD	3520	460	86.5	0.85	3.76	760	4.40	190	260	72	105
IEEE3-18-182TCRD	3	182TD	1770	460	89.5	0.79	3.91	930	8.76	220	280	60	105
IEEE3-12-213TCRD	3	213TD	1185	460	89.5	0.67	4.60	770	13.08	180	250	57	150
IEEE5-36-184TCRD	5	184TD	3515	460	88.5	0.86	6.10	800	7.42	190	260	72	105
IEEE5-18-184TCRD	5	184TD	1760	460	89.5	0.80	6.49	840	14.81	210	260	60	105
IEEE5-12-215TCRD	5	215TD	1180	460	89.5	0.68	7.63	680	22.09	170	220	57	175
IEEE7-5-36-213TCRD	7.5	213TD	3530	460	89.5	0.85	9.07	700	10.98	160	260	73	150
IEEE7-5-18-213TCRD	7.5	213TD	1775	460	91.7	0.77	9.78	940	21.83	190	250	62	150
IEEE7-5-12-254TCRD	7.5	254TD	1175	460	91.0	0.75	10.11	640	32.98	170	250	64	240
IEEE10-36-215TCRD	10	215TD	3525	460	90.2	0.86	12.13	680	14.99	160	260	73	175
IEEE10-18-215TCRD	10	215TD	1770	460	91.7	0.79	12.99	750	29.85	180	240	62	175
IEEE10-12-256TCRD	10	256TD	1175	460	91.0	0.75	13.79	680	44.97	170	250	64	290
IEEE15-36-254TCRD	15	254TD	3550	460	91.0	0.88	17.24	710	21.83	150	250	77	240
IEEE15-18-254TCRD	15	254TD	1775	460	92.4	0.82	18.22	750	43.66	200	240	70	240
IEEE15-12-284TCRD	15	284TD	1175	460	91.7	0.77	19.55	600	65.95	155	240	65	360
IEEE20-36-256TCRD	20	256TD	3550	460	91.0	0.89	23.25	740	29.77	150	250	77	290
IEEE20-18-256TCRD	20	256TD	1775	460	93.0	0.82	24.84	800	59.53	200	240	70	290
IEEE20-12-286TCRD	20	286TD	1175	460	91.7	0.77	26.66	650	89.94	150	230	65	410
IEEE25-36-284TCRD	25	284TSD	3560	460	91.7	0.89	28.45	670	36.61	160	230	80	360
IEEE25-18-284TCRD	25	284TSD	1775	460	93.6	0.81	30.63	790	73.43	170	220	72	360
IEEE25-12-324TCRD	25	324TSD	1175	460	93.0	0.80	31.21	720	110.92	170	210	68	550
IEEE30-36-286TCRD	30	286TSD	3560	460	91.7	0.89	33.83	685	43.54	160	230	80	410
IEEE30-18-286TCRD	30	286TSD	1										

U.S Standard
LV NEMA Motor

IEEE HL Model - IEEE841, Premium Efficiency Three phase, TEFC, Vertical, C-Face, Footless



U.S Standard
LV NEMA Motor

IEEE HL Model - IEEE841, Premium Efficiency Three phase, TEFC, Vertical, D-Flange, Footless



Features

- Insulation Class F, Temperature rise B, 40 °C ambient
- Cast Iron construction, 460 V, Direct-on-line & Inverter duty
- IP55, Diagonally split, Gasketed terminal box, Fully rotatable at 90 increments
- Protech seal
- Tap provision for Vib. sensor & Bearing Temp. Detector (Except Vib. sensor & Bearing Temp. Detector)

Vertical C-Face, Footless

Catalog Number	HP	Frame Number	RPM (SPEED)	Volts (V)	FL EFF. (%)	FL PF	FL AMPS (A)	Locked Rotor AMPS (%)	Torque			Sound pressure Level dB(A)	Approx. Weight (LB.)
									Rated (LB.FT)	Locked Rotor %FLT	Break down %FLT		
IEEE1-36-143TCRDV	1	143TC	3490	460	77.0	0.82	1.49	830	1.51	200	270	69	53
IEEE1-18-143TCRDV	1	143TC	1755	460	85.5	0.70	1.57	930	3.01	280	310	56	53
IEEE1-12-145TCRDV	1	145TC	1155	460	82.5	0.63	1.81	800	4.57	180	275	55	55
IEEE1.5-36-143TCRDV	1.5	143TC	3485	460	84.0	0.84	1.96	1000	2.22	185	260	69	53
IEEE1.5-18-145TCRDV	1.5	145TC	1750	460	86.5	0.72	2.22	900	4.43	260	290	56	55
IEEE1.5-12-182TCRDV	1.5	182TC	1175	460	87.5	0.61	2.59	770	6.60	190	270	55	105
IEEE2-36-145TCRDV	2	145TC	3480	460	85.5	0.85	2.59	950	3.04	180	250	69	55
IEEE2-18-145TCRDV	2	145TC	1745	460	86.5	0.73	2.98	830	6.06	245	280	56	55
IEEE2-12-184TCRDV	2	184TC	1175	460	88.5	0.68	3.13	790	8.99	180	260	55	105
IEEE3-36-182TCRDV	3	182TC	3520	460	86.5	0.85	3.76	760	4.40	190	260	72	105
IEEE3-18-182TCRDV	3	182TC	1770	460	89.5	0.79	3.91	930	8.76	220	280	60	105
IEEE3-12-213TCRDV	3	213TC	1185	460	89.5	0.67	4.60	770	13.08	180	250	57	150
IEEE5-36-184TCRDV	5	184TC	3515	460	88.5	0.86	6.10	800	7.42	190	260	72	105
IEEE5-18-184TCRDV	5	184TC	1760	460	89.5	0.80	6.49	840	14.81	210	260	60	105
IEEE5-12-215TCRDV	5	215TC	1180	460	89.5	0.68	7.63	680	22.09	170	220	57	175
IEEE7.5-36-213TCRDV	7.5	213TC	3530	460	89.5	0.85	9.07	700	10.98	160	260	73	150
IEEE7.5-18-213TCRDV	7.5	213TC	1775	460	91.7	0.77	9.78	940	21.83	190	250	62	150
IEEE7.5-12-254TCRDV	7.5	254TC	1175	460	91.0	0.75	10.11	640	32.98	170	250	64	240
IEEE10-36-215TCRDV	10	215TC	3525	460	90.2	0.86	12.13	680	14.99	160	260	73	175
IEEE10-18-215TCRDV	10	215TC	1770	460	91.7	0.79	12.99	750	29.85	180	240	62	175
IEEE10-12-256TCRDV	10	256TC	1175	460	91.0	0.75	13.79	680	44.97	170	250	64	290
IEEE15-36-254TCRDV	15	254TC	3550	460	91.0	0.88	17.24	710	21.83	150	250	77	240
IEEE15-18-254TCRDV	15	254TC	1775	460	92.4	0.82	18.22	750	43.66	200	240	70	240
IEEE15-12-284TCRDV	15	284TC	1175	460	91.7	0.77	19.55	600	65.95	155	240	65	360
IEEE20-36-256TCRDV	20	256TC	3550	460	91.0	0.89	23.25	740	29.77	150	250	77	290
IEEE20-18-256TCRDV	20	256TC	1775	460	93.0	0.82	24.84	800	59.53	200	240	70	290
IEEE20-12-286TCRDV	20	286TC	1175	460	91.7	0.77	26.66	650	89.94	150	230	65	410
IEEE25-36-284TCRDV	25	284TSC	3560	460	91.7	0.89	28.45	670	36.61	160	230	80	360
IEEE25-18-284TCRDV	25	284TC	1775	460	93.6	0.81	30.63	790	73.43	170	220	72	360
IEEE25-12-324TCRDV	25	324TC	1175	460	93.0	0.80	31.21	720	110.92	170	210	68	550
IEEE30-36-286TCRDV	30	286TSC	3560	460	91.7	0.89	33.83	685	43.54	160	230	80	410
IEEE30-18-286TCRDV	30	286TC	1775	460	93.6	0.81	36.42	740	87.32	170	220	72	410
IEEE30-12-326TCRDV	30	326TC	1175	460	93.0	0.80	37.11	830	131.91	170	210	68	560
IEEE40-36-324TCRDV	40	324TSC	3560	460	92.4	0.92	44.54	850	59.37	150	230	82	550
IEEE40-18-324TCRDV	40	324TC	1780	460	94.1	0.82	48.80	850	118.74	170	220	74	550
IEEE40-12-364TCRDV	40	364TC	1185	460	94.1	0.82	48.80	680	178.36	150	220	73	780
IEEE50-36-326TCRDV	50	326TSC	3560	460	93.0	0.92	54.57	850	73.22	150	230	82	560
IEEE50-18-326TCRDV	50	326TC	1780	460	94.5	0.84	58.50	830	146.44	170	220	74	560
IEEE50-12-365TCRDV	50	365TC	1185	460	94.1	0.82	60.18	680	219.98	150	220	73	820
IEEE60-36-364TCRDV	60	364TSC	3570	460	94.1	0.92	65.60	680	88.81	140	220	82	780
IEEE60-18-364TCRDV	60	364TC	1780	460	95.0	0.85	69.94	670	178.11	150	220	82	780
IEEE60-12-404TCRDV	60	404TC	1185	460	94.5	0.84	71.15	670	267.54	140	220	75	1120
IEEE75-36-365TCRDV	75	365TSC	3570	460	94.5	0.92	79.83	680	108.54	140	220	82	820
IEEE75-18-365TCRDV	75	365TC	1780	460	95.4	0.85	85.13	690	217.69	150	220	82	820
IEEE75-12-405TCRDV	75	405TC	1185	460	94.5	0.84	86.96	680	326.99	140	220	75	1120
IEEE100-36-405TCRDV	100	405TSC	3570	460	94.5	0.91	110.07	700	148.01	120	220	85	1120
IEEE100-18-405TCRDV	100	405TC	1780	460	95.4	0.87	114.07	650	296.85	140	220	82	1120
IEEE100-12-444TCRDV	100	444TC	1185	460	95	0.85	116.57	680	445.90	140	220	80	1530
IEEE125-36-444TSCRDV	125	444TSC	3570	460	95	0.90	139.46	700	187.48	120	220	85	1610
IEEE125-18-444TCRDV	125	444TC	1785	460	95.4	0.88	142.03	700	374.96	140	220	85	1530
IEEE125-12-445TCRDV	125	445TC	1185	460	95	0.85	147.66	675	564.81	140	220	80	1640
IEEE150-36-445TSCRDV	150	445TSC	3570	460	95	0.90	161.48	700	217.08	120	220	85	1770
IEEE150-18-445TCRDV	150	445TC	1785	460	95.8	0.88	163.77	700	434.16	140	220	85	1640
IEEE150-12-447TCRDV	150	447TC	1185	460	95.8	0.85	169.55	680	653.99	140	220	80	1860
IEEE200-36-447TSCRDV	200	447TSC	3570	460	95.4	0.90	219.27	700	296.02	120	220	85	1900
IEEE200-18-447TCRDV	200	447TC	1785	460	96.2	0.88	222.39	700	592.04	140	220	85	1860
IEEE200-12-449TCRDV	200	449TC	1185	460	95.8	0.85	231.20	680	891.80	140	220	80	2430
IEEE250-36-449TSCRDV	250	449TSC	3570	460	95.8	0.90	276.58	700	374.96	120	220	85	2430
IEEE250-18-449TCRDV	250	449TC	1785	460	96.2	0.88	281.69	700	749.91	140	220	85	2430

* For Electrical performances of 575 V Motor(s), please inquire with us, HD Hyundai Electric America.

Features

- Insulation Class F, Temperature rise B, 40 °C ambient
- Cast Iron construction, 460 V, Direct-on-line & Inverter duty
- IP55, Diagonally split, Gasketed terminal box, Fully rotatable at 90 increments
- Protech seal
- Tap provision for Vib. sensor & Bearing Temp. Detector (Except Vib. sensor & Bearing Temp. Detector)

Vertical D-Flange with Footless Mounted (V1)

Catalog Number	HP	Frame Number	RPM (SPEED)	Volts (V)	FL EFF. (%)	FL PF	FL AMPS (A)	Locked Rotor AMPS (%)	Torque			Sound pressure Level dB(A)	Approx. Weight (LB.)	
									Rated (LB.FT)	Locked Rotor %FLT	Break down %FLT			
IEEE1.5-12-182TDRDV	1.5	182TD	182TD	1175	460	87.5	0.61	2.59	770	6.60	190	270	55	105
IEEE2-12-184TDRDV	2	184TD	184TD	1175	460	88.5	0.68	3.13	790	8.99	180	260	55	105
IEEE3-36-182TDRDV	3	182TD	182TD	3520	460	86.5	0.85	3.76	760	4.40	190	260	72	105
IEEE3-18-182TDRDV	3	182TD	182TD	1770	460	89.5	0.79	3.91	930	8.76	220	280	60	105
IEEE3-12-213TDRDV	3	213TD	213TD	1185	460	89.5	0.67	4.60	770	13.08	180	250	57	150
IEEE5-36-184TDRDV	5	184TD	184TD	3515	460	88.5	0.86	6.10	800	7.42	190	260	72	105
IEEE5-18-184TDRDV	5	184TD	184TD	1760	460	89.5	0.80	6.49	840	14.81	210	260	60	105
IEEE5-12-215TDRDV	5	215TD	215TD	1180	460	89.5	0.68	7.63	680	22.09	170	220	57	175
IEEE7.5-36-213TDRDV	7.5	213TD	213TD	3530	460	89.5	0.85	9.07	700	10.98	160	260	73	150
IEEE7.5-18-213TDRDV	7.5	213TD	213TD	1775	460	91.7	0.77	9.78	940	21.83	190	250	62	150
IEEE7.5-12-254TDRDV	7.5	254TD	254TD	1175	460	91.0	0.75	10.11	640	32.98	170	250	64	240
IEEE10-36-215TDRDV	10	215TD	215TD	3525	460	90.2	0.86	12.13	680	14.99	160	260	73	175
IEEE10-18-215TDRDV	10	215TD	215TD	1770	460	91.7	0.79	12.99	750	29.85	180	240	62	175
IEEE10-12-256TDRDV	10	256TD	256TD	1175	460	91.0	0.75	13.79	680	44.97	170	250	64	290
IEEE15-36-254TDRDV	15	254TD	254TD	3550	460	91.0	0.88	17.24	710	21.83	150	250	77	240
IEEE15-18-254TDRDV	15	254TD	254TD	1775	460	92.4	0.82	18.22	750	43.66	200	240	70	240
IEEE15-12-284TDRDV	15	284TD	284TD	1175	460	91.7	0.77	19.55	600	65.95	155	240	65	360
IEEE20-36-256TDRDV	20	256TD	256TD	3550	460	91.0	0.89	23.25	740	29.77	150	250	77	290
IEEE20-18-256TDRDV	20	256TD	256TD	1775	460	93.0	0.82	24.84	800	59.53	200	240	70	290
IEEE20-12-286TDRDV	20	286TD	286TD	1175	460	91.7	0.77	26.66	650	89.94	150	230	65	410
IEEE25-36-284TSDRDV	25	284TSD	284TSD	3560	460	91.7	0.89	28.45	670	36.61	160	230	80	360
IEEE25-18-284TSDRDV	25	284TD	284TD	1775	460	93.								

U.S Standard
LV NEMA Motor

IXHHI Model - Explosion proof, Premium Efficiency Three phase, TEFC, Foot mounted



U.S Standard
LV NEMA Motor

IXHHI Model - Explosion proof, Premium Efficiency Three phase, TEFC, C-Face, Foot mounted

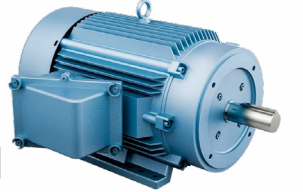

Features

- Insulation Class F, Temperature rise B, 40 °C ambient
- 230/460 V (~ 125 HP), 460 V (150 HP ~ 250 HP)
- Class 1 Division 1 Group C&D Temp. code T4 with Thermostat (1 EA/Ph.)
- Cast Iron construction, Direct-on-line & Inverter duty
- IP55, Diagonally split, Gasketed terminal box, Fully rotatable at 90 increments
- Tap provision for Vib. sensor & Bearing Temp. Detector (Except Vib. sensor & Bearing Temp. Detector)

Foot Mounted

Catalog Number	HP	Frame Number	RPM (Speed)	Volts (V)	FL EFF. (%)	FL PF	FL AMPS (A)	Locked Rotor AMPS (%)	Torque			Sound pressure Level dB(A)	Approx. Weight (LB.)
									Rated (LB.FT)	Locked Rotor %FLT	Break down %FLT		
DXHHI1-36-143T	1	143T	3490	230/460	77.0	0.82	2.98/1.49	830	1.51	200	270	73	64
DXHHI1-18-143T	1	143T	1755	230/460	85.5	0.70	3.15/1.57	930	3.01	280	310	64	64
DXHHI1-12-145T	1	145T	1155	230/460	82.5	0.63	3.62/1.81	800	4.57	180	275	55	66
DXHHI1.5-36-143T	1.5	143T	3485	230/460	84.0	0.84	3.91/1.96	1000	2.22	185	260	73	64
DXHHI1.5-18-145T	1.5	145T	1750	230/460	86.5	0.72	4.43/2.22	900	4.43	260	290	64	66
DXHHI1.5-12-182T	1.5	182T	1175	230/460	87.5	0.61	5.17/2.59	770	6.60	190	270	60	112
DXHHI2-36-145T	2	145T	3480	230/460	85.5	0.85	5.18/2.59	950	3.04	180	250	73	66
DXHHI2-18-145T	2	145T	1745	230/460	86.5	0.73	5.96/2.98	830	6.06	245	280	64	66
DXHHI2-12-184T	2	184T	1175	230/460	88.5	0.68	6.26/3.13	790	8.99	180	260	60	121
DXHHI3-36-182T	3	182T	3520	230/460	86.5	0.85	7.51/3.76	760	4.40	190	260	73	112
DXHHI3-18-182T	3	182T	1770	230/460	89.5	0.79	7.81/3.91	930	8.76	220	280	64	112
DXHHI3-12-213T	3	213T	1185	230/460	89.5	0.67	9.21/4.6	770	13.08	180	250	60	160
DXHHI5-36-184T	5	184T	3515	230/460	88.5	0.86	12.2/6.1	800	7.42	190	260	73	121
DXHHI5-18-184T	5	184T	1760	230/460	89.5	0.80	12.97/6.49	840	14.81	210	260	74	121
DXHHI5-12-215T	5	215T	1180	230/460	89.5	0.68	15.26/7.63	680	22.09	170	220	62	180
DXHHI7.5-36-213T	7.5	213T	3530	230/460	89.5	0.85	18.15/9.07	700	10.98	160	260	76	160
DXHHI7.5-18-213T	7.5	213T	1775	230/460	91.7	0.77	19.55/9.78	940	21.83	190	250	69	160
DXHHI7.5-12-254T	7.5	254T	1175	230/460	91.0	0.75	20.23/10.11	640	32.98	170	250	64	310
DXHHI10-36-215T	10	215T	3525	230/460	90.2	0.86	24.27/12.13	680	14.99	160	260	76	180
DXHHI10-18-215T	10	215T	1770	230/460	91.7	0.79	25.99/12.99	750	29.85	180	240	70	180
DXHHI10-12-256T	10	256T	1175	230/460	91.0	0.75	27.58/13.79	680	44.97	170	250	64	350
DXHHI15-36-254T	15	254T	3550	230/460	91.0	0.88	34.5/17.2	710	21.83	150	250	79	310
DXHHI15-18-254T	15	254T	1775	230/460	92.4	0.82	36.4/18.2	750	43.66	200	240	74	310
DXHHI15-12-284T	15	284T	1175	230/460	91.7	0.77	39.1/19.6	600	65.95	155	240	66	440
DXHHI20-36-256T	20	256T	3550	230/460	91.0	0.89	46.5/23.2	740	29.77	150	250	79	350
DXHHI20-18-256T	20	256T	1775	230/460	93.0	0.82	49.7/24.8	800	59.53	200	240	74	350
DXHHI20-12-286T	20	286T	1175	230/460	91.7	0.77	53.3/26.7	650	89.94	150	230	68	480
DXHHI25-36-284TS	25	284TS	3560	230/460	91.7	0.89	56.9/28.5	670	36.61	160	230	86	440
DXHHI25-18-284T	25	284T	1775	230/460	93.6	0.81	61.3/30.6	790	73.43	170	220	77	440
DXHHI25-12-324T	25	324T	1175	230/460	93.0	0.80	62.4/31.2	720	110.92	170	210	70	820
DXHHI30-36-286TS	30	286TS	3560	230/460	91.7	0.89	67.7/33.8	685	43.54	160	230	86	480
DXHHI30-18-286T	30	286T	1775	230/460	93.6	0.81	72.8/36.4	740	87.32	170	220	77	480
DXHHI30-12-326T	30	326T	1175	230/460	93.0	0.80	74.2/37.1	830	131.91	170	210	70	840
DXHHI40-36-324TS	40	324TS	3560	230/460	92.4	0.92	89.1/44.5	850	59.37	150	230	86	800
DXHHI40-18-324T	40	324T	1780	230/460	94.1	0.82	97.6/48.8	850	118.74	170	220	77	820
DXHHI40-12-364T	40	364T	1185	230/460	94.1	0.82	97.6/48.8	680	178.36	150	220	73	1113
DXHHI50-36-326TS	50	326TS	3560	230/460	93.0	0.92	109.1/54.6	850	73.22	150	230	86	820
DXHHI50-18-326T	50	326T	1780	230/460	94.5	0.84	117/58.5	830	146.44	170	220	77	840
DXHHI50-12-365T	50	365T	1185	230/460	94.1	0.82	120.4/60.2	680	219.98	150	220	73	1173
DXHHI60-36-364TS	60	364TS	3570	230/460	94.1	0.92	131.2/65.6	680	88.81	140	220	82	1047
DXHHI60-18-364T	60	364T	1780	230/460	95.0	0.85	139.9/69.9	670	178.11	150	220	82	1113
DXHHI60-12-404T	60	404T	1185	230/460	94.5	0.84	142.3/71.2	670	267.54	140	220	75	1532
DXHHI75-36-365TS	75	365TS	3570	230/460	94.5	0.92	159.7/79.8	680	108.54	140	220	82	1087
DXHHI75-18-365T	75	365T	1780	230/460	95.4	0.85	170.3/85.1	690	217.69	150	220	82	1153
DXHHI75-12-405T	75	405T	1185	230/460	94.5	0.84	173.9/87	680	326.99	140	220	75	1830
DXHHI100-36-405TS	100	405TS	3570	230/460	94.5	0.91	220.1/110.1	700	148.01	120	220	87	1852
DXHHI100-18-405T	100	405T	1780	230/460	95.4	0.87	228.1/114.1	650	296.85	140	220	82	1830
DXHHI100-12-444T	100	444T	1185	230/460	95	0.85	233.1/116.6	680	445.90	140	220	80	2116
DXHHI125-36-444TS	125	444TS	3570	230/460	95	0.90	278.9/139.5	700	187.48	120	220	92	2006
DXHHI125-18-444T	125	444T	1785	230/460	95.4	0.88	284.1/142	700	374.96	140	220	85	2116
DXHHI125-12-445T	125	445T	1185	230/460	95	0.85	295.3/147.7	675	564.81	140	220	80	2293
DXHHI150-36-445TS	150	445TS	3570	460	95	0.90	323/161.5	700	217.08	120	220	92	2249
DXHHI150-18-445T	150	445T	1785	460	95.8	0.88	327.5/163.8	700	434.16	140	220	85	2293
DXHHI150-12-447T	150	447T	1185	460	95.8	0.85	339.1/169.5	680	653.99	140	220	80	2756
DXHHI200-36-447TS	200	447TS	3570	460	95.4	0.90	438.5/219.3	700	296.02	120	220	92	2690
DXHHI200-18-447T	200	447T	1785	460	96.2	0.88	444.8/222.4	700	592.04	140	220	85	2756
DXHHI200-12-449T	200	449T	1185	460	95.8	0.85	462.4/231.2	680	891.80	140	220	80	3086
DXHHI250-36-449TS	250	449TS	3570	460	95.8	0.90	553.2/276.6	700	374.96	120	220	92	3020
DXHHI250-18-449T	250	449T	1785	460	96.2	0.88	563.4/281.7	700	749.91	140	220	85	3086

※ For Electrical performances of 575 V Motor(s), please inquire with us, HD Hyundai Electric America.

Features

- Insulation Class F, Temperature rise B, 40 °C ambient
- 230/460 V (~ 125 HP), 460 V (150 HP ~ 250 HP)
- Class 1 Division 1 Group C&D Temp. code T4 with Thermostat (1 EA/Ph.)
- Cast Iron construction, Direct-on-line & Inverter duty
- IP55, Diagonally split, Gasketed terminal box, Fully rotatable at 90 increments
- Tap provision for Vib. sensor & Bearing Temp. Detector (Except Vib. sensor & Bearing Temp. Detector)

C-Face, Foot Mounted

Catalog Number	HP	Frame Number	RPM (Speed)	Volts (V)	FL EFF. (%)	FL PF	FL AMPS (A)	Locked Rotor AMPS (%)	Torque			Sound pressure Level dB(A)	Approx. Weight (LB.)
									Rated (LB.FT)	Locked Rotor %FLT	Break down %FLT		
DXHHI1-36-143TC	1	143TC	3490	230/460	77.0	0.82	2.98/1.49	830	1.51	200	270	73	64
DXHHI1-18-143TC	1	143TC	1755	230/460	85.5	0.70	3.15/1.57	930	3.01	280	310	64	64
DXHHI1-12-145TC	1	145TC	1155	230/460	82.5	0.63	3.62/1.81	800	4.57	180	275	55	66
DXHHI1.5-36-143TC	1.5	143TC	3485	230/460	84.0	0.84	3.91/1.96	1000	2.22	185	260	73	64
DXHHI1.5-18-145TC	1.5	145TC	1750	230/460	86.5	0.72	4.43/2.22	900	4.43	260	290	64	66
DXHHI1.5-12-182TC	1.5	182TC	1175	230/460	87.5	0.61	5.17/2.59	770	6.60	190	270	60	112
DXHHI2-36-145TC	2	145TC	3480	230/460	85.5	0.85	5.18/2.59	950	3.04	180	250	73	66
DXHHI2-18-145TC	2	145TC	1745	230/460	86.5	0.73	5.96/2.98	830	6.06	245	280	64	66
DXHHI2-12-184TC	2	184TC	1175	230/460	88.5	0.68	6.26/3.13	790	8.99	180	260	60	121
DXHHI3-36-182TC	3	182TC	3520	230/460	86.5	0.85	7.51/3.76	760	4.40	190	260	73	112
DXHHI3-18-182TC	3	182TC	1770	230/460	89.5	0.79	7.81/3.91	930	8.76	220	280	64	112
DXHHI3-12-213TC	3	213TC	1185	230/460	89.5	0.67	9.21/4.6	770	13.08	180	250	60	160
DXHHI5-36-184TC	5	184TC	3515	230/460	88.5	0.86	12.2/6.1	800	7.42	190	260	73	121
DXHHI5-18-184TC	5	184TC	1760	230/460	89.5	0.80	12.97/6.49	840	14.81	210	260	74	121
DXHHI5-12-215TC	5	215TC	1180	230/460	89.5	0.68	15.26/7.63	680	22.09	170	220	62	180
DXHHI7.5-36-213TC	7.5	213TC	3530	230/460	89.5	0.85	18.15/9.07	700	10.98	160	260	76	160
DXHHI7.5-18-213TC	7.5	213TC	1775	230/460	91.7	0.77	19.55/9.78	940	21.83	190	250	69	160
DXHHI7.5-12-254TC	7.5	254TC	1175	230/460	91.0	0.75	20.23/10.11	640	32.98	170	250	64	310
DXHHI10-36-215TC	10	215TC	3525</										

U.S Standard
LV NEMA Motor

HES Model - Severe duty, Premium Efficiency Three phase, TEFC, Foot mounted



Features

- Cast-iron terminal box
- Fully rotatable at 90 increments
- Main Terminal Box F1 ↔ F2 Field convertible

Foot Mounted NEMA Dimensions

Frame Size	Mounting & Overall										AD (Approx.)	HD (Approx.)	C (Approx.)	Shaft & Keyway					Conduit Box AA	Fig.
	D	2E	J	A	G	2F1	2F2	B	BA	H				U	N-W	R	S	ES		
143T	3.5	5.5	1.47	6.81	0.47	(5)	4	6.14	2.25	0.34	11.03	8.8	12.97	0.875	2.25	0.771	0.188	1.41	3/4"	A
145T	3.5	5.5	1.47	6.81	0.47	5	(4)	6.14	2.25	0.34	11.03	8.8	12.97	0.875	2.25	0.771	0.188	1.41	3/4"	
182T	4.5	7.5	1.64	8.65	0.6	(5.5)	4.5	6.69	2.75	0.41	12.79	10.73	15.59	1.125	2.75	0.986	0.25	1.78	3/4"	
184T	4.5	7.5	1.64	8.65	0.6	5.5	(4.5)	6.69	2.75	0.41	12.79	10.73	15.59	1.125	2.75	0.986	0.25	1.78	3/4"	
213T	5.25	8.5	1.69	9.88	0.66	5.5	-	6.69	3.5	0.41	14.56	12.32	18.31	1.375	3.38	1.201	0.312	2.41	1"	
215T	5.25	8.5	1.72	9.91	0.68	7	-	8.19	3.5	0.41	14.56	12.32	19.73	1.375	3.38	1.201	0.312	2.41	1"	
254T	6.25	10	2.13	11.69	0.72	8.25	-	9.57	4.25	0.53	18.43	14.75	23.54	1.625	4.00	1.416	0.375	2.91	1 1/4"	
256T	6.25	10	2.13	11.69	0.72	10	-	11.30	4.25	0.53	18.43	14.75	25.28	1.625	4.00	1.416	0.375	2.91	1 1/4"	
284TS	7	11	2.40	12.99	0.78	9.5	-	11.18	4.75	0.53	19.84	16.25	25.35	1.625	3.25	1.416	0.375	1.91	1 1/2"	
284T	7	11	2.40	12.99	0.78	9.5	-	11.18	4.75	0.53	19.84	16.25	26.72	1.875	4.62	1.591	0.5	3.28	1 1/2"	
286TS	7	11	2.40	12.99	0.78	11	-	12.68	4.75	0.53	19.84	16.25	27.28	1.625	3.25	1.416	0.375	1.91	1 1/2"	
286T	7	11	2.40	12.99	0.78	11	-	12.68	4.75	0.53	19.84	16.25	28.22	1.875	4.62	1.591	0.5	3.28	1 1/2"	
324TS	8	12.5	2.52	14.72	1.03	(12)	10.5	13.78	5.25	0.66	23.18	18.55	29.72	1.875	3.75	1.591	0.5	2.03	2"	
324T	8	12.5	2.52	14.72	1.03	(12)	10.5	13.78	5.25	0.66	23.18	18.55	31.22	2.125	5.25	1.845	0.5	3.91	2"	
326TS	8	12.5	2.52	14.72	1.03	12	(10.5)	13.78	5.25	0.66	23.18	18.55	29.72	1.875	3.75	1.591	0.5	2.03	2"	
326T	8	12.5	2.52	14.72	1.03	12	(10.5)	13.78	5.25	0.66	23.18	18.55	31.22	2.125	5.25	1.845	0.5	3.91	2"	

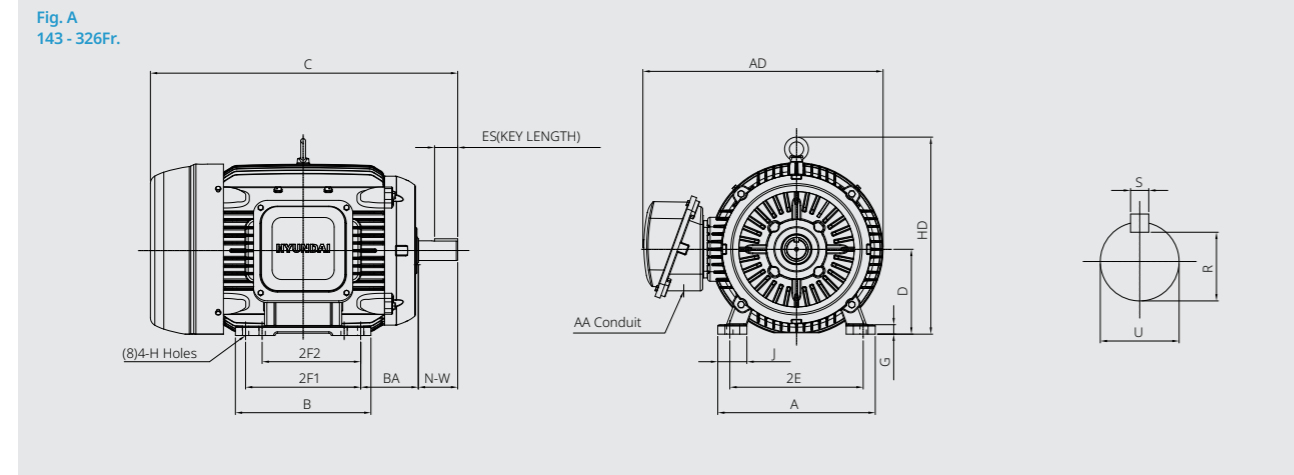

U.S Standard
LV NEMA Motor

HHI Model - Severe duty, Premium Efficiency Three phase, TEFC, Foot mounted



Features

- Cast-iron terminal box
- Fully rotatable at 90 increments
- Main Terminal Box F1 ↔ F2 Field convertible

Foot Mounted NEMA Dimensions

Frame Size	Mounting & Overall										AD (Approx.)	HD (Approx.)	C (Approx.)	Shaft & Keyway					Conduit Box AA	Fig.
	D	2E	J	A	G	2F1	2F2	B	BA	H				U	N-W	R	S	ES		
364TS	9	14	2.72	16.14	0.98	(12.25)	11.25	14.92	5.88	0.66	26.24	21.3	31.88	1.875	3.75	1.591	0.5	2.03	2 1/2"	A
364T	9	14	2.72	16.14	0.98	(12.25)	11.25	14.92	5.88	0.66	26.24	21.3	34.01	2.375	5.88	2.021	0.625	4.28	3"	
365TS	9	14	2.72	16.14	0.98	12.25	(11.25)	14.92	5.88	0.66	26.24	21.3	31.88	1.875	3.75	1.591	0.5	2.03	2 1/2"	
365T	9	14	2.72	16.14	0.98	12.25	(11.25)	14.92	5.88	0.66	26.24	21.3	34.01	2.375	5.88	2.021	0.625	4.28	3"	
404T	10	16	3.03	18.43	1.18	(13.75)	12.25	16.46	6.62	0.81	30.36	24.34	39.42	2.875	7.25	2.45	0.75	5.65	3"	
405TS	10	16	3.03	18.43	1.18	13.75	(12.25)	16.46	6.62	0.81	30.36	24.34	36.42	2.125	4.25	1.845	0.5	2.8	3"	
405T	10	16	3.03	18.43	1.18	13.75	(12.25)	16.46	6.62	0.81	30.36	24.34	39.42	2.875	7.25	2.45	0.75	5.65	3"	
444TS	11	18	3.07	20.51	1.42	(16.5)	14.5	19.21	7.5	0.81	32.46	27.52	41.46	2.375	4.75	2.021	0.625	3.03	3"	
444T	11	18	3.07	20.51	1.42	(16.5)	14.5	19.21	7.5	0.81	32.46	27.52	45.21	3.375	8.5	2.88	0.875	6.93	3"	
445TS	11	18	3.07	20.51	1.42	16.5	(14.5)	19.21	7.5	0.81	32.46	27.52	41.46	2.375	4.75	2.021	0.625	3.03	3"	
445T	11	18	3.07	20.51	1.42	16.5	(14.5)	19.21	7.5	0.81	32.46	27.52	45.21	3.375	8.5	2.88	0.875	6.93	3"	
447TS	11	18	3.07	20.51	1.42	20	(17.99)	22.72	7.5	0.81	32.46	27.52	44.96	2.375	4.75	2.021	0.625	3.03	3"	
447T	11	18	3.07	20.51	1.42	20	(17.99)	22.72	7.5	0.81	32.46	27.52	48.71	3.375	8.5	2.88	0.875	6.93	3"	
449TS	11	18	3.07	20.51	1.42	25	(20)	27.72	7.5	0.81	32.46	27.52	50.08	2.375	4.75	2.021	0.625	3.03	3"	
449T	11	18	3.07	20.51	1.42	25	(20)	27.72	7.5	0.81	32.46	27.52	53.83	3.375	8.5	2.88	0.875	6.93	3"	

Fig. A
364/5Fr.

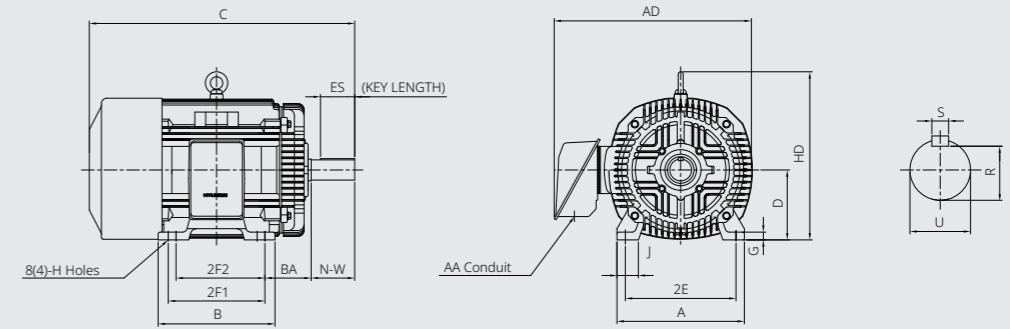
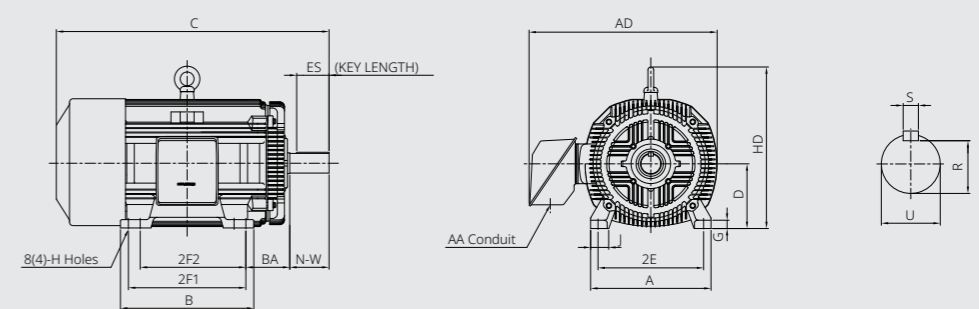

Fig. B
404 - 449Fr.



HSDE Model - Severe duty, Premium Efficiency, Large Motor Three phase, TEFC, Foot mounted



Features

- Cast-iron terminal box
- Fully rotatable at 90 increments
- Fabricated steel terminal box (Fr. 5812)

Foot Mounted NEMA Dimensions

Frame Size	Mounting & Overall										AD (Approx.)	HD (Approx.)	C (Approx.)	Shaft & Keyway					Conduit Box AA	Fig.
	D	2E	J	A	G	2F1	2F2	B	BA	H				U	N-W	R	S	ES		
L449TS	11	18	3.58	22.05	1.18	25	(20)	30.7	7.5	0.81	40.8	34.37	55.89	2.375	4.75	2.021	0.625	3.03	4"	A
L449T-4P	11	18	3.58	22.05	1.18	25	(20)	30.7	7.5	0.81	40.8	34.37	55.18	3.375	8.5	2.88	0.875	6.93	4"	
L449T-6P	11	18	3.58	22.05	1.18	25	(20)	30.7	7.5	0.81	40.8	34.37	59.98	3.375	8.5	2.88	0.875	6.93	4"	
5008S	12.5	20	4.88	25.04	1.26	(28)	25	33.07	8.5	0.94	42.01	36.3	62.03	2.625	5.75	2.275	0.625	4	4"	
5008	12.5	20	4.88	25.04	1.26	(28)	25	33.07	8.5	0.94	42.01	36.3	67.96	3.875	11.625	3.309	1	10	4"	
5009S	12.5	20	4.88	25.04	1.26	28	(25)	33.07	8.5	0.94	42.01	36.3	62.03	2.625	5.75	2.275	0.625	4	4"	
5009	12.5	20	4.88	25.04	1.26	28	(25)	33.07	8.5	0.94	42.01	36.3	67.96	3.875	11.625	3.309	1	10	4"	
5010S	12.5	20	4.88	25.04	1.26	(36)	32	41	8.5	0.94	42.01	36.3	67.54	2.625	5.75	2.275	0.625	4	4"	
5010	12.5	20	4.88	25.04	1.26	(36)	32	41	8.5	0.94	42.01	36.3	70.84	3.875	11.625	3.309	1	10	4"	
5011S	12.5	20	4.88	25.04	1.26	36	(32)	41	8.5	0.94	42.01	36.3	67.54	2.625	5.75	2.275	0.625	4	4"	
5011	12.5	20	4.88	25.04	1.26	36	(32)	41	8.5	0.94	42.01	36.3	70.84	3.875	11.625	3.309	1	10	4"	
5812S-2P	14.5	23	5.85	29.53	1.97	45	40	51.77	10	1.18	51.87	40.4	82.04	2.875	6.75	2.45	0.75	6.55	4"	B
5812-4P	14.5	23	5.85	29.53	1.97	45	40	51.77	10	1.18	51.87	40.4	83.6	4.375	8.3	3.817	1	8.05	4"	
5812-6P	14.5	23	5.85	29.53	1.97	45	40	51.77	10	1.18	51.87	40.4	83.6	4.375	8.3	3.817	1	8.05	4"	

Fig. A
L449 - 5011Fr.

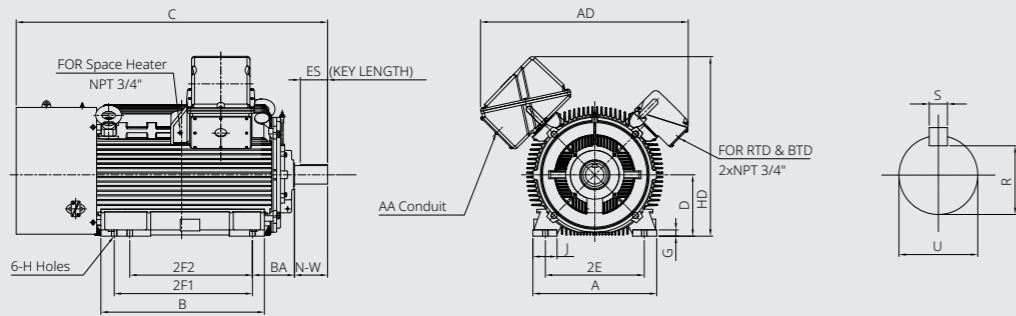
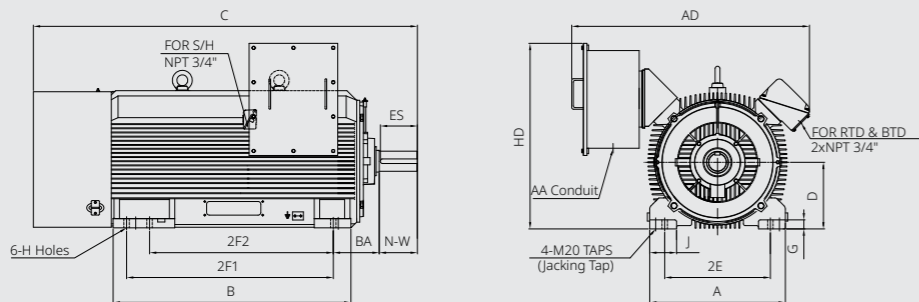

Fig. B
5812Fr.



HES Model - Severe duty, Premium Efficiency Three phase, TEFC, C-Face, Foot mounted



Features

- Cast-iron terminal box
- Fully rotatable at 90 increments
- Main Terminal Box F1 ↔ F2 Field convertible

C-Face, Foot Mounted NEMA Dimensions

Frame Size	Mounting & Overall										AD (Approx.)	HD (Approx.)	C (Approx.)	Conduit Box AA	Fig.
	D	2E	J	A	G	2F1	2F2	B	BA	H					
143TC	3.5	5.5	1.47	6.81	0.47	(5)	4	6.14	2.25	0.34	11.03	8.8	12.96	3/4"	A
145TC	3.5	5.5	1.47	6.81	0.47	5	(4)	6.14	2.25	0.34	11.03	8.8	12.96	3/4"	
182TC	4.5	7.5	1.64	8.65	0.6	(5.5)	4.5	6.69	2.75	0.41	12.79	10.73	15.59	3/4"	
184TC	4.5	7.5	1.64	8.65	0.6	5.5	(4.5)	6.69	2.75	0.41	12.79	10.73	15.59	3/4"	
213TC	5.25	8.5	1.72	9.91	0.68	5.5	-	6.69	3.5	0.41	14.56	12.32	18.31	1"	
215TC	5.25	8.5	1.72	9.91	0.68	7	-	8.19	3.5	0.41	14.56	12.32	19.73	1"	
254TC	6.25	10	2.13	11.69	0.72	8.25	-	9.57	4.25	0.53	18.43	14.75	23.54	1 1/4"	
256TC	6.25	10	2.13	11.69	0.72	10	-	11.30	4.25	0.53	18.43	14.75	25.27	1 1/4"	
284TSC	7	11	2.40	12.99	0.78	9.5	-	11.18	4.75	0.53	19.84	16.25	25.35	1 1/2"	
284TC	7	11	2.40	12.99	0.78	9.5	-	11.18	4.75	0.53	19.84	16.25	26.72	1 1/2"	
286TSC	7	11	2.40	12.99	0.78	11	-	12.68	4.75	0.53	19.84	16.25	26.84	1 1/2"	
286TC	7	11	2.40	12.99	0.78	11	-	12.68	4.75	0.53	19.84	16.25	28.21	1 1/2"	
324TSC	8	12.5	2.52	14.72	1.03	(12)	10.5	13.78	5.25	0.66	23.18	18.55	29.72	2"	
324TC	8	12.5	2.52	14.72	1.03	(12)	10.5	13.78	5.25	0.66	23.18	18.55	31.22	2"	
326TSC	8	12.5	2.52	14.72	1.03	12	(10.5)	13.78	5.25	0.66	23.18	18.55	29.72	2"	
326TC	8	12.5	2.52	14.72	1.03	12	(10.5)	13.78	5.25	0.66	23.18	18.55	31.22	2"	

Frame Size	C-Face							Shaft & Keyway					Fig.
	Aj	AK	BB	BC	BD	BF	n	DEPTH	U	N-W	R	S	
143TC	5.875	4.50	0.18	0.12	6.5	3/8-16	4	0.56	0.875	2.25	0.771	0.188	1.41
145TC	5.875	4.50	0.18	0.12	6.5	3/8-16	4	0.56	0.875	2.25	0.771	0.188	1.41
182TC	7.25	8.50	0.28	0.12	8.85	1/2-13	4	0.75	1.125	2.75	0.986	0.25	1.78
184TC	7.25	8.50	0.28	0.12	8.85	1/2-13	4	0.75	1.125	2.75	0.986	0.25	1.78
213TC	7.25	8.50	0.25	0.25	8.81	1/2-13	4	0.75	1.375	3.38	1.201	0.312	2.41
215TC	7.25	8.50	0.25	0.25	8.81	1/2-13	4	0.75	1.375	3.38	1.201	0.312	2.41
254TC	7.25	8.50	0.28	0.25	9.25	1/2-13	4	0.75	1.625	4.00	1.416	0.375	2.91
256TC	7.25	8.50	0.28	0.25	9.25	1/2-13	4	0.75	1.625	4.00	1.416	0.375	2.91
284TSC	9.0	10.50	0.28	0.25	11.02	1/2-13	4	0.75	1.625	3.25	1.416	0.375	1.91
284TC	9.0	10.50	0.28	0.25	11.02	1/2-13	4	0.75	1.875	4.62	1.591	0.5	3.28
286TSC	9.0	10.50	0.28	0.25	11.02	1/2-13	4	0.75	1.625	3.25	1.416	0.375	1.91
286TC	9.0	10.50	0.28	0.25	11.02	1/2-13	4	0.75	1.875	4.62	1.591	0.5	3.28
324TSC	11.0	12.50	0.28	0.25	12.99	5/8-11	4	0.94	1.875	3.75	1.591	0.5	2.03
324TC	11.0	12.50	0.28	0.25	12.99	5/8-11	4	0.94	2.125	5.25	1.845	0.5	3.91
326TSC	11.0	12.50	0.28	0.25	12.99	5/8-11	4	0.94	1.875	3.75	1.591	0.5	2.03
326TC	11.0	12.50	0.28	0.25	12.99	5/8-11	4	0.94	2.125	5.25	1.845	0.5	3.91

Fig. A
143 - 326Fr.

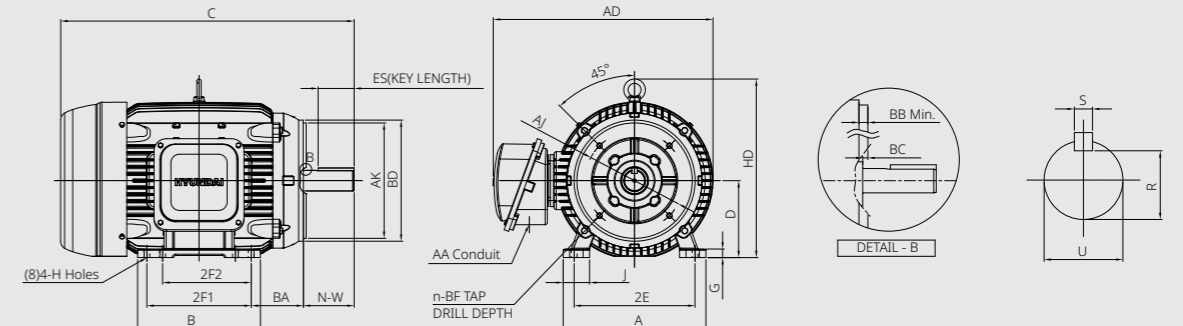

HHI Model - Severe duty, Premium Efficiency Three phase, TEFC, C-Face, Foot mounted



Features

- Cast-iron terminal box
- Fully rotatable at 90 increments
- Main Terminal Box F1 ↔ F2 Field convertible

C-Face, Foot Mounted NEMA Dimensions

Frame Size	Mounting & Overall										AD (Approx.)	HD (Approx.)	C (Approx.)	Conduit Box AA	Fig.
	D	2E	J	A	G	2F1	2F2	B	BA	H					
364TSC	9	14	2.72	16.14	0.98	(12.25)	11.25	14.92	5.88	0.66	26.01	36.25	31.88	3"	A
364TC	9	14	2.72	16.14	0.98	(12.25)	11.25	14.92	5.88	0.66	26.01	36.25	34.01	3"	
365TSC	9	14	2.72	16.14	0.98	(12.25)	14.92	5.88	0.66	26.01	36.25	31.88	3"		
365TC	9	14	2.72	16.14	0.98	(12.25)	14.92	5.88	0.66	26.01	36.25	34.01	3"		
404TC	10	16	3.03	18.43	1.18	(13.75)	12.25	16.46	6.62	0.81	30.13	40.48	39.42	3"	
405TSC	10	16	3.03	18.43	1.18	13.75	(12.25)	16.46	6.62	0.81	30.13	40.48	36.42	3"	
405TC	10	16	3.03	18.43	1.18	13.75	(12.25)	16.46	6.62	0.81	30.13	40.48	39.42	3"	
444TSC	11	18	3.07	20.51	1.42	(16.5)	14.5	19.21	7.5	0.81	32.48	45.63	41.46	3"	
444TC	11	18	3.07	20.51	1.42	(16.5)	14.5	19.21	7.5	0.81	32.48	45.63	45.21	3"	
445TSC	11	18	3.07	20.51	1.42	16.5	(14.5)	19.21	7.5	0.81	32.48	45.63	41.46	3"	
445TC	11	18	3.07	20.51	1.42	16.5	(14.5)	19.21	7.5	0.81	32.48	45.63	45.21	3"	
447TSC	11	18	3.07	20.51	1.42	20	(17.99)	22.72	7.5	0.81	32.48	45.63	44.96	3"	
447TC	11	18	3.07	20.51	1.42	20	(17.99)	22.72	7.5	0.81	32.48	45.63	48.71	3"	
449TSC	11	18	3.07	20.51	1.42	25	(20)	27.72	7.5	0.81	32.48	45.63	50.08	3"	
449TC	11	18	3.07	20.51	1.42	25	(20)	27.72	7.5	0.81	32.48	45.63	53.83	3"	

Frame Size	C-Face								Shaft & Keyway					Fig.
	AJ	AK	BB	BC	BD	BF	n	DEPTH	U	N-W	R	S	ES(Length)	
364TSC	11	12.5	0.25	0.25	13.54	5/8-11	8	0.94	1.875	3.75	1.591	0.5	2.03	A
364TC	11	12.5	0.25	0.25	13.54	5/8-11	8	0.94	2.375	5.88	2.021	0.625	4.28	
365TSC	11	12.5	0.25	0.25	13.54	5/8-11	8	0.94	1.875	3.75	1.591	0.5	2.03	
365TC	11	12.5	0.25	0.25	13.54	5/8-11	8	0.94	2.375	5.88	2.021	0.625	4.28	
404TC	11	12.5	0.25	0.25	13.94	5/8-11	8	0.94	2.875	7.25	2.45	0.75	5.65	
405TSC	11	12.5	0.25	0.25	13.94	5/8-11	8	0.94	2.125	4.25	1.845	0.5	2.8	
405TC	11	12.5	0.25	0.25	13.94	5/8-11	8	0.94	2.875	7.25	2.45	0.75	5.65	
444TSC	14	16	0.25	0.25	17.48	5/8-11	8	0.94	2.375	4.75	2.021	0.625	3.03	
444TC	14	16	0.25	0.25	17.48	5/8-11	8	0.94	3.375	8.5	2.88	0.875	6.93	
445TSC	14	16	0.25	0.25	17.48	5/8-11	8	0.94	2.375	4.75	2.021	0.625	3.03	
445TC	14	16	0.25	0.25	17.48	5/8-11	8	0.94	3.375	8.5	2.88	0.875	6.93	
447TSC	14	16	0.25	0.25	17.48	5/8-11	8	0.94	2.375	4.75	2.021	0.625	3.03	
447TC	14	16	0.25	0.25	17.48	5/8-11	8	0.94	3.375	8.5	2.88	0.875	6.93	
449TSC	14	16	0.25	0.25	17.48	5/8-11	8	0.94	2.375	4.75	2.021	0.625	3.03	
449TC	14	16	0.25	0.25	17.48	5/8-11	8	0.94	3.375	8.5	2.88	0.875	6.93	

Fig. A
364 - 449Fr.

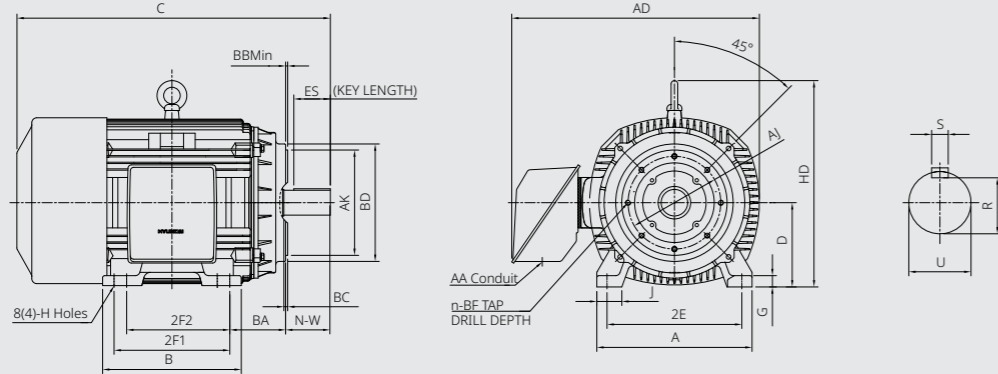

HSDE Model - Severe duty, Premium Efficiency, Large Motor Three phase, TEFC, C-Face, Foot mounted

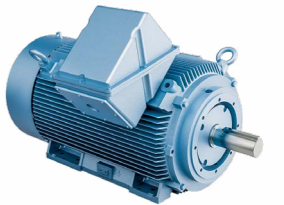

Features

- Cast-iron terminal box
- Fully rotatable at 90 increments
- Fabricated steel terminal box (Fr. 5812)

C-Face, Foot Mounted NEMA Dimensions

Frame Size	Mounting & Overall										AD (Approx.)	HD (Approx.)	C (Approx.)	Conduit Box AA	Fig.
	D	2E	J	A	G	2F1	2F2	B	BA	H					
L449TSC	11	18	3.58	22.05	1.18	25	(20)	30.7	7.5	0.81	40.8	34.37	55.89	4"	A
L449TC-4P	11	18	3.58	22.05	1.18	25	(20)	30.7	7.5	0.81	40.8	34.37	55.18	4"	
L449TC-6P	11	18	3.58	22.05	1.18	25	(20)	30.7	7.5	0.81	40.8	34.37	59.98	4"	
5008SC	12.5	20	4.88	25.04	1.26	(28)	25	33.07	8.5	0.94	42.01	36.3	62.03	4"	
5008C	12.5	20	4.88	25.04	1.26	(28)	25	33.07	8.5	0.94	42.01	36.3	67.96	4"	
5009SC	12.5	20	4.88	25.04	1.26	28	(25)	33.07	8.5	0.94	42.01	36.3	62.03	4"	
5009C	12.5	20	4.88	25.04	1.26	28	(25)	33.07	8.5	0.94	42.01	36.3	67.96	4"	
5010SC	12.5	20	4.88	25.04	1.26	(36)	32	41	8.5	0.94	42.01	36.3	67.54	4"	
5010C	12.5	20	4.88	25.04	1.26	(36)	32	41	8.5	0.94	42.01	36.3	70.84	4"	
5011SC	12.5	20	4.88	25.04	1.26	36	(32)	41	8.5	0.94	42.01	36.3	67.54	4"	
5011C	12.5	20	4.88	25.04	1.26	36	(32)	41	8.5	0.94	42.01	36.3	70.84	4"	

Frame Size	C-Face								Shaft & Keyway					Fig.
	AJ	AK	BB	BC	BD	BF	n	DEPTH	U	N-W	R	S	ES(Length)	
L449TSC	14	16	0.25	0.25	18	5/8-11	8	0.94	2.375	4.75	2.021	0.625	3.03	A
L449TC-4P	14	16	0.25	0.25	18	5/8-11	8	0.94	3.375	8.5	2.88	0.875	6.93	
L449TC-6P	14	16	0.25	0.25	18	5/8-11	8	0.94	3.375	8.5	2.88	0.875	6.93	
5008SC	14.5	16.5	0.25	0.25	19	5/8-11	8	0.94	2.625	5.75	2.275	0.625	4	
5008C	14.5	16.5	0.25	0.25	19	5/8-11	8	0.94	3.875	11.625	3.309	1	10	
5009SC	14.5	16.5	0.25	0.25	19	5/8-11	8	0.94	2.625	5.75	2.275	0.625	4	
5009C	14.5	16.5	0.25	0.25	19	5/8-11	8	0.94	3.875	11.625	3.309	1	10	
5010SC	14.5	16.5	0.25	0.25	19	5/8-11	8	0.94	2.625	5.75	2.275	0.625	4	
5010C	14.5	16.5	0.25	0.25	19	5/8-11	8	0.94	3.875	11.625	3.309	1	10	
5011SC	14.5	16.5	0.25	0.25	19	5/8-11	8	0.94	2.625	5.75	2.275	0.625	4	
5011C	14.5	16.5	0.25	0.25	19	5/8-11	8	0.94	3.875	11.625	3.309	1	10	

Fig. A
L449 - 5011Fr.

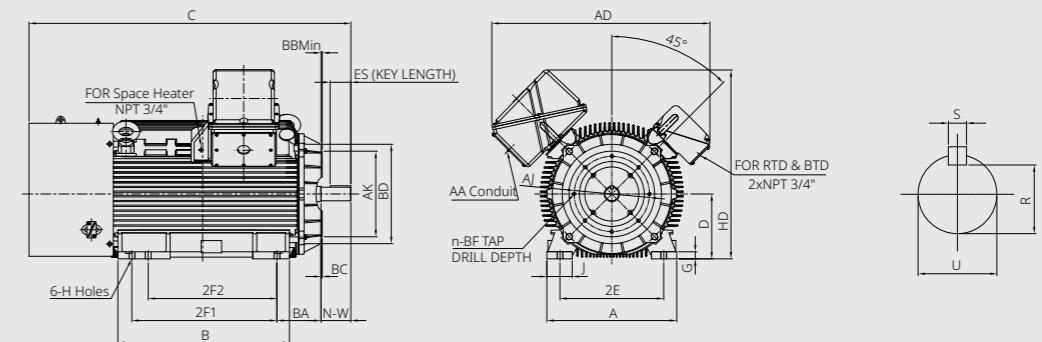

HES Model - Severe duty, Premium Efficiency Three phase, TEFC, D-Flange, Foot mounted



Features

- Cast-iron terminal box
- Fully rotatable at 90 increments
- Main Terminal Box F1 ↔ F2 Field convertible

D-Flange, Foot Mounted NEMA Dimensions

Frame Size	Mounting & Overall										AD (Approx.)	HD (Approx.)	C (Approx.)	Conduit Box AA	Fig.
	D	2E	J	A	G	2F1	2F2	B	BA	H					
143TD	3.5	5.5	1.49	6.88	0.48	(5)	4	6.14	2.25	0.34	12.46	11	12.96	3/4"	A
145TD	3.5	5.5	1.49	6.88	0.48	5	(4)	6.14	2.25	0.34	12.46	11	12.96	3/4"	
182TD	4.5	7.5	1.64	8.65	0.6	(5.5)	4.5	6.69	2.75	0.41	13.42	11.74	15.59	3/4"	
184TD	4.5	7.5	1.64	8.65	0.6	5.5	(4.5)	6.69	2.75	0.41	13.42	11.74	15.59	3/4"	
213TD	5.25	8.5	1.72	9.91	0.68	5.5	-	6.69	3.5	0.41	14.7	12.57	18.31	1"	
215TD	5.25	8.5	1.72	9.91	0.68	7	-	8.19	3.5	0.41	14.7	12.57	19.79	1"	
254TD	6.25	10	2.13	11.69	0.72	8.25	-	9.57	4.25	0.53	18.51	15.39	23.54	1 1/4"	
256TD	6.25	10	2.13	11.69	0.72	10	-	11.30	4.25	0.53	18.51	15.39	25.27	1 1/4"	
284TSD	7	11	2.40	12.99	0.78	9.5	-	11.18	4.75	0.53	19.84	16.51	25.35	1 1/2"	
284TD	7	11	2.40	12.99	0.78	9.5	-	11.18	4.75	0.53	19.84	16.51	26.72	1 1/2"	
286TSD	7	11	2.40	12.99	0.78	11	-	12.68	4.75	0.53	19.84	16.51	26.84	1 1/2"	
286TD	7	11	2.40	12.99	0.78	11	-	12.68	4.75	0.53	19.84	16.51	28.21	1 1/2"	
324TSD	8	12.5	2.52	14.72	1.03	(12)	10.5	13.78	5.25	0.66	24.14	19.41	29.72	2"	
324TD	8	12.5	2.52	14.72	1.03	(12)	10.5	13.78	5.25	0.66	24.14	19.41	31.22	2"	
326TSD	8	12.5	2.52	14.72	1.03	12	(10.5)	13.78	5.25	0.66	24.14	19.41	29.72	2"	
326TD	8	12.5	2.52	14.72	1.03	12	(10.5)	13.78	5.25	0.66	24.14	19.41	31.22	2"	

Frame Size	D-Flange					Shaft & Keyway							Fig.
	AJ	AK	BB	BD	BF	n	U	N-W	R	S	ES(Length)		
143TD	10.00	9.00	0.25	11	0.53	4	0.875	2.25	0.771	0.188	1.41	A	
145TD	10.00	9.00	0.25	11	0.53	4	0.875	2.25	0.771	0.188	1.41		
182TD	10.00	9.00	0.25	11	0.53	4	1.125	2.75	0.986	0.25	1.78		
184TD	10.00	9.00	0.25	11	0.53	4	1.125	2.75	0.986	0.25	1.78		
213TD	10.00	9.00	0.25	11	0.53	4	1.375	3.38	1.201	0.312	2.41		
215TD	10.00	9.00	0.25	11	0.53	4	1.375	3.38	1.201	0.312	2.41		
254TD	12.50	11.00	0.25	13.78	0.81	4	1.625	4.00	1.416	0.375	2.91		
256TD	12.50	11.00	0.25	13.78	0.81	4	1.625	4.00	1.416	0.375	2.91		
284TSD	12.50	11.00	0.25	13.78	0.81	4	1.625	3.25	1.416	0.375	1.91		
284TD	12.50	11.00	0.25	13.78	0.81	4	1.875	4.62	1.591	0.5	3.28		
286TSD	12.50	11.00	0.25	13.78	0.81	4	1.625	3.25	1.416	0.375	1.91		
286TD	12.50	11.00	0.25	13.78	0.81	4	1.875	4.62	1.591	0.5	3.28		
324TSD	16.00	14.00	0.25	17.72	0.81	4	1.875	3.75	1.591	0.5	2.03		
324TD	16.00	14.00	0.25	17.72	0.81	4	2.125	5.25	1.845	0.5	3.91		
326TSD	16.00	14.00	0.25	17.72	0.81	4	1.875	3.75	1.591	0.5	2.03		
326TD	16.00	14.00	0.25	17.72	0.81	4	2.125	5.25	1.845	0.5	3.91		

Fig. A
143 - 326Fr.

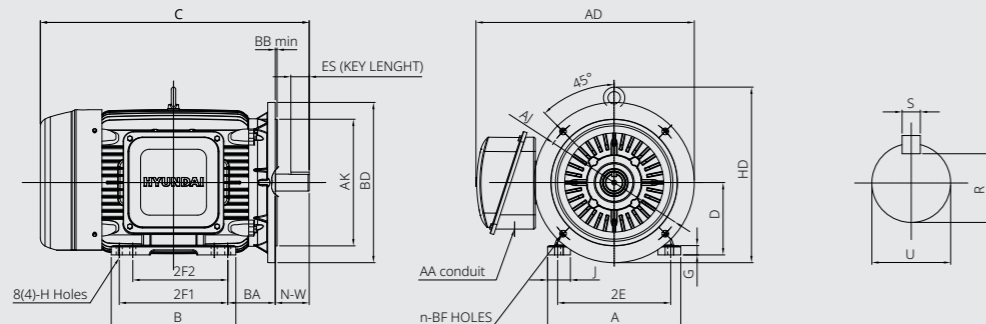

HHI Model - Severe duty, Premium Efficiency Three phase, TEFC, D-Flange, Foot mounted



Features

- Cast-iron terminal box
- Fully rotatable at 90 increments
- Main Terminal Box F1 ↔ F2 Field convertible

D-Flange, Foot Mounted NEMA Dimensions

Frame Size	Mounting & Overall										AD (Approx.)	HD (Approx.)	C (Approx.)	Conduit Box AA	Fig.
	D	2E	J	A	G	2F1	2F2	B	BA	H					
364TSD	9	14	2.72	16.14	0.98	(12.25)	11.25	14.92	5.88	0.66	26.01	36.25	31.88	3"	A
364TD	9	14	2.72	16.14	0.98	(12.25)	11.25	14.92	5.88	0.66	26.01	36.25	34.01	3"	
365TSD	9	14	2.72	16.14	0.98	12.25	(11.25)	14.92	5.88	0.66	26.01	36.25	31.88	3"	
365TD	9	14	2.72	16.14	0.98	12.25	(11.25)	14.92	5.88	0.66	26.01	36.25	34.01	3"	
404TD	10	16	3.03	18.43	1.18	(13.75)	12.25	16.46	6.62	0.81	30.13	40.48	39.42	3"	
405TSD	10	16	3.03	18.43	1.18	13.75	(12.25)	16.46	6.62	0.81	30.13	40.48	36.42	3"	
405TD	10	16	3.03	18.43	1.18	13.75	(12.25)	16.46	6.62	0.81	30.13	40.48	39.42	3"	
444TSD	11	18	3.07	20.51	1.42	(16.5)	14.5	19.21	7.5	0.81	32.48	45.63	41.46	3"	
444TD	11	18	3.07	20.51	1.42	(16.5)	14.5	19.21	7.5	0.81	32.48	45.63	45.21	3"	
445TSD	11	18	3.07	20.51	1.42	16.5	(14.5)	19.21	7.5	0.81	32.48	45.63	41.46	3"	
445TD	11	18	3.07	20.51	1.42	16.5	(14.5)	19.21	7.5	0.81	32.48	45.63	45.21	3"	
447TSD	11	18	3.07	20.51	1.42	20	(17.99)	22.72	7.5	0.81	32.48	45.63	44.96	3"	
447TD	11	18	3.07	20.51	1.42	20	(17.99)	22.72	7.5	0.81	32.48	45.63	48.71	3"	
449TSD	11	18	3.07	20.51	1.42	25	(20)	27.72	7.5	0.81	32.48	45.63	50.08	3"	
449TD	11	18	3.07	20.51	1.42	25	(20)	27.72	7.5	0.81	32.48	45.63	53.83	3"	

Frame Size	D-Flange						Shaft & Keyway					Fig.
	AJ	AK	BB	BD	BF	n	U	N-W	R	S	ES(Length)	
364TSD	16	14	0.25	17.99	0.81	8	1.875	3.75	1.591	0.5	2.03	A
364TD	16	14	0.25	17.99	0.81	8	2.375	5.88	2.021	0.625	4.28	
365TSD	16	14	0.25	17.99	0.81	8	1.875	3.75	1.591	0.5	2.03	
365TD	16	14	0.25	17.99	0.81	8	2.375	5.88	2.021	0.625	4.28	
404TD	20	18	0.25	21.65	0.81	8	2.875	7.25	2.45	0.75	5.65	
405TSD	20	18	0.25	21.65	0.81	8	2.125	4.25	1.845	0.5	2.8	
405TD	20	18	0.25	21.65	0.81	8	2.875	7.25	2.45	0.75	5.65	
444TSD	20	18	0.25	22	0.81	8	2.375	4.75	2.021	0.625	3.03	
444TD	20	18	0.25	22	0.81	8	3.375	8.5	2.88	0.875	6.93	
445TSD	20	18	0.25	22	0.81	8	2.375	4.75	2.021	0.625	3.03	
445TD	20	18	0.25	22	0.81	8	3.375	8.5	2.88	0.875	6.93	
447TSD	20	18	0.25	22	0.81	8	2.375	4.75	2.021	0.625	3.03	
447TD	20	18	0.25	22	0.81	8	3.375	8.5	2.88	0.875	6.93	
449TSD	20	18	0.25	22	0.81	8	2.375	4.75	2.021	0.625	3.03	
449TD	20	18	0.25	22	0.81	8	3.375	8.5	2.88	0.875	6.93	

Fig. A
364 - 449Fr.

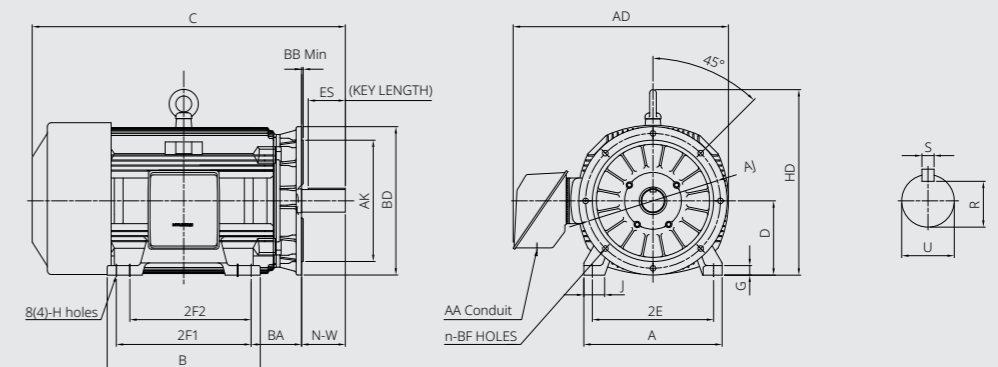

HES Model - Severe duty, Premium Efficiency Three phase, TEFC, C-Face, Footless



Features

- Cast-iron terminal box
- Fully rotatable at 90 increments
- Main Terminal Box F1 ↔ F2 Field convertible

C-Face, Footless NEMA Dimensions

Frame Size	C-Face									Overall			Conduit Box		Shaft & Keyway					Fig.
	AJ	AK	BB	BC	BD	BF	n	DEPTH	AD (Approx.)	HD (Approx.)	C (Approx.)	AA	U	N-W	R	S	ES(Length)			
143TCRD	5.875	4.50	0.18	0.12	6.50	3/8-16	4	0.56	11.03	9.30	12.96	3/4"	0.875	2.25	0.771	0.188	1.41	A		
145TCRD	5.875	4.50	0.18	0.12	6.50	3/8-16	4	0.56	11.03	9.30	12.96	3/4"	0.875	2.25	0.771	0.188	1.41			
182TCRD	7.25	8.50	0.28	0.12	8.85	1/2-13	4	0.75	12.79	11.15	15.59	3/4"	1.125	2.75	0.986	0.250	1.78			
184TCRD	7.25	8.50	0.28	0.12	8.85	1/2-13	4	0.75	12.79	11.15	15.59	3/4"	1.125	2.75	0.986	0.250	1.78			
213TCRD	7.25	8.50	0.25	0.25	8.81	1/2-13	4	0.75	14.56	12.09	18.31	1"	1.375	3.38	1.201	0.312	2.41			
215TCRD	7.25	8.50	0.25	0.25	8.81	1/2-13	4	0.75	14.56	12.09	19.73	1"	1.375	3.38	1.201	0.312	2.41			
254TCRD	7.25	8.50	0.28	0.25	9.25	1/2-13	4	0.75	18.43	14.67	23.54	1 1/4"	1.625	4.00	1.416	0.375	2.91			
256TCRD	7.25	8.50	0.28	0.25	9.25	1/2-13	4	0.75	18.43	14.67	25.27	1 1/4"	1.625	4.00	1.416	0.375	2.91			
284TSCRD	9.00	10.50	0.28	0.25	11.02	1/2-13	4	0.75	19.84	16.14	25.35	1 1/2"	1.625	3.25	1.416	0.375	1.91			
284TCRD	9.00	10.50	0.28	0.25	11.02	1/2-13	4	0.75	19.84	16.14	26.72	1 1/2"	1.875	4.62	1.591	0.500	3.28			
286TSCRD	9.00	10.50	0.28	0.25	11.02	1/2-13	4	0.75	19.84	16.14	26.84	1 1/2"	1.625	3.25	1.416	0.375	1.91			
286TCRD	9.00	10.50	0.28	0.25	11.02	1/2-13	4	0.75	19.84	16.14	28.21	1 1/2"	1.875	4.62	1.591	0.500	3.28			
324TSCRD	11.00	12.50	0.28	0.25	12.99	5/8-11	4	0.94	23.18	18.43	29.72	2"	1.875	3.75	1.591	0.500	2.03			
324TCRD	11.00	12.50	0.28	0.25	12.99	5/8-11	4	0.94	23.18	18.43	31.22	2"	2.125	5.25	1.845	0.500	3.91			
326TSCRD	11.00	12.50	0.28	0.25	12.99	5/8-11	4	0.94	23.18	18.43	29.72	2"	1.875	3.75	1.591	0.500	2.03			
326TCRD	11.00	12.50	0.28	0.25	12.99	5/8-11	4	0.94	23.18	18.43	31.22	2"	2.125	5.25	1.845	0.500	3.91			

Fig. A
140 - 326Fr.

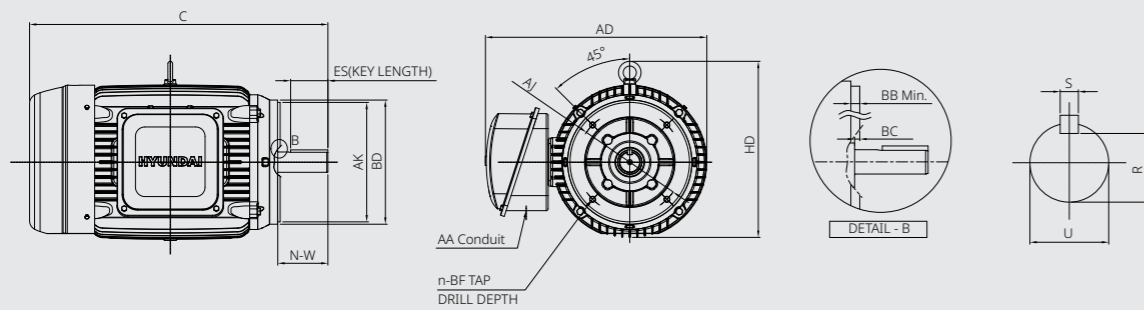

HHI Model - Severe duty, Premium Efficiency Three phase, TEFC, C-Face, Footless



Features

- Cast-iron terminal box
- Fully rotatable at 90 increments
- Main Terminal Box F1 ↔ F2 Field convertible

C-Face, Footless NEMA Dimensions

Frame Size	C-Face									Overall			Conduit Box		Shaft & Keyway					Fig.
	AJ	AK	BB	BC	BD	BF	n	DEPTH	AD (Approx.)	HD (Approx.)	C (Approx.)	AA	U	N-W	R	S	ES(Length)			
364TSCRD	11.00	12.50	0.25	0.25	13.54	5/8-11	8	0.94	26.01	24.89	31.88	3"	1.875	3.75	1.591	0.500	2.03	A		
364TCRD	11.00	12.50	0.25	0.25	13.54	5/8-11	8	0.94	26.01	24.89	34.01	3"	2.375	5.88	2.021	0.625	4.28			
365TSCRD	11.00	12.50	0.25	0.25	13.54	5/8-11	8	0.94	26.01	24.89	31.88	3"	1.875	3.75	1.591	0.500	2.03			
365TCRD	11.00	12.50	0.25	0.25	13.54	5/8-11	8	0.94	26.01	24.89	34.01	3"	2.375	5.88	2.021	0.625	4.28			
404TCRD	11.00	12.50	0.25	0.25	13.94	5/8-11	8	0.94	30.13	29.30	39.42	3"	2.875	7.25	2.450	0.750	5.65			
405TSCRD	11.00	12.50	0.25	0.25	13.94	5/8-11	8	0.94	30.13	29.30	36.42	3"	2.125	4.25	1.845	0.500	2.80			
405TCRD	11.00	12.50	0.25	0.25	13.94	5/8-11	8	0.94	30.13	29.30	39.42	3"	2.875	7.25	2.450	0.750	5.65			
444TSCRD	14.00	16.00	0.25	0.25	17.48	5/8-11	8	0.94	32.48	32.99	41.46	3"	2.375	4.75	2.021	0.625	3.03			
444TCRD	14.00	16.00	0.25	0.25	17.48	5/8-11	8	0.94	32.48	32.99	45.21	3"	3.375	8.50	2.880	0.875	6.93			
445TSCRD	14.00	16.00	0.25	0.25	17.48	5/8-11	8	0.94	32.48	32.99	41.46	3"	2.375	4.75	2.021	0.625	3.03			
445TCRD	14.00	16.00	0.25	0.25	17.48	5/8-11	8	0.94	32.48	32.99	45.21	3"	3.375	8.50	2.880	0.875	6.93			
447TSCRD	14.00	16.00	0.25	0.25	17.48	5/8-11	8	0.94	32.48	32.99	44.96	3"	2.375	4.75	2.021	0.625	3.03			
447TCRD	14.00	16.00	0.25	0.25	17.48	5/8-11	8	0.94	32.48	32.99	48.71	3"	3.375	8.50	2.880	0.875	6.93			
449TSCRD	14.00	16.00	0.25	0.25	17.48	5/8-11	8	0.94	32.48	32.99	50.08	3"	2.375	4.75	2.021	0.625	3.03			
449TCRD	14.00	16.00	0.25	0.25	17.48	5/8-11	8	0.94	32.48	32.99	53.83	3"	3.375	8.50	2.880	0.875	6.93			

Fig. A
364 - 449Fr.

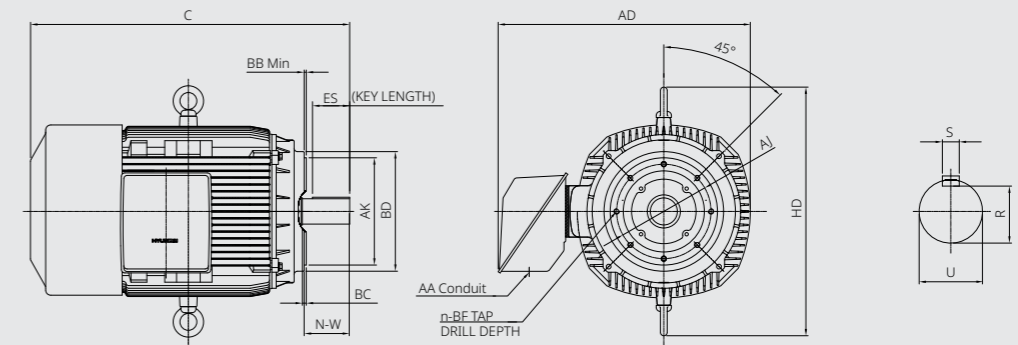

HES Model - Severe duty, Premium Efficiency Three phase, TEFC, D-Flange, Footless



Features

- Cast-iron terminal box
- Fully rotatable at 90 increments
- Main Terminal Box F1 ↔ F2 Field convertible

D-Flange, Footless NEMA Dimensions

Frame Size	D-Flange						Overall			Conduit Box	Shaft & Keyway					Fig.
	AJ	AK	BB	BD	BF	n	AD (Approx.)	HD (Approx.)	C (Approx.)	AA	U	N-W	R	S	ES(Length)	
143TDRD	10.00	9.00	0.25	11.00	0.53	4	12.46	11.00	12.96	3/4"	0.875	2.25	0.771	0.188	1.41	
145TDRD	10.00	9.00	0.25	11.00	0.53	4	12.46	11.00	12.96	3/4"	0.875	2.25	0.771	0.188	1.41	
182TDRD	10.00	9.00	0.25	11.00	0.53	4	13.42	11.74	15.59	3/4"	1.125	2.75	0.986	0.25	1.78	
184TDRD	10.00	9.00	0.25	11.00	0.53	4	13.42	11.74	15.59	3/4"	1.125	2.75	0.986	0.25	1.78	
213TDRD	10.00	9.00	0.25	11.00	0.53	4	14.70	12.57	18.31	1"	1.375	3.38	1.201	0.312	2.41	
215TDRD	10.00	9.00	0.25	11.00	0.53	4	14.70	12.57	19.79	1"	1.375	3.38	1.201	0.312	2.41	
254TDRD	12.50	11.00	0.25	13.78	0.81	4	18.51	15.39	23.54	1 1/4"	1.625	4.00	1.416	0.375	2.91	
256TDRD	12.50	11.00	0.25	13.78	0.81	4	18.51	15.39	25.27	1 1/4"	1.625	4.00	1.416	0.375	2.91	
284TSDRD	12.50	11.00	0.25	13.78	0.81	4	19.84	16.14	25.35	1 1/2"	1.625	3.25	1.416	0.375	1.91	
284TDRD	12.50	11.00	0.25	13.78	0.81	4	19.84	16.14	26.72	1 1/2"	1.875	4.62	1.591	0.5	3.28	
286TSDRD	12.50	11.00	0.25	13.78	0.81	4	19.84	16.14	26.84	1 1/2"	1.625	3.25	1.416	0.375	1.91	
286TDRD	12.50	11.00	0.25	13.78	0.81	4	19.84	16.14	28.21	1 1/2"	1.875	4.62	1.591	0.5	3.28	
324TSDRD	16.00	14.00	0.25	17.72	0.81	4	24.14	19.41	29.72	2"	1.875	3.75	1.591	0.5	2.03	
324TDRD	16.00	14.00	0.25	17.72	0.81	4	24.14	19.41	31.22	2"	2.125	5.25	1.845	0.5	3.91	
326TSDRD	16.00	14.00	0.25	17.72	0.81	4	24.14	19.41	29.72	2"	1.875	3.75	1.591	0.5	2.03	
326TDRD	16.00	14.00	0.25	17.72	0.81	4	24.14	19.41	31.22	2"	2.125	5.25	1.845	0.5	3.91	

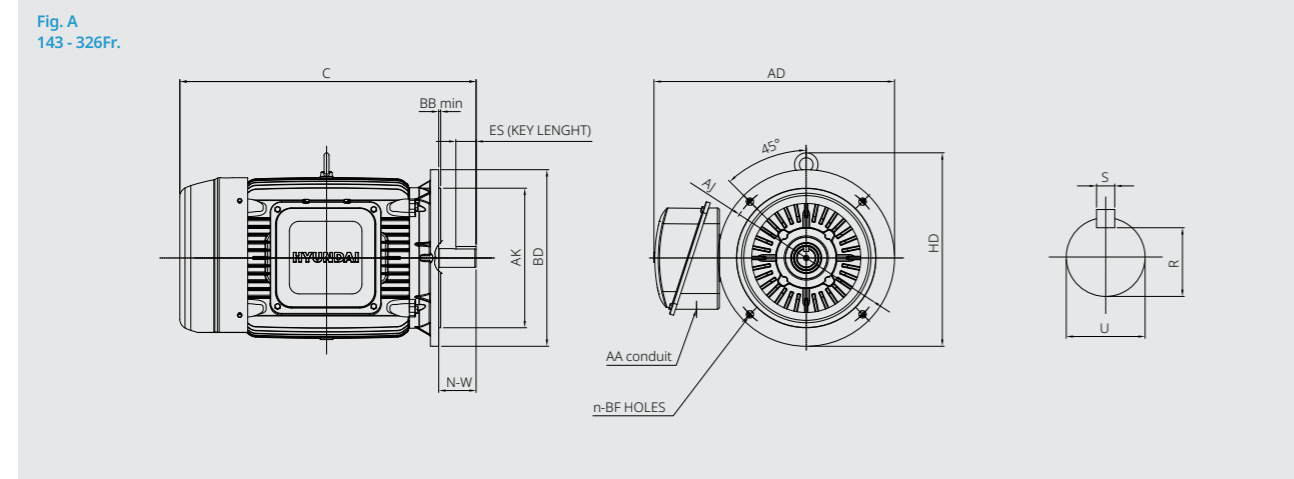

HHI Model - Severe duty, Premium Efficiency Three phase, TEFC, D-Flange, Footless



Features

- Cast-iron terminal box
- Fully rotatable at 90 increments
- Main Terminal Box F1 ↔ F2 Field convertible

D-Flange, Footless NEMA Dimensions

Frame Size	D-Flange						Overall			Conduit Box	Shaft & Keyway					Fig.
	AJ	AK	BB	BD	BF	n	AD (Approx.)	HD (Approx.)	C (Approx.)	AA	U	N-W	R	S	ES(Length)	
364TSDRD	16.00	14.00	0.25	17.99	0.81	8	26.01	24.89	31.88	3"	1.875	3.75	1.591	0.5	2.03	
364TDRD	16.00	14.00	0.25	17.99	0.81	8	26.01	24.89	34.01	3"	2.375	5.88	2.021	0.625	4.28	
365TSDRD	16.00	14.00	0.25	17.99	0.81	8	26.01	24.89	31.88	3"	1.875	3.75	1.591	0.5	2.03	
365TDRD	16.00	14.00	0.25	17.99	0.81	8	26.01	24.89	34.01	3"	2.375	5.88	2.021	0.625	4.28	
404TDRD	20.00	18.00	0.25	21.65	0.81	8	30.13	29.30	39.42	3"	2.875	7.25	2.450	0.75	5.65	
405TSDRD	20.00	18.00	0.25	21.65	0.81	8	30.13	29.30	36.42	3"	2.125	4.25	1.845	0.5	2.8	
405TDRD	20.00	18.00	0.25	21.65	0.81	8	30.13	29.30	39.42	3"	2.875	7.25	2.450	0.75	5.65	
444TSDRD	20.00	18.00	0.25	22.00	0.81	8	32.48	32.99	41.46	3"	2.375	4.75	2.021	0.625	3.03	
444TDRD	20.00	18.00	0.25	22.00	0.81	8	32.48	32.99	45.21	3"	3.375	8.50	2.880	0.875	6.93	
445TSDRD	20.00	18.00	0.25	22.00	0.81	8	32.48	32.99	41.46	3"	2.375	4.75	2.021	0.625	3.03	
445TDRD	20.00	18.00	0.25	22.00	0.81	8	32.48	32.99	45.21	3"	3.375	8.50	2.880	0.875	6.93	
447TSDRD	20.00	18.00	0.25	22.00	0.81	8	32.48	32.99	44.96	3"	2.375	4.75	2.021	0.625	3.03	
447TDRD	20.00	18.00	0.25	22.00	0.81	8	32.48	32.99	48.71	3"	3.375	8.50	2.880	0.875	6.93	
449TSDRD	20.00	18.00	0.25	22.00	0.81	8	32.48	32.99	50.08	3"	2.375	4.75	2.021	0.625	3.03	
449TDRD	20.00	18.00	0.25	22.00	0.81	8	32.48	32.99	53.83	3"	3.375	8.50	2.880	0.875	6.93	

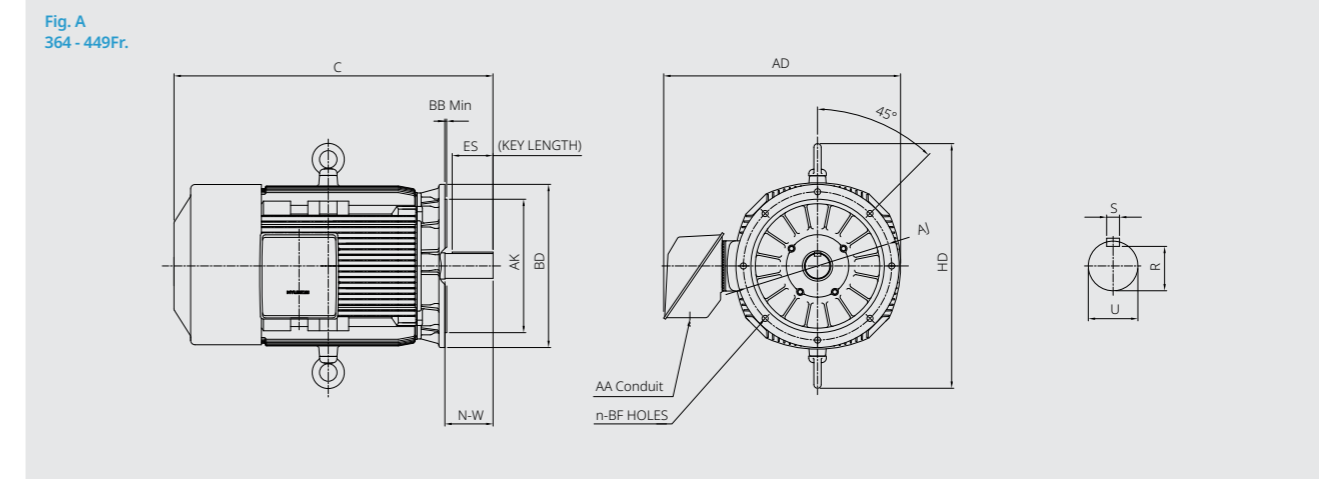

HES Model - Severe duty, Premium Efficiency Three phase, TEFC, Vertical, C-Face, Footless



Features

- Cast-iron terminal box
- Fully rotatable at 90 increments
- Main Terminal Box F1 ↔ F2 Field convertible

Vertical, C-Face, Footless NEMA Dimensions

Frame Size	C-Face								Overall			Conduit Box		Shaft & Keyway					Fig.
	AJ	AK	BB	BC	BD	BF	n	DEPTH	AD (Approx.)	HD (Approx.)	C (Approx.)	AA	U	N-W	R	S	ES(Length)		
143TCRDV	5.875	4.50	0.18	0.12	6.50	3/8-16	4	0.56	11.03	10.60	14.15	3/4"	0.875	2.25	0.771	0.188	1.41	A	
145TCRDV	5.875	4.50	0.18	0.12	6.50	3/8-16	4	0.56	11.03	10.60	14.15	3/4"	0.875	2.25	0.771	0.188	1.41		
182TCRDV	7.25	8.50	0.28	0.12	8.85	1/2-13	4	0.75	12.79	12.46	16.77	3/4"	1.125	2.75	0.986	0.250	1.78		
184TCRDV	7.25	8.50	0.28	0.12	8.85	1/2-13	4	0.75	12.79	12.46	16.77	3/4"	1.125	2.75	0.986	0.250	1.78		
213TCRDV	7.25	8.50	0.25	0.25	8.81	1/2-13	4	0.75	14.56	14.13	19.49	1"	1.375	3.38	1.201	0.312	2.41		
215TCRDV	7.25	8.50	0.25	0.25	8.81	1/2-13	4	0.75	14.56	14.13	20.97	1"	1.375	3.38	1.201	0.312	2.41		
254TCRDV	7.25	8.50	0.28	0.25	9.25	1/2-13	4	0.75	18.43	17.01	25.35	1 1/4"	1.625	4.00	1.416	0.375	2.91		
256TCRDV	7.25	8.50	0.28	0.25	9.25	1/2-13	4	0.75	18.43	17.01	27.08	1 1/4"	1.625	4.00	1.416	0.375	2.91		
284TCRDV	9.00	10.50	0.28	0.25	11.02	1/2-13	4	0.75	19.84	18.50	27.16	1 1/2"	1.625	3.25	1.416	0.375	1.91		
284TCRDV	9.00	10.50	0.28	0.25	11.02	1/2-13	4	0.75	19.84	18.50	28.53	1 1/2"	1.875	4.62	1.591	0.500	3.28		
286TCRDV	9.00	10.50	0.28	0.25	11.02	1/2-13	4	0.75	19.84	18.50	28.66	1 1/2"	1.625	3.25	1.416	0.375	1.91		
286TCRDV	9.00	10.50	0.28	0.25	11.02	1/2-13	4	0.75	19.84	18.50	30.03	1 1/2"	1.875	4.62	1.591	0.500	3.28		
324TCRDV	11.00	12.50	0.28	0.25	12.99	5/8-11	4	0.94	23.18	21.10	31.54	2"	1.875	3.75	1.591	0.500	2.03		
324TCRDV	11.00	12.50	0.28	0.25	12.99	5/8-11	4	0.94	23.18	21.10	33.04	2"	2.125	5.25	1.845	0.500	3.91		
326TCRDV	11.00	12.50	0.28	0.25	12.99	5/8-11	4	0.94	23.18	21.10	31.54	2"	1.875	3.75	1.591	0.500	2.03		
326TCRDV	11.00	12.50	0.28	0.25	12.99	5/8-11	4	0.94	23.18	21.10	33.04	2"	2.125	5.25	1.845	0.500	3.91		

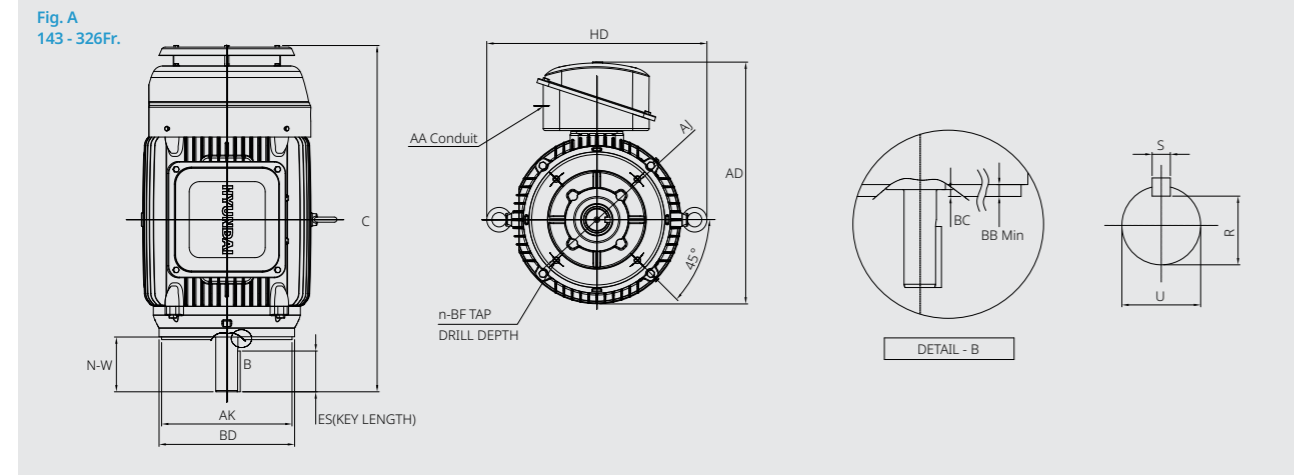

HHI Model - Severe duty, Premium Efficiency Three phase, TEFC, Vertical, C-Face, Footless



Features

- Cast-iron terminal box
- Fully rotatable at 90 increments
- Main Terminal Box F1 ↔ F2 Field convertible

Vertical, C-Face, Footless NEMA Dimensions

Frame Size	C-Face								Overall			Conduit Box		Shaft & Keyway					Fig.
	AJ	AK	BB	BC	BD	BF	n	DEPTH	AD (Approx.)	HD (Approx.)	C (Approx.)	AA	U	N-W	R	S	ES(Length)		
364TSCRDV	11.00	12.50	0.25	0.25	13.54	5/8-11	8	0.94	26.01	24.89	34.51	3"	1.875	3.75	1.591	0.500	2.03	A	
364TCRDV	11.00	12.50	0.25	0.25	13.54	5/8-11	8	0.94	26.01	24.89	36.63	3"	2.375	5.88	2.021	0.625	4.28		
365TSCRDV	11.00	12.50	0.25	0.25	13.54	5/8-11	8	0.94	26.01	24.89	34.51	3"	1.875	3.75	1.591	0.500	2.03		
365TCRDV	11.00	12.50	0.25	0.25	13.54	5/8-11	8	0.94	26.01	24.89	36.63	3"	2.375	5.88	2.021	0.625	4.28		
404TCRDV	11.00	12.50	0.25	0.25	13.94	5/8-11	8	0.94	30.13	29.30	42.03	3"	2.875	7.25	2.450	0.750	5.65		
405TSCRDV	11.00	12.50	0.25	0.25	13.94	5/8-11	8	0.94	30.13	29.30	39.03	3"	2.125	4.25	1.845	0.500	2.80		
405TCRDV	11.00	12.50	0.25	0.25	13.94	5/8-11	8	0.94	30.13	29.30	42.03	3"	2.875	7.25	2.450	0.750	5.65		
444TSCRDV	14.00	16.00	0.25	0.25	17.48	5/8-11	8	0.94	32.48	32.99	43.75	3"	2.375	4.75	2.021	0.625	3.03		
444TCRDV	14.00	16.00	0.25	0.25	17.48	5/8-11	8	0.94	32.48	32.99	46.49	3"	3.375	8.50	2.880	0.875	6.93		
445TSCRDV	14.00	16.00	0.25	0.25	17.48	5/8-11	8	0.94	32.48	32.99	43.75	3"	2.375	4.75	2.021	0.625	3.03		
445TCRDV	14.00	16.00	0.25	0.25	17.48	5/8-11	8	0.94	32.48	32.99	47.75	3"	3.375	8.50	2.880	0.875	6.93		
447TSCRDV	14.00	16.00	0.25	0.25	17.48	5/8-11	8	0.94	32.48	32.99	46.27	3"	2.375	4.75	2.021	0.625	3.03		
447TCRDV	14.00	16.00	0.25	0.25	17.48	5/8-11	8	0.94	32.48	32.99	51.25	3"	3.375	8.50	2.880	0.875	6.93		
449TSCRDV	14.00	16.00	0.25	0.25	17.48	5/8-11	8	0.94	32.48	32.99	52.37	3"	2.375	4.75	2.021	0.625	3.03		
449TCRDV	14.00	16.00	0.25	0.25	17.48	5/8-11	8	0.94	32.48	32.99	56.40	3"	3.375	8.50	2.880	0.875	6.93		

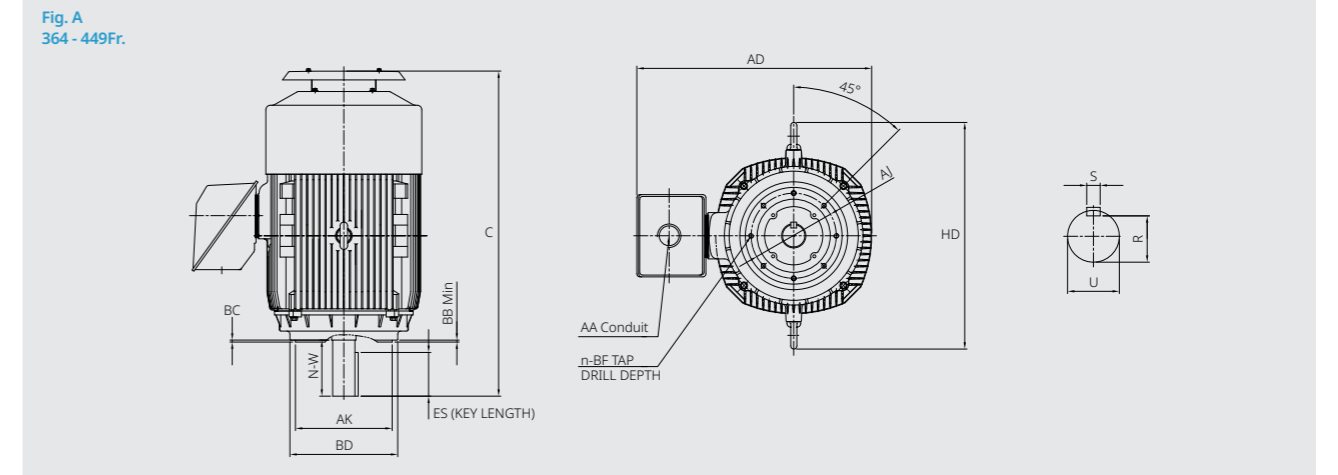

HES Model - Severe duty, Premium Efficiency Three phase, TEFC, Vertical, D-Flange, Footless



Features

- Cast-iron terminal box
- Fully rotatable at 90 increments
- Main Terminal Box F1 ↔ F2 Field convertible

Vertical, D-Flange, Footless NEMA Dimensions

Frame Size	D-Flange						Overall			Conduit Box	Shaft & Keyway					Fig.
	AJ	AK	BB	BD	BF	n	AD (Approx.)	HD (Approx.)	C (Approx.)	AA	U	N-W	R	S	ES(Length)	
143TDRDV	10.00	9.00	0.25	11.00	0.53	4	12.46	11.00	14.15	3/4"	0.875	2.25	0.771	0.188	1.41	
145TDRDV	10.00	9.00	0.25	11.00	0.53	4	12.46	11.00	14.15	3/4"	0.875	2.25	0.771	0.188	1.41	
182TDRDV	10.00	9.00	0.25	11.00	0.53	4	13.42	12.46	16.77	3/4"	1.125	2.75	0.986	0.25	1.78	
184TDRDV	10.00	9.00	0.25	11.00	0.53	4	13.42	12.46	16.77	3/4"	1.125	2.75	0.986	0.25	1.78	
213TDRDV	10.00	9.00	0.25	11.00	0.53	4	15.13	14.13	19.49	1"	1.375	3.38	1.201	0.312	2.41	
215TDRDV	10.00	9.00	0.25	11.00	0.53	4	15.13	14.13	20.97	1"	1.375	3.38	1.201	0.312	2.41	
254TDRDV	12.50	11.00	0.25	13.78	0.81	4	18.51	17.01	25.35	1 1/4"	1.625	4.00	1.416	0.375	2.91	
256TDRDV	12.50	11.00	0.25	13.78	0.81	4	18.51	17.01	27.08	1 1/4"	1.625	4.00	1.416	0.375	2.91	
284TSDRDV	12.50	11.00	0.25	13.78	0.81	4	19.84	18.50	27.16	1 1/2"	1.625	3.25	1.416	0.375	1.91	
284TDRDV	12.50	11.00	0.25	13.78	0.81	4	19.84	18.50	28.53	1 1/2"	1.875	4.62	1.591	0.5	3.28	
286TSDRDV	12.50	11.00	0.25	13.78	0.81	4	19.84	18.50	28.66	1 1/2"	1.625	3.25	1.416	0.375	1.91	
286TDRDV	12.50	11.00	0.25	13.78	0.81	4	19.84	18.50	30.03	1 1/2"	1.875	4.62	1.591	0.5	3.28	
324TSDRDV	16.00	14.00	0.25	17.72	0.81	4	24.14	21.10	31.54	2"	1.875	3.75	1.591	0.5	2.03	
324TDRDV	16.00	14.00	0.25	17.72	0.81	4	24.14	21.10	33.04	2"	2.125	5.25	1.845	0.5	3.91	
326TSDRDV	16.00	14.00	0.25	17.72	0.81	4	24.14	21.10	31.54	2"	1.875	3.75	1.591	0.5	2.03	
326TDRDV	16.00	14.00	0.25	17.72	0.81	4	24.14	21.10	33.04	2"	2.125	5.25	1.845	0.5	3.91	

A

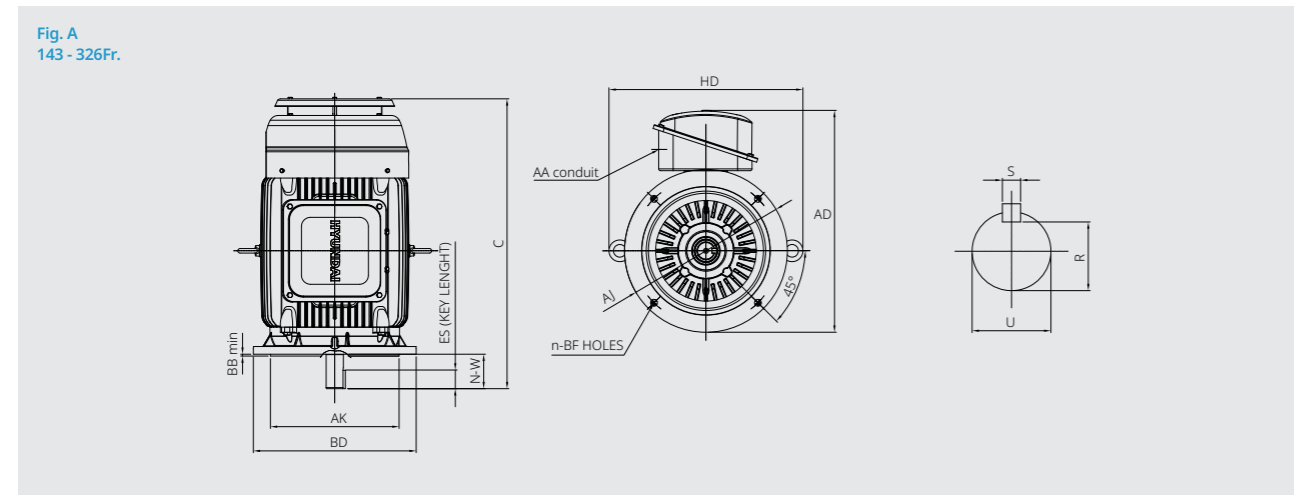

HHI Model - Severe duty, Premium Efficiency Three phase, TEFC, Vertical, D-Flange, Footless



Features

- Cast-iron terminal box
- Fully rotatable at 90 increments
- Main Terminal Box F1 ↔ F2 Field convertible

Vertical, D-Flange, Footless NEMA Dimensions

Frame Size	D-Flange						Overall			Conduit Box	Shaft & Keyway					Fig.
	AJ	AK	BB	BD	BF	n	AD (Approx.)	HD (Approx.)	C (Approx.)	AA	U	N-W	R	S	ES(Length)	
364TSDRDV	16.00	14.00	0.25	17.99	0.81	8	26.01	24.89	34.50	3"	1.875	3.75	1.591	0.5	2.03	
364TDRDV	16.00	14.00	0.25	17.99	0.81	8	26.01	24.89	36.62	3"	2.375	5.88	2.021	0.625	4.28	
365TSDRDV	16.00	14.00	0.25	17.99	0.81	8	26.01	24.89	34.50	3"	1.875	3.75	1.591	0.5	2.03	
365TDRDV	16.00	14.00	0.25	17.99	0.81	8	26.01	24.89	36.62	3"	2.375	5.88	2.021	0.625	4.28	
404TDRDV	20.00	18.00	0.25	21.65	0.81	8	30.13	29.30	42.02	3"	2.875	7.25	2.450	0.75	5.65	
405TSDRDV	20.00	18.00	0.25	21.65	0.81	8	30.13	29.30	39.02	3"	2.125	4.25	1.845	0.5	2.8	
405TDRDV	20.00	18.00	0.25	21.65	0.81	8	30.13	29.30	42.02	3"	2.875	7.25	2.450	0.75	5.65	
444TSDRDV	20.00	18.00	0.25	22.00	0.81	8	32.48	32.99	43.97	3"	2.375	4.75	2.021	0.625	3.03	
444TDRDV	20.00	18.00	0.25	22.00	0.81	8	32.48	32.99	47.72	3"	3.375	8.50	2.880	0.875	6.93	
445TSDRDV	20.00	18.00	0.25	22.00	0.81	8	32.48	32.99	43.97	3"	2.375	4.75	2.021	0.625	3.03	
445TDRDV	20.00	18.00	0.25	22.00	0.81	8	32.48	32.99	47.72	3"	3.375	8.50	2.880	0.875	6.93	
447TSDRDV	20.00	18.00	0.25	22.00	0.81	8	32.48	32.99	47.48	3"	2.375	4.75	2.021	0.625	3.03	
447TDRDV	20.00	18.00	0.25	22.00	0.81	8	32.48	32.99	51.23	3"	3.375	8.50	2.880	0.875	6.93	
449TSDRDV	20.00	18.00	0.25	22.00	0.81	8	32.48	32.99	52.60	3"	2.375	4.75	2.021	0.625	3.03	
449TDRDV	20.00	18.00	0.25	22.00	0.81	8	32.48	32.99	56.35	3"	3.375	8.50	2.880	0.875	6.93	

A

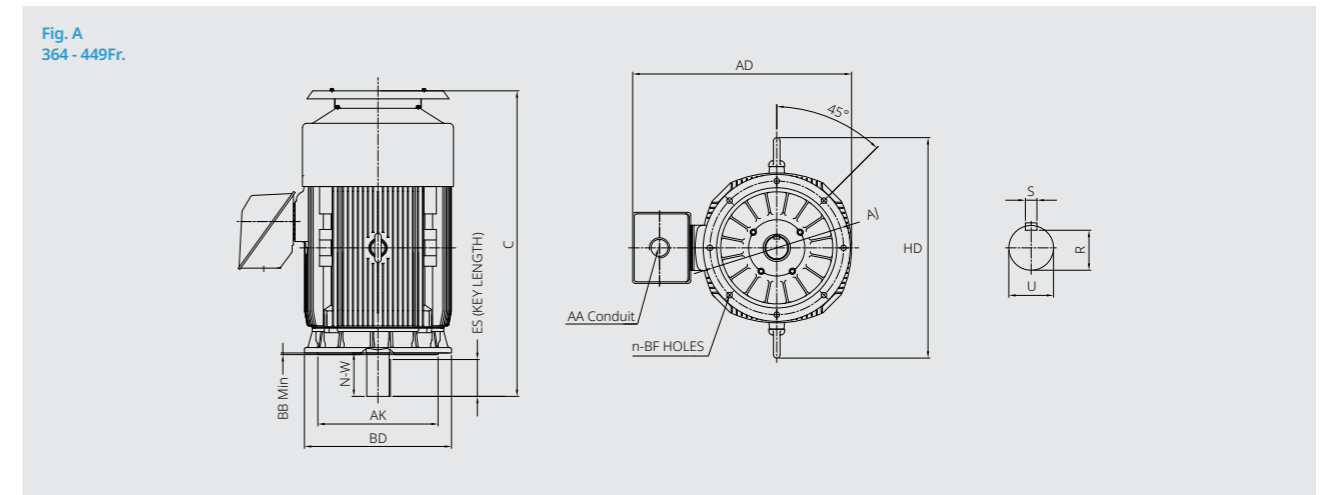

IEEE HL Model - IEEE841, Premium Efficiency Three phase, TEFC, Foot mounted



Features

- Cast-iron terminal box
- Fully rotatable at 90 increments
- Main Terminal Box F1 ↔ F2 Field convertible
- Protech seal

Foot Mounted NEMA Dimensions

Frame Size	Mounting & Overall										AD (Approx.)	HD (Approx.)	C (Approx.)	Shaft & Keyway					Conduit Box AA	Fig.
	D	2E	J	A	G	2F1	2F2	B	BA	H				U	N-W	R	S	ES		
143T	3.5	5.5	1.36	6.78	0.47	(5)	4	6.15	2.25	0.34	10.84	9.09	13.05	0.875	2.25	0.771	0.188	1.41	3/4"	A
145T	3.5	5.5	1.36	6.78	0.47	5	(4)	6.15	2.25	0.34	10.84	9.09	13.05	0.875	2.25	0.771	0.188	1.41	3/4"	A
182T	4.5	7.5	1.64	8.65	0.6	(5.5)	4.5	6.69	2.75	0.41	12.79	10.73	15.75	1.125	2.75	0.986	0.25	1.78	3/4"	B
184T	4.5	7.5	1.64	8.65	0.6	5.5	(4.5)	6.69	2.75	0.41	12.79	10.73	15.75	1.125	2.75	0.986	0.25	1.78	3/4"	B
213T	5.25	8.5	1.69	9.88	0.66	5.5	-	6.69	3.5	0.41	14.56	12.32	18.51	1.375	3.38	1.201	0.312	2.41	1"	B
215T	5.25	8.5	1.72	9.91	0.68	7	-	8.19	3.5	0.41	14.56	12.32	19.93	1.375	3.38	1.201	0.312	2.41	1"	B
254T	6.25	10	1.93	11.30	0.72	8.25	-	9.56	4.25	0.53	18.23	14.76	24.93	1.625	4.00	1.416	0.375	2.91	1 1/4"	C
256T	6.25	10	1.93	11.30	0.72	10	-	11.3	4.25	0.53	18.23	14.76	24.93	1.625	4.00	1.416	0.375	2.91	1 1/4"	C
284TS	7	11	2.20	12.60	0.78	9.5	-	11.18	4.75	0.53	19.54	16.29	24.65	1.625	3.25	1.416	0.375	1.91	1 1/2"	C
284T	7	11	2.20	12.60	0.78	9.5	-	11.18	4.75	0.53	19.54	16.29	26.02	1.875	4.62	1.591	0.5	3.28	1 1/2"	C
286TS	7	11	2.20	12.60	0.78	11	-	12.68	4.75	0.53	22.54	16.29	26.15	1.625	3.25	1.416	0.375	1.91	1 1/2"	C
286T	7	11	2.20	12.60	0.78	11	-	12.68	4.75	0.53	19.54	16.29	27.52	1.875	4.62	1.591	0.5	3.28	1 1/2"	C
324TS	8	12.5	2.36	14.33	1.11	(12)	10.5	13.78	5.25	0.66	24.23	18.60	29.96	1.875	3.75	1.591	0.5	2.03	2"	D
324T	8	12.5	2.36	14.33	1.11	(12)	10.5	13.78	5.25	0.66	24.23	18.60	31.46	2.125	5.25	1.845	0.5	3.91	2"	D
326TS	8	12.5	2.36	14.33	1.11	12	(10.5)	13.78	5.25	0.66	24.23	18.60	29.96	1.875	3.75	1.591	0.5	2.03	2"	D
326T	8	12.5	2.36	14.33	1.11	12	(10.5)	13.78	5.25	0.66	24.23	18.60	31.46	2.125	5.25	1.845	0.5	3.91	2"	D
364TS	9	14	2.72	16.14	0.98	(12.25)	11.25	14.92	5.88	0.66	26.25	21.30	33.06	1.875	3.75	1.591	0.5	2.03	3"	D
364T	9	14	2.72	16.14	0.98	(12.25)	11.25	14.92	5.88	0.66	26.25	21.30	35.20	2.375	5.88	2.021	0.625	4.28	3"	D
365TS	9	14	2.72	16.14	0.98	12.25	(11.25)	14.92	5.88	0.66	26.25	21.30	33.06	1.875	3.75	1.591	0.5	2.03	3"	D
365T	9	14	2.72	16.14	0.98	12.25	(11.25)	14.92	5.88	0.66	26.25	21.30	35.20	2.375	5.88	2.021	0.625	4.28	3"	D
404T	10	16	3.03	18.43	1.18	(13.75)	12.25	16.46	6.62	0.81	30.36	24.34	41.01	2.875	7.25	2.45	0.75	5.65	3"	D
405TS	10	16	3.03	18.43	1.18	13.75	(12.25)	16.46	6.62	0.81	30.36	24.34	38.00	2.125	4.25	1.845	0.5	2.8	3"	D
405T	10	16	3.03	18.43	1.18	13.75	(12.25)	16.46	6.62	0.81	30.36	24.34	41.01	2.875	7.25	2.45	0.75	5.65	3"	D
444TS	11	18	3.07	20.51	1.42	(16.5)	14.5	19.21	7.5	0.81	32.46	27.52	47.15	2.375	4.75	2.021	0.625	3.03	3"	D
444T	11	18	3.07	20.51	1.42	(16.5)	14.5	19.21	7.5	0.81	32.46	27.52	46.45	3.375	8.5	2.88	0.875	6.93	3"	D
445TS	11	18	3.07	20.51	1.42	16.5	(14.5)	19.21	7.5	0.81	32.46	27.52	47.15	2.375	4.75	2.021	0.625	3.03	3"	D
445T	11	18	3.07	20.51	1.42	16.5	(14.5)	19.21	7.5	0.81	32.46	27.52	46.78	3.375	8.5	2.88	0.875	6.93	3"	D
447TS	11	18	3.07	20.51	1.42	20	(17.99)	22.72	7.5	0.81	34.98	27.52	50.65	2.375	4.75	2.021	0.625	3.03	3"	D
447T	11	18	3.07	20.51	1.42	20	(17.99)	22.72	7.5	0.81	34.98	27.52	50.29	3.375	8.5	2.88	0.875	6.93	3"	D
449TS	11	18	3.07	20.51	1.42	25	(20)	27.72	7.5	0.81	34.98	27.52	55.77	2.375	4.75	2.021	0.625	3.03	3"	D
449T	11	18	3.07	20.51	1.42	25	(20)	27.72	7.5	0.81	34.98	27.52	53.83	3.375	8.5	2.88	0.875	6.93	3"	D

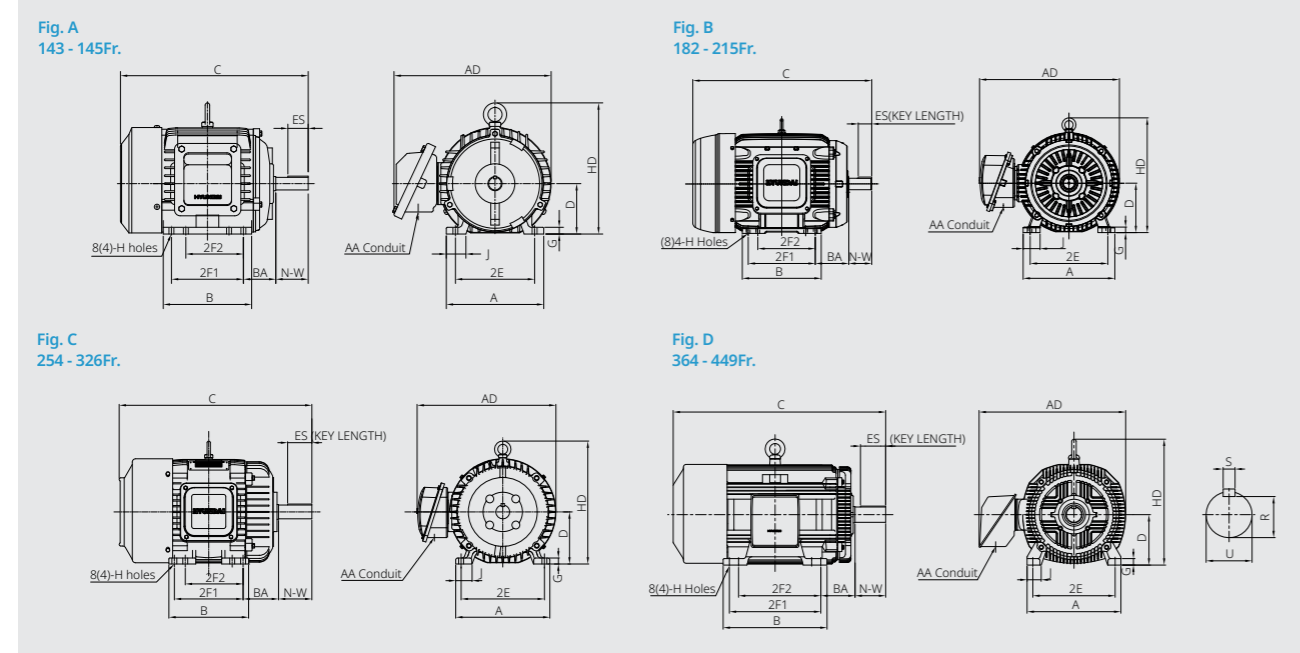

IEEE XL Model - IEEE841, Premium Efficiency, Large motor Three phase, TEFC, Foot mounted



Features

- Cast-iron terminal box
- Fully rotatable at 90 increments
- Fabricated steel terminal box (Fr. 5812)
- Labyrinth seal (at 3600 RPM Motor), Protech seal (at 1800, 1200 RPM Motor)

Foot Mounted NEMA Dimensions

Frame Size	Mounting & Overall										AD (Approx.)	HD (Approx.)	C (Approx.)	Shaft & Keyway					Conduit Box AA	Fig.
	D	2E	J	A	G	2F1	2F2	B	BA	H				U	N-W	R	S	ES		
L449TS	11	18	3.58	22.05	1.18	25	(20)	30.7	7.5	0.81	40.8	34.37	55.89	2.375	4.75	2.021	0.625	3.03	4"	A
L449T-4P	11	18	3.58	22.05	1.18	25	(20)	30.7	7.5	0.81	40.8	34.37	55.18	3.375	8.5	2.88	0.875	6.93	4"	A
L449T-6P	11	18	3.58	22.05	1.18	25	(20)	30.7	7.5	0.81	40.8	34.37	59.98	3.375	8.5	2.88	0.875	6.93	4"	A
5008S	12.5	20	4.88	25.04	1.26	(28)	25	33.07	8.5	0.94	42.01	36.3	62.03	2.625	5.75	2.275	0.625	4	4"	A
5008	12.5	20	4.88	25.04	1.26	(28)	25	33.07	8.5	0.94	42.01	36.3	67.96	3.875	11.625	3.309	1	10	4"	A
5009S	12.5	20	4.88	25.04	1.26	28	(25)	33.07	8.5	0.94	42.01	36.3	62.03	2.625	5.75	2.275	0.625	4	4"	A
5009	12.5	20	4.88	25.04	1.26	28	(25)	33.07	8.5	0.94	42.01	36.3	67.96	3.875	11.625	3.309	1	10	4"	A
5010S	12.5	20	4.88	25.04	1.26	(36)	32	41	8.5	0.94	42.01	36.3	67.54	2.625	5.75	2.275	0.625	4	4"	A
5010	12.5	20	4.88	25.04	1.26	(36)	32	41	8.5	0.94	42.01	36.3	70.84	3.875	11.625	3.309	1	10	4"	A
5011S	12.5	20	4.88	25.04	1.26	36	(32)	41	8.5	0.94	42.01	36.3	67.54	2.625	5.75	2.275	0.625	4	4"	A
5011	12.5	20	4.88	25.04	1.26	36	(32)	41	8.5	0.94	42.01	36.3	70.84	3.875	11.625	3.309	1	10	4"	A
5812S-2P	14.5	23	5.85	29.53	1.97	45	40	51.77	10	1.18	51.87	40.4	82.04	2.875	6.75	2.45	0.75	6.55	4"	B
5812-4P	14.5	23	5.85	29.53	1.97	45	40	51.77	10	1.18	51.87	40.4	83.6	4.375	8.3	3.817	1	8.05	4"	B
5812-6P	14.5	23	5.85	29.53	1.97	45	40	51.77	10	1.18	51.87	40.4	83.6	4.375	8.3	3.817	1	8.05	4"	B

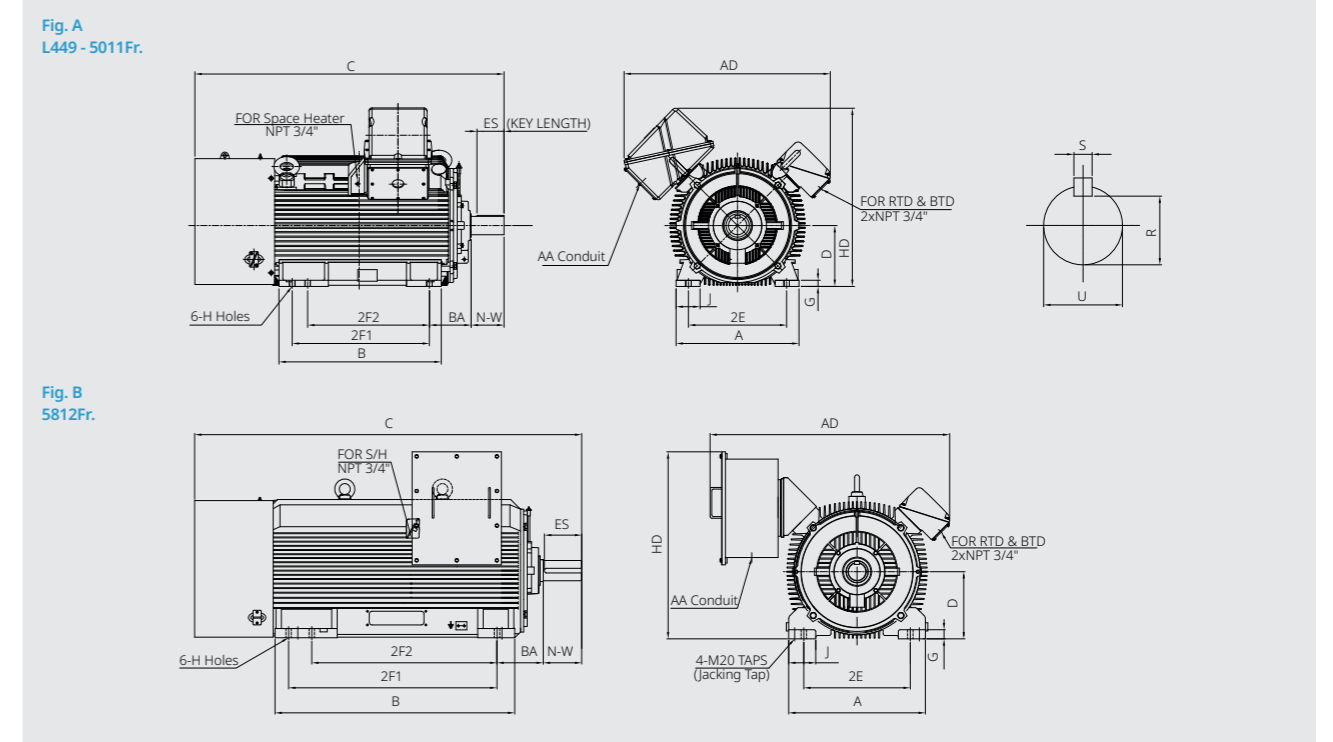

IEEE HL Model - IEEE841, Premium Efficiency Three phase, TEFC, C-Face, Foot mounted



Features

- Cast-iron terminal box
- Fully rotatable at 90 increments
- Main Terminal Box F1 ↔ F2 Field convertible
- Protech seal

C-Face, Foot Mounted NEMA Dimensions (Fr. 143 - 326)

Frame Size	Mounting & Overall										AD (Approx.)	HD (Approx.)	C (Approx.)	Conduit Box AA	Fig.
	D	2E	J	A	G	2F1	2F2	B	BA	H					
143TC	3.5	5.5	1.36	6.78	0.45	(5)	4	6.15	2.25	0.34	10.84	15.1	13.05	3/4"	A
145TC	3.5	5.5	1.36	6.78	0.47	5	(4)	6.15	2.25	0.34	10.84	15.1	13.05	3/4"	A
182TC	4.5	7.5	1.64	8.65	0.6	(5.5)	4.5	6.69	2.75	0.41	12.79	10.73	15.75	3/4"	B
184TC	4.5	7.5	1.64	8.65	0.6	5.5	(4.5)	6.69	2.75	0.41	12.79	10.73	15.75	3/4"	B
213TC	5.25	8.5	1.72	9.91	0.68	5.5	-	6.69	3.5	0.41	14.56	12.32	18.51	1"	B
215TC	5.25	8.5	1.72	9.91	0.68	7	-	8.19	3.5	0.41	14.56	12.32	19.93	1"	B
254TC	6.25	10	1.93	11.30	0.72	8.25	-	9.56	4.25	0.53	18.23	25.51	23.13	1 1/4"	C
256TC	6.25	10	1.93	11.30	0.72	10	-	11.3	4.25	0.53	18.23	25.51	24.86	1 1/4"	C
284TSC	7	11	2.20	12.60	0.78	9.5	-	11.18	4.75	0.53	19.535	28.47	24.65	1 1/2"	C
284TC	7	11	2.20	12.60	0.78	9.5	-	11.18	4.75	0.53	19.535	28.47	26.02	1 1/2"	C
286TSC	7	11	2.20	12.60	0.78	11	-	12.68	4.75	0.53	19.535	28.47	26.15	1 1/2"	C
286TC	7	11	2.20	12.60	0.78	11	-	12.68	4.75	0.53	19.535	28.47	27.52	1 1/2"	C
324TSC	8	12.5	2.44	14.33	1.11	(12)	10.5	13.78	5.25	0.66	23.23	32.03	29.96	2"	C
324TC	8	12.5	2.36	14.33	1.11	(12)	10.5	13.78	5.25	0.66	23.23	32.03	31.46	2"	C
326TSC	8	12.5	2.44	14.33	1.11	12	(10.5)	13.78	5.25	0.66	23.23	32.03	29.96	2"	C
326TC	8	12.5	2.36	14.33	1.11	12	(10.5)	13.78	5.25	0.66	23.23	32.03	31.46	2"	C

Frame Size	C-Face							Shaft & Keyway						Fig.
	AJ	AK	BB	BC	BD	BF	n	DEPTH	U	N-W	R	S	ES(Length)	
143TC	5.875	4.50	0.16	0.12	6.57	3/8-16	4	0.56	0.875	2.25	0.771	0.188	1.41	A
145TC	5.875	4.50	0.16	0.12	6.57	3/8-16	4	0.56	0.875	2.25	0.771	0.188	1.41	A
182TC	7.25	8.50	0.28	0.12	8.85	1/2-13	4	0.75	1.125	2.75	0.986	0.25	1.78	B
184TC	7.25	8.50	0.28	0.12	8.85	1/2-13	4	0.75	1.125	2.75	0.986	0.25	1.78	B
213TC	7.25	8.50	0.25	0.25	8.81	1/2-13	4	0.75	1.375	3.38	1.201	0.312	2.41	B
215TC	7.25	8.50	0.25	0.25	8.81	1/2-13	4	0.75	1.375	3.38	1.201	0.312	2.41	B
254TC	7.25	8.50	0.25	0.25	9.68	1/2-13	4	0.75	1.625	4.00	1.416	0.375	2.91	C
256TC	7.25	8.50	0.25	0.25	9.68	1/2-13	4	0.75	1.625	4.00	1.416	0.375	2.91	C
284TSC	9.0	10.50	0.25	0.25	10.9	1/2-13	4	0.75	1.625	3.25	1.416	0.375	1.91	C
284TC	9.0	10.50	0.25	0.25	10.9	1/2-13	4	0.75	1.875	4.62	1.591	0.5	3.28	C
286TSC	9.0	10.50	0.25	0.25	10.9	1/2-13	4	0.75	1.625	3.25	1.416	0.375	1.91	C
286TC	9.0	10.50	0.25	0.25	10.9	1/2-13	4	0.75	1.875	4.62	1.591	0.5	3.28	C
324TSC	11.0	12.50	0.25	0.25	13.27	5/8-11	4	0.94	1.875	3.75	1.591	0.5	2.03	C
324TC	11.0	12.50	0.25	0.25	13.27	5/8-11	4	0.94	2.125	5.25	1.845	0.5	3.91	C
326TSC	11.0	12.50	0.25	0.25	13.27	5/8-11	4	0.94	1.875	3.75	1.591	0.5	2.03	C
326TC	11.0	12.50	0.25	0.25	13.27	5/8-11	4	0.94	2.125	5.25	1.845	0.5	3.91	C

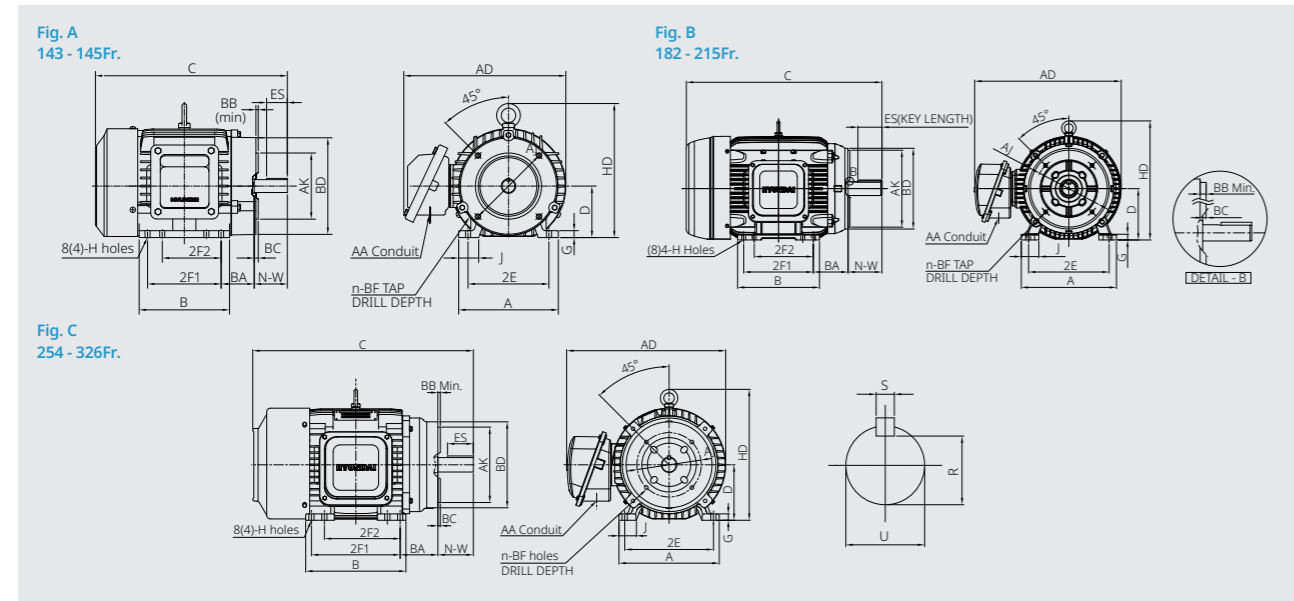

IEEE HL Model - IEEE841, Premium Efficiency Three phase, TEFC, C-Face, Foot mounted



Features

- Cast-iron terminal box
- Fully rotatable at 90 increments
- Main Terminal Box F1 ↔ F2 Field convertible
- Protech seal

C-Face, Foot Mounted NEMA Dimensions (Fr. 364 - 449)

Frame Size	Mounting & Overall										AD (Approx.)	HD (Approx.)	C (Approx.)	Conduit Box AA	Fig.
	D	2E	J	A	G	2F1	2F2	B	BA	H					
364TSC	9	14	2.72	16.14	0.98	(12.25)	11.25	14.92	5.88	0.66	26.01	36.25	33.06	3"	A
364TC	9	14	2.72	16.14	0.98	(12.25)	11.25	14.92	5.88	0.66	26.01	36.25	35.20	3"	A
365TSC	9	14	2.72	16.14	0.98	12.25	(11.25)	14.92	5.88	0.66	26.01	36.25	33.06	3"	A
365TC	9	14	2.72	16.14	0.98	12.25	(11.25)	14.92	5.88	0.66	26.01	36.25	35.20	3"	A
404TC	10	16	3.03	18.43	1.18	(13.75)	12.25	16.46	6.62	0.81	30.13	40.48	41.01	3"	A
405TSC	10	16	3.03	18.43	1.18	13.75	(12.25)	16.46	6.62	0.81	30.13	40.48	38.00	3"	A
405TC	10	16	3.03	18.43	1.18	13.75	(12.25)	16.46	6.62	0.81	30.13	40.48	41.01	3"	A
444TSC	11	18	3.07	20.51	1.42	(16.5)	14.5	19.21	7.5	0.81	32.48	45.63	47.15	3"	A
444TC	11	18	3.07	20.51	1.42	(16.5)	14.5	19.21	7.5	0.81	32.48	45.63	46.45	3"	A
445TSC	11	18	3.07	20.51	1.42	16.5	(14.5)	19.21	7.5	0.81	32.48	45.63	47.15	3"	A
445TC	11	18	3.07	20.51	1.42	16.5	(14.5)	19.21	7.5	0.81	32.48	45.63	46.78	3"	A
447TSC	11	18	3.07	20.51	1.42	20	(17.99)	22.72	7.5	0.81	35.00	45.63	50.65	3"	A
447TC	11	18	3.07	20.51	1.42	20	(17.99)	22.72	7.5	0.81	35.00	45.63	50.29	3"	A
449TSC	11	18	3.07	20.51	1.42	25	(20)	27.72	7.5	0.81	35.00	45.63	55.77	3"	A
449TC	11	18	3.07	20.51	1.42	25	(20)	27.72	7.5	0.81	35.00	45.63	53.83	3"	A

Frame Size	C-Face							Shaft & Keyway						Fig.
	AJ	AK	BB	BC	BD	BF	n	DEPTH	U	N-W	R	S	ES(Length)	
364TSC	11	12.5	0.25	0.25	13.54	5/8-11	8	0.94	1.875	3.75	1.591	0.5	2.03	A
364TC	11	12.5	0.25	0.25	13.54	5/8-11	8	0.94	2.375	5.88	2.021	0.625	4.28	A
365TSC	11	12.5	0.25	0.25	13.54	5/8-11	8	0.94	1.875	3.75	1.591	0.5	2.03	A
365TC	11	12.5	0.25	0.25	13.54	5/8-11	8	0.94	2.375	5.88	2.021	0.625	4.28	A
404TC	11	12.5	0.25	0.25	13.94	5/8-11	8	0.94	2.875	7.25	2.45	0.75	5.65	A
405TSC	11	12.5	0.25	0.25	13.94	5/8-11	8	0.94	2.125	4.25	1.845	0.5	2.8	A
405TC	11	12.5	0.25	0.25	13.94	5/8-11	8	0.94	2.875	7.25	2.45	0.75	5.65	A
444TSC	14	16	0.25	0.25	17.48	5/8-11	8	0.94	2.375	4.75	2.021	0.625	3.03	A
444TC	14	16	0.25	0.25	17.48	5/8-11	8	0.94	3.375	8.5	2.88	0.875	6.93	A
445TSC	14	16	0.25	0.25	17.48	5/8-11	8	0.94	2.375	4.75	2.021	0.625	3.03	A
445TC	14	16	0.25	0.25	17.48	5/8-11	8	0.94	3.375	8.5	2.88	0.875	6.93	A
447TSC	14	16	0.25	0.25	17.48	5/8-11	8	0.94	2.375	4.75	2.021	0.625	3.03	A
447TC	14	16	0.25	0.25	17.48	5/8-11	8	0.94	3.375	8.5	2.88	0.875	6.93	A
449TSC	14	16	0.25	0.25	17.48	5/8-11	8	0.94	2.375	4.75	2.021	0.625	3.03	A
449TC	14	16	0.25	0.25	17.48	5/8-11	8	0.94	3.375	8.5	2.88	0.875	6.93	A

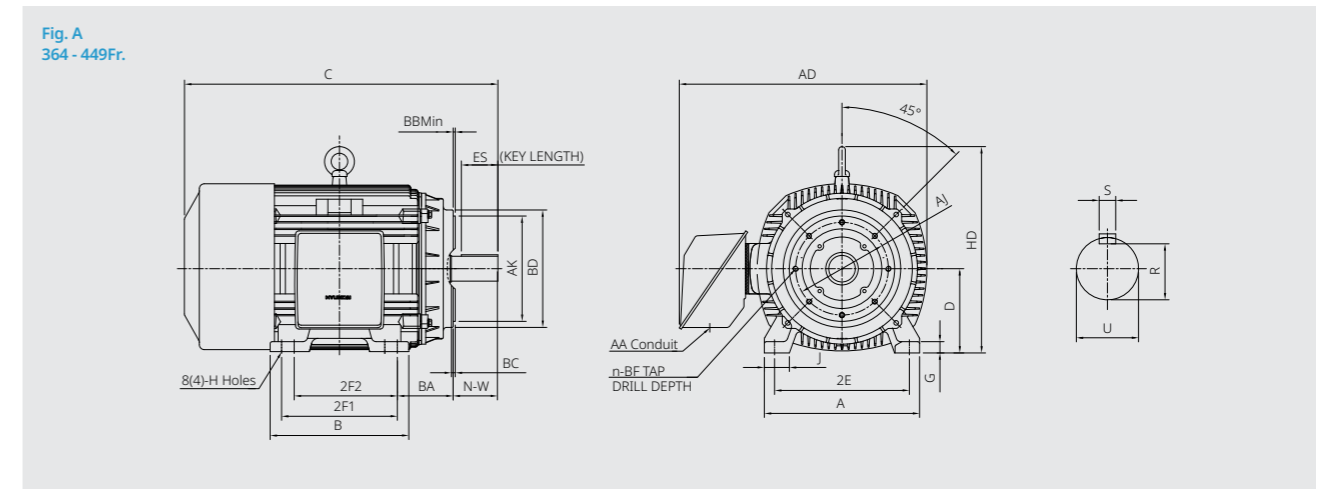

IEEE XL Model - IEEE841, Premium Efficiency, Large motor Three phase, TEFC, C-Face Foot mounted



Features

- Cast-iron terminal box
- Fully rotatable at 90 increments
- Fabricated steel terminal box (Fr. 5812)
- Labyrinth seal (at 3600 RPM Motor), Protech seal (at 1800, 1200 RPM Motor)

C-Face, Foot Mounted NEMA Dimensions

Frame Size	Mounting & Overall										AD (Approx.)	HD (Approx.)	C (Approx.)	Conduit Box AA	Fig.
	D	2E	J	A	G	2F1	2F2	B	BA	H					
L449TSC	11	18	3.58	22.05	1.18	25	(20)	30.7	7.5	0.81	40.8	34.37	55.89	4"	A
L449TC-4P	11	18	3.58	22.05	1.18	25	(20)	30.7	7.5	0.81	40.8	34.37	55.18	4"	
L449TC-6P	11	18	3.58	22.05	1.18	25	(20)	30.7	7.5	0.81	40.8	34.37	59.98	4"	
5008SC	12.5	20	4.88	25.04	1.26	(28)	25	33.07	8.5	0.94	42.01	36.3	62.03	4"	
5008C	12.5	20	4.88	25.04	1.26	(28)	25	33.07	8.5	0.94	42.01	36.3	67.96	4"	
5009SC	12.5	20	4.88	25.04	1.26	28	(25)	33.07	8.5	0.94	42.01	36.3	62.03	4"	
5009C	12.5	20	4.88	25.04	1.26	28	(25)	33.07	8.5	0.94	42.01	36.3	67.96	4"	
5010SC	12.5	20	4.88	25.04	1.26	(36)	32	41	8.5	0.94	42.01	36.3	67.54	4"	
5010C	12.5	20	4.88	25.04	1.26	(36)	32	41	8.5	0.94	42.01	36.3	70.84	4"	
5011SC	12.5	20	4.88	25.04	1.26	36	(32)	41	8.5	0.94	42.01	36.3	67.54	4"	
5011C	12.5	20	4.88	25.04	1.26	36	(32)	41	8.5	0.94	42.01	36.3	70.84	4"	

Frame Size	C-Face								Shaft & Keyway					Fig.
	AJ	AK	BB	BC	BD	BF	n	DEPTH	U	N-W	R	S	ES(Length)	
L449TSC	14	16	0.25	0.25	18	5/8-11	8	0.94	2.375	4.75	2.021	0.625	3.03	A
L449TC-4P	14	16	0.25	0.25	18	5/8-11	8	0.94	3.375	8.5	2.88	0.875	6.93	
L449TC-6P	14	16	0.25	0.25	18	5/8-11	8	0.94	3.375	8.5	2.88	0.875	6.93	
5008SC	14.5	16.5	0.25	0.25	19	5/8-11	8	0.94	2.625	5.75	2.275	0.625	4	
5008C	14.5	16.5	0.25	0.25	19	5/8-11	8	0.94	3.875	11.625	3.309	1	10	
5009SC	14.5	16.5	0.25	0.25	19	5/8-11	8	0.94	2.625	5.75	2.275	0.625	4	
5009C	14.5	16.5	0.25	0.25	19	5/8-11	8	0.94	3.875	11.625	3.309	1	10	
5010SC	14.5	16.5	0.25	0.25	19	5/8-11	8	0.94	2.625	5.75	2.275	0.625	4	
5010C	14.5	16.5	0.25	0.25	19	5/8-11	8	0.94	3.875	11.625	3.309	1	10	
5011SC	14.5	16.5	0.25	0.25	19	5/8-11	8	0.94	2.625	5.75	2.275	0.625	4	
5011C	14.5	16.5	0.25	0.25	19	5/8-11	8	0.94	3.875	11.625	3.309	1	10	

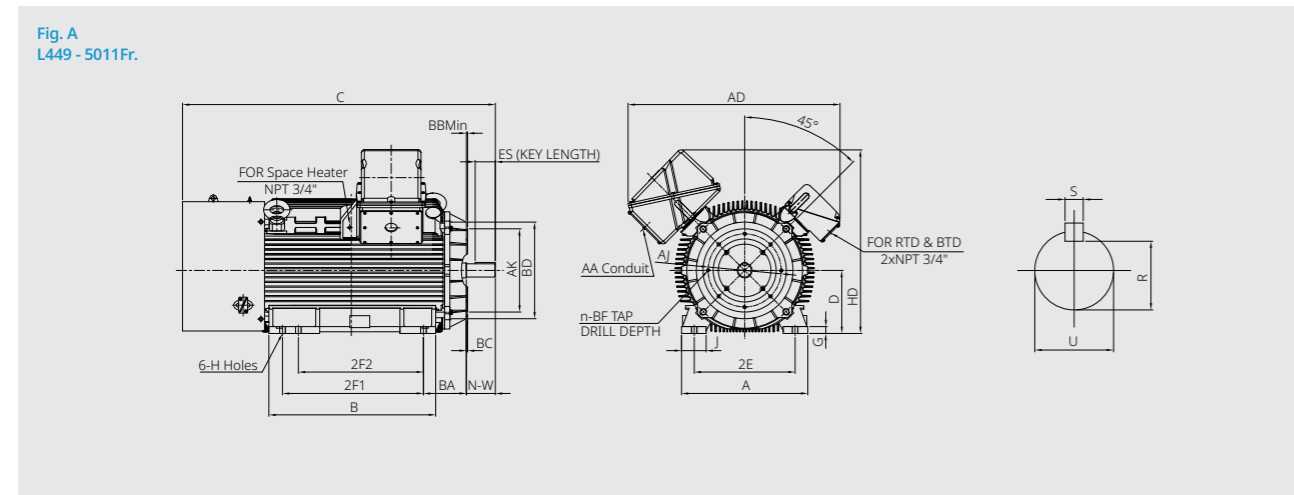

IEEE HL Model - IEEE841, Premium Efficiency Three phase, TEFC, D-Flange, Foot mounted



Features

- Cast-iron terminal box
- Fully rotatable at 90 increments
- Main Terminal Box F1 ↔ F2 Field convertible
- Protech seal

D-Flange, Foot Mounted NEMA Dimensions (Fr. 182 - 326)

Frame Size	Mounting & Overall										AD (Approx.)	HD (Approx.)	C (Approx.)	Conduit Box AA	Fig.
	D	2E	J	A	G	2F1	2F2	B	BA	H					
182TD	4.5	7.5	1.64	8.65	0.6	(5.5)	4.5	6.69	2.75	0.41	13.42	11.74	15.75	3/4"	A
184TD	4.5	7.5	1.64	8.65	0.6	5.5	(4.5)	6.69	2.75	0.41	13.42	11.74	15.75	3/4"	
213TD	5.25	8.5	1.72	9.91	0.68	5.5	-	6.69	3.5	0.41	14.7	12.57	18.51	1"	
215TD	5.25	8.5	1.72	9.91	0.68	7	-	8.19	3.5	0.41	14.7	12.57	19.99	1"	
254TD	6.25	10	1.93	11.30	0.72	8.25	-	9.56	4.25	0.53	18.85	14.76	23.2	1 1/4"	
256TD	6.25	10	1.93	11.30	0.72	10	-	11.30	4.25	0.53	18.85	14.76	24.93	1 1/4"	
284TSD	7	11	2.20	12.60	0.78	9.5	-	11.18	4.75	0.53	19.44	16.29	24.65	1 1/2"	
284TD	7	11	2.20	12.60	0.78	9.5	-	11.18	4.75	0.53	19.44	16.29	26.02	1 1/2"	
286TSD	7	11	2.20	12.60	0.78	11	-	12.68	4.75	0.53	19.44	16.29	26.22	1 1/2"	
286TD	7	11	2.20	12.60	0.78	11	-	12.68	4.75	0.53	19.44	16.29	26.52	1 1/2"	
324TSD	8	12.5	2.36	14.33	1.11	(12)	10.5	13.78	5.25	0.66	24.31	18.60	29.96	2"	B
324TD	8	12.5	2.36	14.33	1.11	(12)	10.5	13.78	5.25	0.66	24.31	18.60	31.46	2"	
326TSD	8	12.5	2.36	14.33	1.11	12	(10.5)	13.78	5.25	0.66	24.31	18.60	29.96	2"	
326TD	8	12.5	2.36	14.33	1.11	12	(10.5)	13.78	5.25	0.66	24.31	18.60	31.46	2"	

Frame Size	D-Flange						Shaft & Keyway					Fig.
	AJ	AK	BB	BD	BF	n	U	N-W	R	S	ES(Length)	
182TD	10.00	9.00	0.25	11	0.53	4	1.125	2.75	0.986	0.25	1.78	A
184TD	10.00	9.00	0.25	11	0.53	4	1.125	2.75	0.986	0.25	1.78	
213TD	10.00	9.00	0.25	11	0.53	4	1.375	3.38	1.201	0.312	2.41	
215TD	10.00	9.00	0.25	11	0.53	4	1.375	3.38	1.201	0.312	2.41	
254TD	12.50	11.00	0.25	14	0.81	4	1.625	4.00	1.416	0.375	2.91	
256TD	12.50	11.00	0.25	14	0.81	4	1.625	4.00	1.416	0.375	2.91	
284TSD	12.50	11.00	0.25	14	0.81	4	1.625	3.25	1.416	0.375	1.91	
284TD	12.50	11.00	0.25	14	0.81	4	1.875	4.62	1.591	0.5	3.28	
286TSD	12.50	11.00	0.25	14	0.81	4	1.625	3.25	1.416	0.375	1.91	
286TD	12.50	11.00	0.25	14	0.81	4	1.875	4.62	1.591	0.5	3.28	
324TSD	16.00	14.00	0.25	18	0.81	4	1.875	3.75	1.591	0.5	2.03	B
324TD	16.00	14.00	0.25	18	0.81	4	2.125	5.25	1.845	0.5	3.91	
326TSD	16.00	14.00	0.25	18	0.81	4	1.875	3.75	1.591	0.5	2.03	
326TD	16.00	14.00	0.25	18	0.81	4	2.125	5.25	1.845	0.5	3.91	

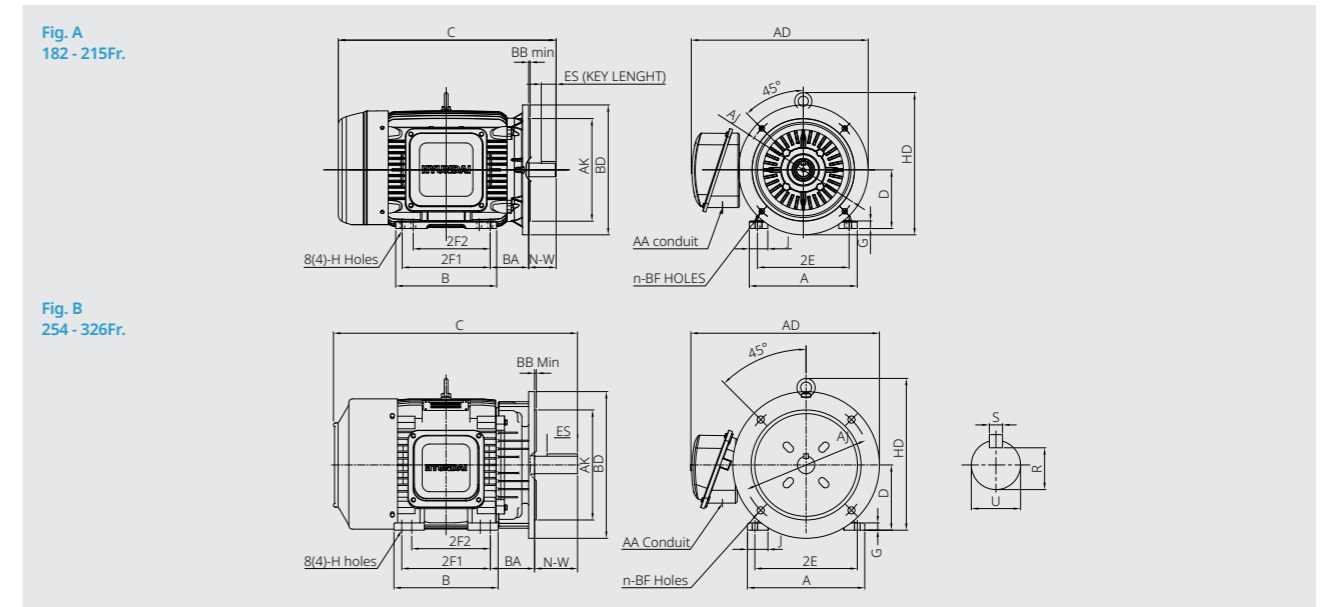

IEEE HL Model - IEEE841, Premium Efficiency Three phase, TEFC, D-Flange, Foot mounted



Features

- Cast-iron terminal box
- Fully rotatable at 90 increments
- Main Terminal Box F1 ↔ F2 Field convertible
- Protech seal

D-Flange, Foot Mounted NEMA Dimensions (Fr. 364 - 449)

Frame Size	Mounting & Overall										AD (Approx.)	HD (Approx.)	C (Approx.)	Conduit Box AA	Fig.	
	D	2E	J	A	G	2F1	2F2	B	BA	H						
364TSD	9	14	2.72	16.14	0.98	(12.25)	11.25	14.92	5.88	0.66	26.13	21.3	33.06	3"	A	
364TD	9	14	2.72	16.14	0.98	(12.25)	11.25	14.92	5.88	0.66	26.13	21.3	35.20	3"		
365TSD	9	14	2.72	16.14	0.98	(11.25)	14.92	5.88	0.66	26.13	21.3	33.06	3"	B		
365TD	9	14	2.72	16.14	0.98	(11.25)	14.92	5.88	0.66	26.13	21.3	35.20	3"			
404TD	10	16	3.03	18.43	1.18	(13.75)	12.25	16.46	6.62	0.81	31.11	24.34	41.01			3"
405TSD	10	16	3.03	18.43	1.18	13.75	(12.25)	16.46	6.62	0.81	31.11	24.34	38.00			3"
405TD	10	16	3.03	18.43	1.18	13.75	(12.25)	16.46	6.62	0.81	31.11	24.34	41.01			3"
444TSD	11	18	3.07	20.51	1.42	(16.5)	14.5	19.21	7.5	0.81	32.48	27.52	47.15			3"
444TD	11	18	3.07	20.51	1.42	(16.5)	14.5	19.21	7.5	0.81	32.48	27.52	46.45			3"
445TSD	11	18	3.07	20.51	1.42	16.5	(14.5)	19.21	7.5	0.81	32.48	27.52	47.15			3"
445TD	11	18	3.07	20.51	1.42	16.5	(14.5)	19.21	7.5	0.81	32.48	27.52	46.78		3"	
447TSD	11	18	3.07	20.51	1.42	20	(17.99)	22.72	7.5	0.81	32.48	27.52	50.65		3"	
447TD	11	18	3.07	20.51	1.42	20	(17.99)	22.72	7.5	0.81	32.48	27.52	50.29	3"		
449TSD	11	18	3.07	20.51	1.42	25	(20)	22.72	7.5	0.81	32.48	27.52	55.77	3"		
449TD	11	18	3.07	20.51	1.42	25	(20)	22.72	7.5	0.81	32.48	27.52	53.83	3"		

Frame Size	D-Flange						Shaft & Keyway						Fig.
	AJ	AK	BB	BD	BF	n	U	N-W	R	S	ES(Length)		
364TSD	16	14	0.25	17.99	0.81	8	1.875	3.75	1.591	0.5	2.03	A	
364TD	16	14	0.25	17.99	0.81	8	2.375	5.88	2.021	0.625	4.28		
365TSD	16	14	0.25	17.99	0.81	8	1.875	3.75	1.591	0.5	2.03		
365TD	16	14	0.25	17.99	0.81	8	2.375	5.88	2.021	0.625	4.28		
404TD	20	18	0.25	21.65	0.81	8	2.875	7.25	2.45	0.75	5.65		
405TSD	20	18	0.25	21.65	0.81	8	2.125	4.25	1.845	0.5	2.8		
405TD	20	18	0.25	21.65	0.81	8	2.875	7.25	2.45	0.75	5.65		
444TSD	20	18	0.25	22	0.81	8	2.375	4.75	2.021	0.625	3.03		
444TD	20	18	0.25	22	0.81	8	3.375	8.5	2.88	0.875	6.93		
445TSD	20	18	0.25	22	0.81	8	2.375	4.75	2.021	0.625	3.03		
445TD	20	18	0.25	22	0.81	8	3.375	8.5	2.88	0.875	6.93		
447TSD	20	18	0.25	22	0.81	8	2.375	4.75	2.021	0.625	3.03		
447TD	20	18	0.25	22	0.81	8	3.375	8.5	2.88	0.875	6.93		
449TSD	20	18	0.25	22	0.81	8	2.375	4.75	2.021	0.625	3.03		
449TD	20	18	0.25	22	0.81	8	3.375	8.5	2.88	0.875	6.93		

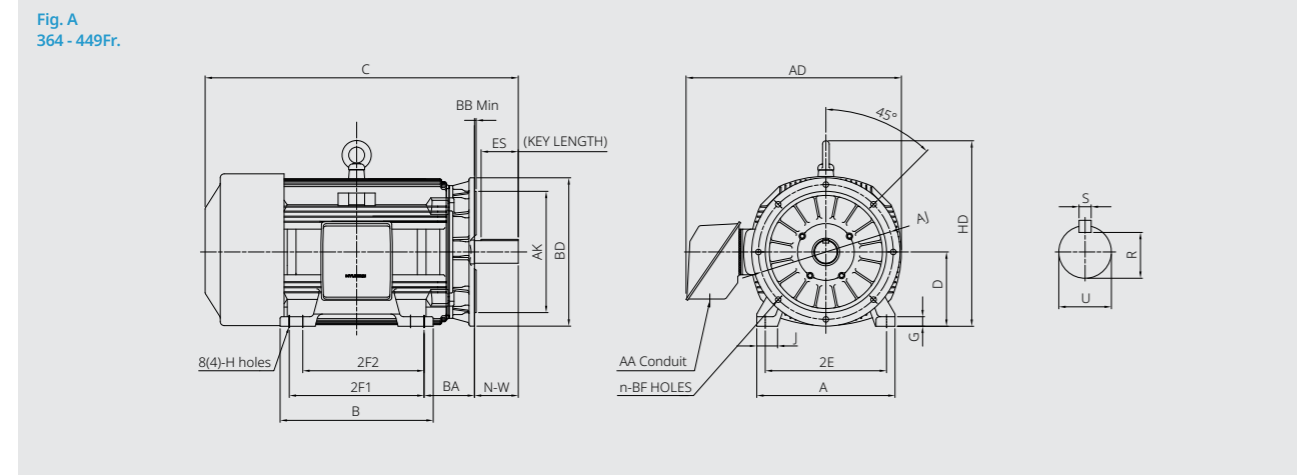

IEEE HL Model - IEEE841, Premium Efficiency Three phase, TEFC, C-Face, Footless



Features

- Cast-iron terminal box
- Fully rotatable at 90 increments
- Main Terminal Box F1 ↔ F2 Field convertible
- Protech seal

C-Face, Footless NEMA Dimensions (Fr. 143 - 326)

Frame Size	C-Face								Overall			Conduit Box AA	Shaft & Keyway					Fig.
	AJ	AK	BB	BC	BD	BF	n	DEPTH	AD (Approx.)	HD (Approx.)	C (Approx.)		U	N-W	R	S	ES(Length)	
143TCRD	5.875	4.50	0.16	0.12	6.57	3/8-16	4	0.56	10.69	8.96	13.05	3/4"	0.875	2.25	0.771	0.188	1.41	A
145TCRD	5.875	4.50	0.16	0.12	6.57	3/8-16	4	0.56	10.69	8.96	13.05	3/4"	0.875	2.25	0.771	0.188	1.41	
182TCRD	7.25	8.50	0.28	0.12	8.85	1/2-13	4	0.75	12.79	11.15	15.75	3/4"	1.125	2.75	0.986	0.250	1.78	
184TCRD	7.25	8.50	0.28	0.12	8.85	1/2-13	4	0.75	12.79	11.15	15.75	3/4"	1.125	2.75	0.986	0.250	1.78	
213TCRD	7.25	8.50	0.25	0.25	8.81	1/2-13	4	0.75	14.56	12.09	18.51	1"	1.375	3.38	1.201	0.312	2.41	
215TCRD	7.25	8.50	0.25	0.25	8.81	1/2-13	4	0.75	14.56	12.09	19.93	1"	1.375	3.38	1.201	0.312	2.41	C
254TCRD	7.25	8.50	0.25	0.25	9.68	1/2-13	4	0.75	18.23	14.77	23.20	1 1/4"	1.625	4.00	1.416	0.375	2.91	
256TCRD	7.25	8.50	0.25	0.25	9.68	1/2-13	4	0.75	18.23	14.77	24.93	1 1/4"	1.625	4.00	1.416	0.375	2.91	
284TSCRD	9.00	10.50	0.25	0.25	10.90	1/2-13	4	0.75	19.54	16.20	24.91	1 1/2"	1.875	4.62	1.591	0.500	3.28	
284TCRD	9.00	10.50	0.25	0.25	10.90	1/2-13	4	0.75	19.54	16.20	26.28	1 1/2"	1.875	4.62	1.591	0.500	3.28	
286TSCRD	9.00	10.50	0.25	0.25	10.90	1/2-13	4	0.75	19.54	16.20	26.41	1 1/2"	1.625	3.25	1.416	0.375	1.91	
286TCRD	9.00	10.50	0.25	0.25	10.90	1/2-13	4	0.75	19.54	16.20	27.78	1 1/2"	1.875	4.62	1.591	0.500	3.28	
324TSCRD	11.00	12.50	0.25	0.25	13.27	5/8-11	4	0.94	23.23	18.25	31.40	2"	1.875	3.75	1.591	0.500	2.03	
324TCRD	11.00	12.50	0.25	0.25	13.27	5/8-11	4	0.94	23.23	18.25	31.40	2"	2.125	5.25	1.845	0.500	3.91	
326TSCRD	11.00	12.50	0.25	0.25	13.27	5/8-11	4	0.94	23.23	18.25	31.40	2"	1.875	3.75	1.591	0.500	2.03	
326TCRD	11.00	12.50	0.25	0.25	13.27	5/8-11	4	0.94	23.23	18.25	31.40	2"	2.125	5.25	1.845	0.500	3.91	

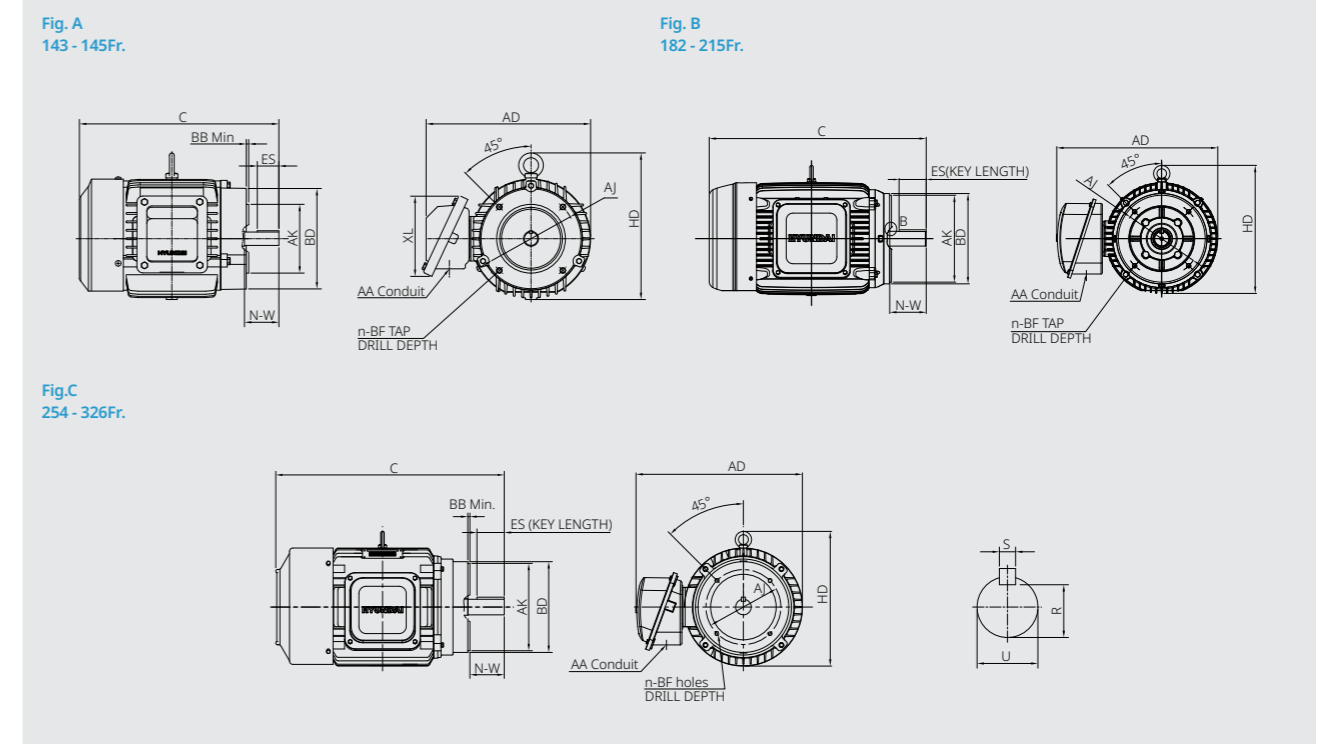

IEEE HL Model - IEEE841, Premium Efficiency Three phase, TEFC, C-Face, Footless



Features

- Cast-iron terminal box
- Fully rotatable at 90 increments
- Main Terminal Box F1 ↔ F2 Field convertible
- Protech seal

C-Face, Footless NEMA Dimensions (Fr. 364 - 449)

Frame Size	C-Face								Overall			Conduit Box		Shaft & Keyway					Fig.
	AJ	AK	BB	BC	BD	BF	n	DEPTH	AD (Approx.)	HD (Approx.)	C (Approx.)	AA	U	N-W	R	S	ES(Length)		
364TSCRD	11.00	12.50	0.25	0.25	13.54	5/8-11	8	0.94	26.01	24.89	33.06	3"	1.875	3.75	1.591	0.500	2.03	A	
364TCRD	11.00	12.50	0.25	0.25	13.54	5/8-11	8	0.94	26.01	24.89	35.20	3"	2.375	5.88	2.021	0.625	4.28		
365TSCRD	11.00	12.50	0.25	0.25	13.54	5/8-11	8	0.94	26.01	24.89	33.06	3"	1.875	3.75	1.591	0.500	2.03		
365TCRD	11.00	12.50	0.25	0.25	13.54	5/8-11	8	0.94	26.01	24.89	35.20	3"	2.375	5.88	2.021	0.625	4.28		
404TCRD	11.00	12.50	0.25	0.25	13.94	5/8-11	8	0.94	30.13	29.30	41.01	3"	2.875	7.25	2.450	0.750	5.65		
405TSCRD	11.00	12.50	0.25	0.25	13.94	5/8-11	8	0.94	30.13	29.30	38.00	3"	2.125	4.25	1.845	0.500	2.80		
405TCRD	11.00	12.50	0.25	0.25	13.94	5/8-11	8	0.94	30.13	29.30	41.01	3"	2.875	7.25	2.450	0.750	5.65		
444TSCRD	14.00	16.00	0.25	0.25	17.48	5/8-11	8	0.94	32.48	32.99	47.15	3"	2.375	4.75	2.021	0.625	3.03		A
444TCRD	14.00	16.00	0.25	0.25	17.48	5/8-11	8	0.94	32.48	32.99	46.45	3"	3.375	8.50	2.880	0.875	6.93		
445TSCRD	14.00	16.00	0.25	0.25	17.48	5/8-11	8	0.94	32.48	32.99	47.15	3"	2.375	4.75	2.021	0.625	3.03		
445TCRD	14.00	16.00	0.25	0.25	17.48	5/8-11	8	0.94	32.48	32.99	46.78	3"	3.375	8.50	2.880	0.875	6.93		
447TSCRD	14.00	16.00	0.25	0.25	17.48	5/8-11	8	0.94	35.00	32.99	50.65	3"	2.375	4.75	2.021	0.625	3.03		
447TCRD	14.00	16.00	0.25	0.25	17.48	5/8-11	8	0.94	35.00	32.99	50.29	3"	3.375	8.50	2.880	0.875	6.93		
449TSCRD	14.00	16.00	0.25	0.25	17.48	5/8-11	8	0.94	35.00	32.99	55.77	3"	2.375	4.75	2.021	0.625	3.03		
449TCRD	14.00	16.00	0.25	0.25	17.48	5/8-11	8	0.94	35.00	32.99	53.83	3"	3.375	8.50	2.880	0.875	6.93		

Fig. A
364 - 449Fr.

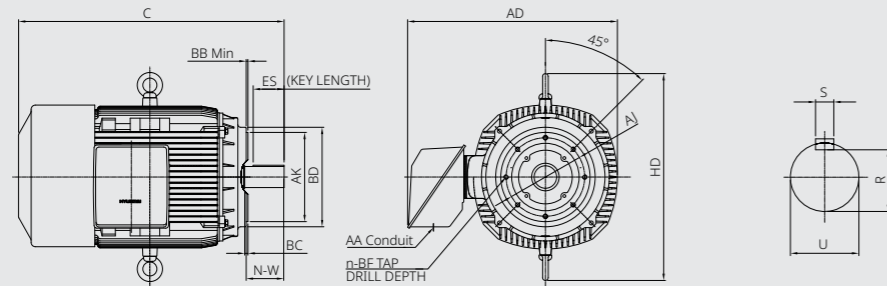

IEEE HL Model - IEEE841, Premium Efficiency Three phase, TEFC, D-Flange, Footless



Features

- Cast-iron terminal box
- Fully rotatable at 90 increments
- Main Terminal Box F1 ↔ F2 Field convertible
- Protech seal

D-Flange, Footless NEMA Dimensions (Fr. 182 - 326)

Frame Size	D-Flange						Overall			Conduit Box		Shaft & Keyway					Fig.
	AJ	AK	BB	BD	BF	n	AD (Approx.)	HD (Approx.)	C (Approx.)	AA	U	N-W	R	S	ES(Length)		
182TDRD	10.00	9.00	0.25	11.00	0.53	4	13.42	11.74	15.75	3/4"	1.125	2.75	0.986	0.25	1.78	A	
184TDRD	10.00	9.00	0.25	11.00	0.53	4	13.42	11.74	15.75	3/4"	1.125	2.75	0.986	0.25	1.78		
213TDRD	10.00	9.00	0.25	11.00	0.53	4	14.70	12.57	18.51	1"	1.375	3.38	1.201	0.312	2.41		
215TDRD	10.00	9.00	0.25	11.00	0.53	4	14.70	12.57	19.99	1"	1.375	3.38	1.201	0.312	2.41		
254TDRD	12.50	11.00	0.25	14.00	0.81	4	18.85	15.39	23.20	1 1/4"	1.625	4.00	1.416	0.375	2.91		
256TDRD	12.50	11.00	0.25	14.00	0.81	4	18.85	15.39	24.93	1 1/4"	1.625	4.00	1.416	0.375	2.91		
284TSDRD	12.50	11.00	0.25	14.00	0.81	4	19.44	16.11	24.91	1 1/2"	1.625	3.25	1.416	0.375	1.91		
284TDRD	12.50	11.00	0.25	14.00	0.81	4	19.44	16.11	26.28	1 1/2"	1.875	4.62	1.591	0.5	3.28		
286TSDRD	12.50	11.00	0.25	14.00	0.81	4	19.44	16.11	26.34	1 1/2"	1.625	3.25	1.416	0.375	1.91		
286TDRD	12.50	11.00	0.25	14.00	0.81	4	19.44	16.11	27.78	1 1/2"	1.875	4.62	1.591	0.5	3.28		
324TSDRD	16.00	14.00	0.25	18.00	0.81	4	25.31	19.33	29.90	2"	1.875	3.75	1.591	0.5	2.03	B	
324TDRD	16.00	14.00	0.25	18.00	0.81	4	25.31	19.33	31.40	2"	2.125	5.25	1.845	0.5	3.91		
326TSDRD	16.00	14.00	0.25	18.00	0.81	4	25.31	19.33	29.90	2"	1.875	3.75	1.591	0.5	2.03		
326TDRD	16.00	14.00	0.25	18.00	0.81	4	25.31	19.33	31.40	2"	2.125	5.25	1.845	0.5	3.91		

Fig. A
182 - 215Fr.

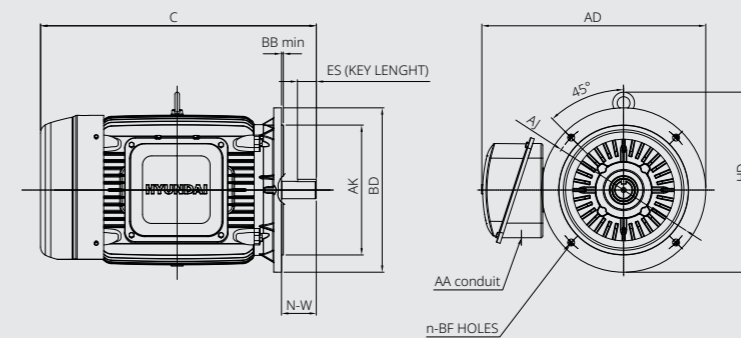
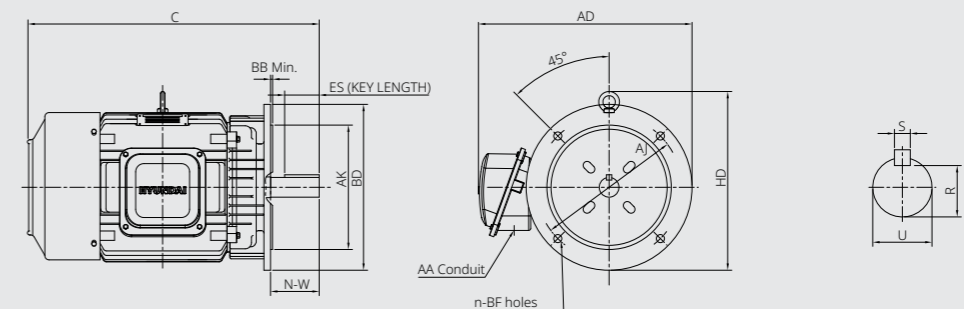

Fig. B
254 - 326Fr.



IEEE HL Model - IEEE841, Premium Efficiency Three phase, TEFC, D-Flange, Footless



Features

- Cast-iron terminal box
- Fully rotatable at 90 increments
- Main Terminal Box F1 ↔ F2 Field convertible
- Protech seal

D-Flange, Footless NEMA Dimensions (Fr. 364 - 449)

Frame Size	D-Flange						Overall			Conduit Box	Shaft & Keyway					Fig.	
	AJ	AK	BB	BD	BF	n	AD (Approx.)	HD (Approx.)	C (Approx.)	AA	U	N-W	R	S	ES(Length)		
364TSDRD	16.00	14.00	0.25	17.99	0.81	8	26.13	24.89	33.06	3"	1.875	3.75	1.591	0.5	2.03	A	
364TDRD	16.00	14.00	0.25	17.99	0.81	8	26.13	24.89	35.20	3"	2.375	5.88	2.021	0.625	4.28		
365TSDRD	16.00	14.00	0.25	17.99	0.81	8	26.13	24.89	33.06	3"	1.875	3.75	1.591	0.5	2.03		
365TDRD	16.00	14.00	0.25	17.99	0.81	8	26.13	24.89	35.20	3"	2.375	5.88	2.021	0.625	4.28		
404TDRD	20.00	18.00	0.25	21.65	0.81	8	31.11	29.30	41.01	3"	2.875	7.25	2.450	0.75	5.65		
405TSDRD	20.00	18.00	0.25	21.65	0.81	8	31.11	29.30	38.00	3"	2.125	4.25	1.845	0.5	2.8		
405TDRD	20.00	18.00	0.25	21.65	0.81	8	31.11	29.30	41.01	3"	2.875	7.25	2.450	0.75	5.65		
444TSDRD	20.00	18.00	0.25	22.00	0.81	8	32.26	32.99	47.15	3"	2.375	4.75	2.021	0.625	3.03		A
444TDRD	20.00	18.00	0.25	22.00	0.81	8	32.26	32.99	46.45	3"	3.375	8.50	2.880	0.875	6.93		
445TSDRD	20.00	18.00	0.25	22.00	0.81	8	32.26	32.99	47.15	3"	2.375	4.75	2.021	0.625	3.03		
445TDRD	20.00	18.00	0.25	22.00	0.81	8	32.26	32.99	46.78	3"	3.375	8.50	2.880	0.875	6.93		
447TSDRD	20.00	18.00	0.25	22.00	0.81	8	34.78	32.99	50.65	3"	2.375	4.75	2.021	0.625	3.03		
447TDRD	20.00	18.00	0.25	22.00	0.81	8	34.78	32.99	50.29	3"	3.375	8.50	2.880	0.875	6.93		
449TSDRD	20.00	18.00	0.25	22.00	0.81	8	34.78	32.99	55.77	3"	2.375	4.75	2.021	0.625	3.03		
449TDRD	20.00	18.00	0.25	22.00	0.81	8	34.78	32.99	53.83	3"	3.375	8.50	2.880	0.875	6.93		

Fig. A
364 - 449Fr.

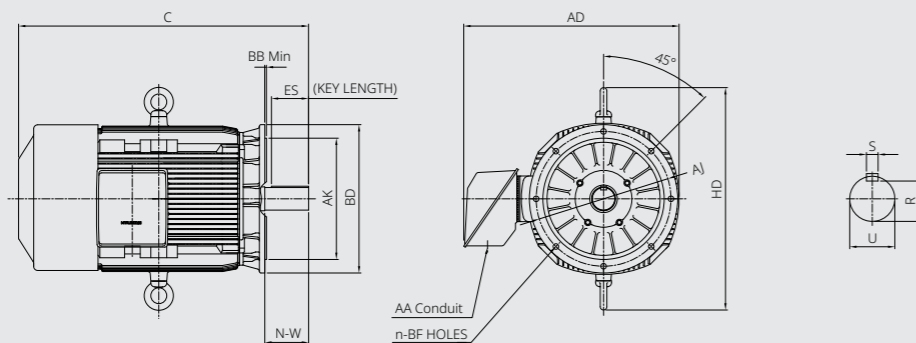

IEEE HL Model - IEEE841, Premium Efficiency Three phase, TEFC, Vertical, C-Face, Footless



Features

- Cast-iron terminal box
- Fully rotatable at 90 increments
- Main Terminal Box F1 ↔ F2 Field convertible
- Protech seal

Vertical, C-Face, Footless NEMA Dimensions (Fr. 143 - 326)

Frame Size	C-Face								Overall			Conduit Box	Shaft & Keyway					Fig.
	AJ	AK	BB	BC	BD	BF	n	DEPTH	AD (Approx.)	HD (Approx.)	C (Approx.)	AA	U	N-W	R	S	ES(Length)	
143TCRDV	5.875	4.50	0.16	0.12	6.57	3/8-16	4	0.56	10.69	8.96	13.05	3/4"	0.875	2.25	0.771	0.188	1.41	A
145TCRDV	5.875	4.50	0.16	0.12	6.57	3/8-16	4	0.56	10.69	8.96	13.05	3/4"	0.875	2.25	0.771	0.188	1.41	
182TCRDV	7.25	8.50	0.28	0.12	8.85	1/2-13	4	0.75	12.79	12.46	16.93	3/4"	1.125	2.75	0.986	0.250	1.78	
184TCRDV	7.25	8.50	0.28	0.12	8.85	1/2-13	4	0.75	12.79	12.46	16.93	3/4"	1.125	2.75	0.986	0.250	1.78	B
213TCRDV	7.25	8.50	0.25	0.25	8.81	1/2-13	4	0.75	14.56	14.13	19.69	1"	1.375	3.38	1.201	0.312	2.41	
215TCRDV	7.25	8.50	0.25	0.25	8.81	1/2-13	4	0.75	14.56	14.13	21.17	1"	1.375	3.38	1.201	0.312	2.41	
254TCRDV	7.25	8.50	0.25	0.25	9.68	1/2-13	4	0.75	18.23	14.77	25.01	1 1/4"	1.625	4.00	1.416	0.375	2.91	C
256TCRDV	7.25	8.50	0.25	0.25	9.68	1/2-13	4	0.75	18.23	14.77	26.73	1 1/4"	1.625	4.00	1.416	0.375	2.91	
284TSCRDV	9.00	10.50	0.25	0.25	10.90	1/2-13	4	0.75	18.95	16.20	26.72	1 1/2"	1.625	3.25	1.416	0.375	1.91	
284TCRDV	9.00	10.50	0.25	0.25	10.90	1/2-13	4	0.75	19.54	16.20	28.09	1 1/2"	1.875	4.62	1.591	0.500	3.28	
286TSCRDV	9.00	10.50	0.25	0.25	10.90	1/2-13	4	0.75	19.54	16.20	25.22	1 1/2"	1.625	3.25	1.416	0.375	1.91	
286TCRDV	9.00	10.50	0.25	0.25	10.90	1/2-13	4	0.75	19.54	16.20	29.59	1 1/2"	1.875	4.62	1.591	0.500	3.28	
324TSCRDV	11.00	12.50	0.25	0.25	13.27	5/8-11	4	0.94	24.23	18.25	31.71	2"	1.875	3.75	1.591	0.500	2.03	
324TCRDV	11.00	12.50	0.25	0.25	13.27	5/8-11	4	0.94	24.23	18.25	33.21	2"	2.125	5.25	1.845	0.500	3.91	
326TSCRDV	11.00	12.50	0.25	0.25	13.27	5/8-11	4	0.94	24.23	18.25	31.71	2"	1.875	3.75	1.591	0.500	2.03	
326TCRDV	11.00	12.50	0.25	0.25	13.27	5/8-11	4	0.94	24.23	18.25	33.21	2"	2.125	5.25	1.845	0.500	3.91	

Fig. A
143 - 145Fr.

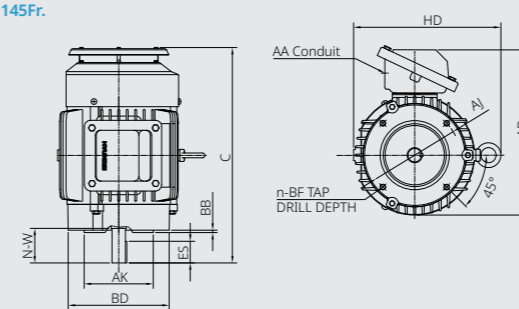

Fig. B
182 - 215Fr.

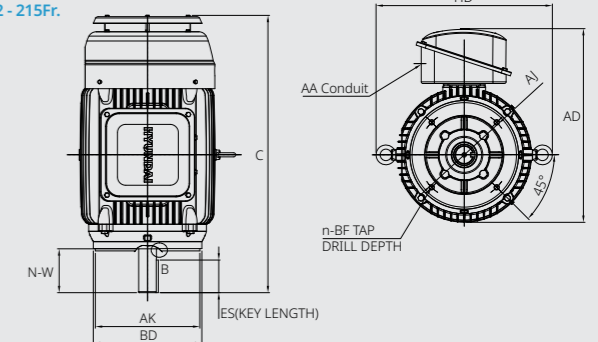
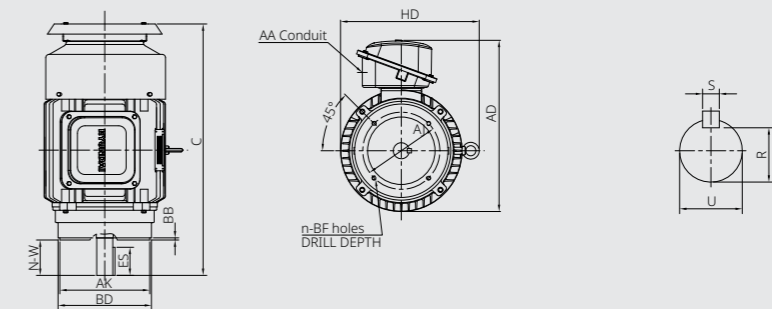

Fig. C
254 - 326Fr.



IEEE HL Model - IEEE841, Premium Efficiency Three phase, TEFC, Vertical, C-Face, Footless



Features

- Cast-iron terminal box
- Fully rotatable at 90 increments
- Main Terminal Box F1 ↔ F2 Field convertible
- Protech seal

Vertical, C-Face, Footless NEMA Dimensions (Fr. 364 - 449)

Frame Size	C-Face								Overall			Conduit Box		Shaft & Keyway					Fig.
	AJ	AK	BB	BC	BD	BF	n	DEPTH	AD (Approx.)	HD (Approx.)	C (Approx.)	AA	U	N-W	R	S	ES(Length)		
364TSCRDV	11.00	12.50	0.25	0.25	13.54	5/8-11	8	0.94	26.01	24.89	34.65	3"	1.875	3.75	1.591	0.500	2.03	A	
364TCRDV	11.00	12.50	0.25	0.25	13.54	5/8-11	8	0.94	26.01	24.89	32.15	3"	2.375	5.88	2.021	0.625	4.28		
365TSCRDV	11.00	12.50	0.25	0.25	13.54	5/8-11	8	0.94	26.01	24.89	35.65	3"	1.875	3.75	1.591	0.500	2.03		
365TCRDV	11.00	12.50	0.25	0.25	13.54	5/8-11	8	0.94	26.01	24.89	32.15	3"	2.375	5.88	2.021	0.625	4.28		
404TCRDV	11.00	12.50	0.25	0.25	13.94	5/8-11	8	0.94	30.13	29.30	42.45	3"	2.875	7.25	2.450	0.750	5.65		
405TSCRDV	11.00	12.50	0.25	0.25	13.94	5/8-11	8	0.94	30.13	29.30	39.45	3"	2.125	4.25	1.845	0.500	2.80		
405TCRDV	11.00	12.50	0.25	0.25	13.94	5/8-11	8	0.94	30.13	29.30	42.45	3"	2.875	7.25	2.450	0.750	5.65		
444TSCRDV	14.00	16.00	0.25	0.25	17.48	5/8-11	8	0.94	32.48	32.99	48.78	3"	2.375	4.75	2.021	0.625	3.03		A
444TCRDV	14.00	16.00	0.25	0.25	17.48	5/8-11	8	0.94	32.48	32.99	44.06	3"	3.375	8.50	2.880	0.875	6.93		
445TSCRDV	14.00	16.00	0.25	0.25	17.48	5/8-11	8	0.94	32.48	32.99	48.78	3"	2.375	4.75	2.021	0.625	3.03		
445TCRDV	14.00	16.00	0.25	0.25	17.48	5/8-11	8	0.94	32.48	32.99	47.81	3"	3.375	8.50	2.880	0.875	6.93		
447TSCRDV	14.00	16.00	0.25	0.25	17.48	5/8-11	8	0.94	35.00	32.99	52.29	3"	2.375	4.75	2.021	0.625	3.03		
447TCRDV	14.00	16.00	0.25	0.25	17.48	5/8-11	8	0.94	35.00	32.99	52.57	3"	3.375	8.50	2.880	0.875	6.93		
449TSCRDV	14.00	16.00	0.25	0.25	17.48	5/8-11	8	0.94	35.00	32.99	57.29	3"	2.375	4.75	2.021	0.625	3.03		
449TCRDV	14.00	16.00	0.25	0.25	17.48	5/8-11	8	0.94	35.00	32.99	56.69	3"	3.375	8.50	2.880	0.875	6.93		

Fig. A
364 - 449Fr.

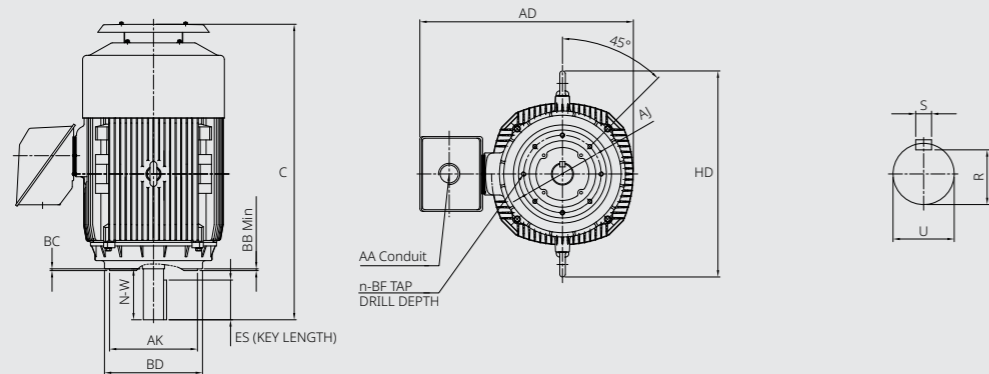

IEEE HL Model - IEEE841, Premium Efficiency Three phase, TEFC, Vertical, D-Flange, Footless



Features

- Cast-iron terminal box
- Fully rotatable at 90 increments
- Main Terminal Box F1 ↔ F2 Field convertible
- Protech seal

Vertical, D-Flange, Footless NEMA Dimensions (Fr. 182 - 326)

Frame Size	D-Flange						Overall			Conduit Box		Shaft & Keyway					Fig.
	AJ	AK	BB	BD	BF	n	AD (Approx.)	HD (Approx.)	C (Approx.)	AA	U	N-W	R	S	ES(Length)		
182TDRDV	10.00	9.00	0.25	11.00	0.53	4	13.42	12.46	16.93	3/4"	1.125	2.75	0.986	0.25	1.78	A	
184TDRDV	10.00	9.00	0.25	11.00	0.53	4	13.42	12.46	16.93	3/4"	1.125	2.75	0.986	0.25	1.78		
213TDRDV	10.00	9.00	0.25	11.00	0.53	4	15.13	14.13	19.69	1"	1.375	3.38	1.201	0.312	2.41		
215TDRDV	10.00	9.00	0.25	11.00	0.53	4	15.13	14.13	21.17	1"	1.375	3.38	1.201	0.312	2.41		
254TDRDV	12.50	11.00	0.25	14.00	0.81	4	18.85	15.39	25.01	1 1/4"	1.625	4.00	1.416	0.375	2.91		
256TDRDV	12.50	11.00	0.25	14.00	0.81	4	18.85	15.39	26.74	1 1/4"	1.625	4.00	1.416	0.375	2.91		
284TSDRDV	12.50	11.00	0.25	14.00	0.81	4	19.44	16.11	26.72	1 1/2"	1.625	3.25	1.416	0.375	1.91		
284TDRDV	12.50	11.00	0.25	14.00	0.81	4	19.44	16.11	28.09	1 1/2"	1.875	4.62	1.591	0.5	3.28		
286TSDRDV	12.50	11.00	0.25	14.00	0.81	4	19.44	16.11	28.22	1 1/2"	1.625	3.25	1.416	0.375	1.91		
286TDRDV	12.50	11.00	0.25	14.00	0.81	4	19.44	16.11	29.59	1 1/2"	1.875	4.62	1.591	0.5	3.28		
324TSDRDV	16.00	14.00	0.25	18.00	0.81	4	25.31	19.33	31.71	2"	1.875	3.75	1.591	0.5	2.03	B	
324TDRDV	16.00	14.00	0.25	18.00	0.81	4	25.31	19.33	33.21	2"	2.125	5.25	1.845	0.5	3.91		
326TSDRDV	16.00	14.00	0.25	18.00	0.81	4	25.31	19.33	31.71	2"	1.875	3.75	1.591	0.5	2.03		
326TDRDV	16.00	14.00	0.25	18.00	0.81	4	25.31	19.33	33.21	2"	2.125	5.25	1.845	0.5	3.91		

Fig. A
182 - 215Fr.

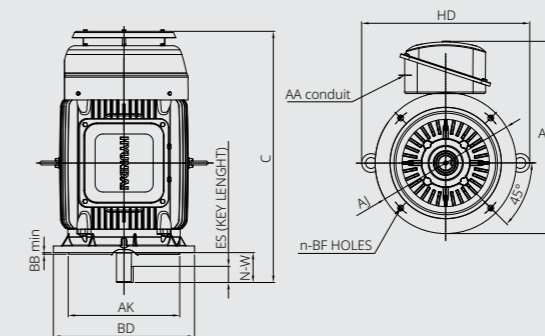
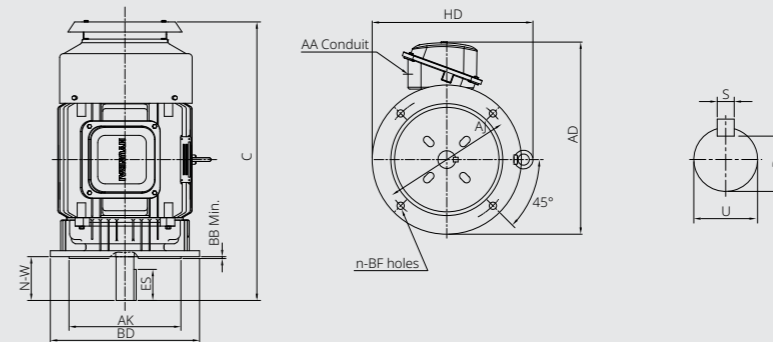

Fig. B
254 - 326Fr.



IEEE HL Model - IEEE841, Premium Efficiency Three phase, TEFC, Vertical, D-Flange, Footless



Features

- Cast-iron terminal box
- Fully rotatable at 90 increments
- Main Terminal Box F1 ↔ F2 Field convertible
- Protech seal

Vertical, D-Flange, Footless NEMA Dimensions (Fr. 364 - 449)

Frame Size	D-Flange						Overall			Conduit Box		Shaft & Keyway					Fig.
	AJ	AK	BB	BD	BF	n	AD (Approx.)	HD (Approx.)	C (Approx.)	AA	U	N-W	R	S	ES(Length)		
364TSDRDV	16.00	14.00	0.25	17.99	0.81	8	26.01	24.89	34.50	3"	1.875	3.75	1.591	0.5	2.03		
364TDRDV	16.00	14.00	0.25	17.99	0.81	8	26.01	24.89	36.62	3"	2.375	5.88	2.021	0.625	4.28		
365TSDRDV	16.00	14.00	0.25	17.99	0.81	8	26.01	24.89	34.50	3"	1.875	3.75	1.591	0.5	2.03		
365TDRDV	16.00	14.00	0.25	17.99	0.81	8	26.01	24.89	36.62	3"	2.375	5.88	2.021	0.625	4.28		
404TDRDV	20.00	18.00	0.25	21.65	0.81	8	30.13	29.30	42.02	3"	2.875	7.25	2.450	0.75	5.65		
405TSDRDV	20.00	18.00	0.25	21.65	0.81	8	30.13	29.30	39.02	3"	2.125	4.25	1.845	0.5	2.8		
405TDRDV	20.00	18.00	0.25	21.65	0.81	8	30.13	29.30	42.02	3"	2.875	7.25	2.450	0.75	5.65		
444TSDRDV	20.00	18.00	0.25	22.00	0.81	8	32.48	32.99	48.78	3"	2.375	4.75	2.021	0.625	3.03		
444TDRDV	20.00	18.00	0.25	22.00	0.81	8	32.48	32.99	47.72	3"	3.375	8.50	2.880	0.875	6.93		
445TSDRDV	20.00	18.00	0.25	22.00	0.81	8	32.48	32.99	48.78	3"	2.375	4.75	2.021	0.625	3.03		
445TDRDV	20.00	18.00	0.25	22.00	0.81	8	32.48	32.99	47.72	3"	3.375	8.50	2.880	0.875	6.93		
447TSDRDV	20.00	18.00	0.25	22.00	0.81	8	32.48	32.99	52.26	3"	2.375	4.75	2.021	0.625	3.03		
447TDRDV	20.00	18.00	0.25	22.00	0.81	8	32.48	32.99	51.23	3"	3.375	8.50	2.880	0.875	6.93		
449TSDRDV	20.00	18.00	0.25	22.00	0.81	8	32.48	32.99	56.87	3"	2.375	4.75	2.021	0.625	3.03		
449TDRDV	20.00	18.00	0.25	22.00	0.81	8	32.48	32.99	56.35	3"	3.375	8.50	2.880	0.875	6.93		

Fig. A
364 - 449Fr.

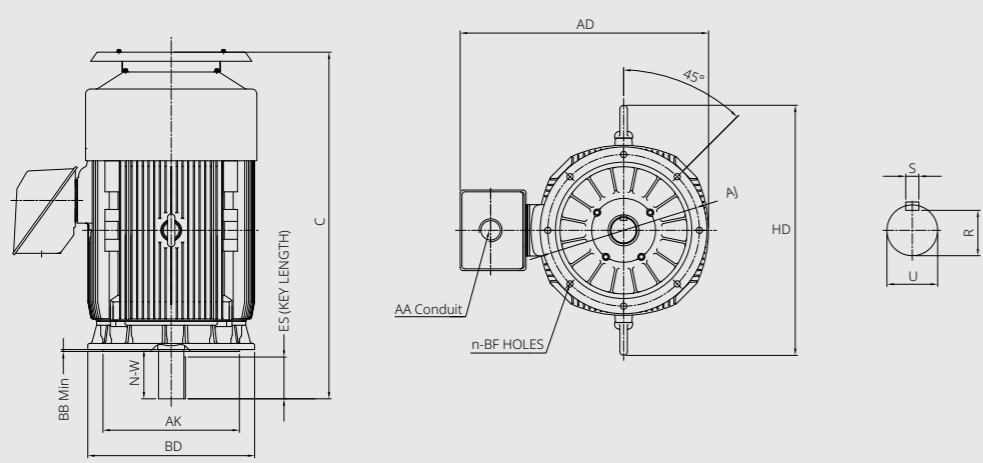

IXHHI Model - Explosion proof, Premium Efficiency Three phase, TEFC, Foot mounted



Features

- Cast-iron terminal box
- Fully rotatable at 90 increments
- Main Terminal Box F1 ↔ F2 Field convertible
- Class I Division 1 (Fr. 143 - 449) / Class II Division 1 (Fr. 143 - 326)

Foot Mounted NEMA Dimensions

Frame Size	Mounting & Overall											AD (Approx.)	HD (Approx.)	C (Approx.)	Shaft & Keyway					Conduit Box AA	Fig.
	D	2E	J	A	G	2F1	2F2	B	BA	n	H				U	N-W	R	S	ES		
143T	3.5	5.5	1.36	6.78	0.47	-	4	6.15	2.25	8	0.34	12.21	9.09	13.05	0.875	2.25	0.771	0.188	1.41	3/4"	
145T	3.5	5.5	1.36	6.78	0.47	5	-	6.15	2.25	8	0.34	12.21	9.09	13.05	0.875	2.25	0.771	0.188	1.41	3/4"	
182T	4.5	7.5	1.74	8.66	0.62	4.5	-	5.52	2.75	4	0.41	14.2	10.95	15.52	1.125	2.75	0.986	0.25	1.78	3/4"	
184T	4.5	7.5	1.74	8.66	0.62	5.5	-	6.54	2.75	8	0.41	14.2	10.95	16.55	1.125	2.75	0.986	0.25	1.78	3/4"	
213T	5.25	8.5	1.52	9.85	0.6	5.5	-	6.77	3.5	4	0.41	15.78	12.65	18.86	1.375	3.38	1.201	0.312	2.41	1"	
215T	5.25	8.5	1.52	9.84	0.6	7	-	8.66	3.5	8	0.41	15.78	12.65	20.36	1.375	3.38	1.201	0.312	2.41	1"	
254T	6.25	10	1.93	11.30	0.72	8.25	-	9.56	4.25	4	0.53	18.39	14.76	23.13	1.625	4.00	1.416	0.375	2.91	1 1/4"	
256T	6.25	10	1.93	11.30	0.72	10	-	11.3	4.25	4	0.53	18.39	14.76	24.86	1.625	4.00	1.416	0.375	2.91	1 1/4"	
284TS	7	11	2.20	12.60	0.78	9.5	-	11.18	4.75	4	0.53	19.70	16.29	24.84	1.625	3.25	1.416	0.375	1.91	1 1/2"	
284T	7	11	2.20	12.60	0.78	9.5	-	11.18	4.75	4	0.53	19.70	16.29	26.21	1.875	4.62	1.591	0.5	3.28	1 1/2"	
286TS	7	11	2.20	12.60	0.78	11	-	12.68	4.75	4	0.53	19.70	16.29	26.34	1.625	3.25	1.416	0.375	1.91	1 1/2"	
286T	7	11	2.20	12.60	0.78	11	-	12.68	4.75	4	0.53	19.70	16.29	27.71	1.875	4.62	1.591	0.5	3.28	1 1/2"	
324TS	8	12.5	2.36	14.33	1.11	-	10.5	15.74	5.25	12	0.66	23.19	18.6	31.53	1.875	3.75	1.591	0.5	2.03	2"	
324T	8	12.5	2.36	14.33	1.11	-	10.5	15.74	5.25	12	0.66	23.19	18.6	33.03	2.125	5.25	1.845	0.5	3.91	2"	
326TS	8	12.5	2.36	14.33	1.11	12	-	15.74	5.25	12	0.66	23.19	18.6	31.53	1.875	3.75	1.591	0.5	2.03	2"	
326T	8	12.5	2.36	14.33	1.11	12	-	15.74	5.25	12	0.66	23.19	18.6	33.03	2.125	5.25	1.845	0.5	3.91	2"	
364TS	9	14	2.44	15.98	0.98	-	11.25	14.41	5.88	8	0.66	27.91	21.5	34.01	1.875	3.75	1.591	0.5	2.03	3"	
364T	9	14	2.44	15.98	0.98	-	11.25	14.41	5.88	8	0.66	27.91	21.5	34.38	2.375	5.88	2.021	0.625	4.28	3"	
365TS	9	14	2.44	15.98	0.98	12.25	-	14.41	5.88	8	0.66	27.91	21.5	34.01	1.875	3.75	1.591	0.5	2.03	3"	
365T	9	14	2.44	15.98	0.98	12.25	-	14.41	5.88	8	0.66	27.91	21.5	34.38	2.375	5.88	2.021	0.625	4.28	3"	
404T	10	16	2.59	18.11	1.18	-	12.25	15.98	6.62	8	0.81	32.83	24.49	39.33	2.449	7.25	2.45	0.75	5.65	3"	
405TS	10	16	2.59	18.11	1.18	13.75	-	15.98	6.62	8	0.81	32.83	24.49	36.33	2.125	4.25	1.845	0.5	2.8	3"	
405T	10	16	2.59	18.11	1.18	13.75	-	15.98	6.62	8	0.81	32.83	24.49	39.33	2.875	7.25	2.45	0.75	5.65	3"	
444TS	11	18	2.56	20.00	1.53	-	14.5	18.81	7.5	8	0.81	35.00	27.71	41.4	2.375	4.75	2.021	0.625	3.03	3"	
444T	11	18	2.56	20.00	1.53	-	14.5	18.81	7.5	8	0.81	35.00	27.71	45.15	3.375	8.5	2.88	0.875	6.93	3"	
445TS	11	18	2.56	20.00	1.53	16.5	-	18.81	7.5	8	0.81	35.00	27.71	41.4	2.375	4.75	2.021	0.625	3.03	3"	
445T	11	18	2.56	20.00	1.53	16.5	-	18.81	7.5	8	0.81	35.00	27.71	45.15	3.375	8.5	2.88	0.875	6.93	3"	
447TS	11	18	2.56	20.00	1.53	-	20	27.28	7.5	8	0.81	35.00	27.71	50.57	2.375	4.75	2.021	0.625	3.03	3"	
447T	11	18	2.56	20.00	1.53	-	20	27.28	7.5	8	0.81	35.00	27.71	54.32	3.375	8.5	2.88	0.875	6.93	3"	
449TS	11	18	2.56	20.00	1.53	25	-	27.28	7.5	8	0.81	35.00	27.71	50.57	2.375	4.75	2.021	0.625	3.03	3"	
449T	11	18	2.56	20.00	1.53	25	-	27.28	7.5	8	0.81	35.00	27.71	54.32	3.375	8.5	2.88	0.875	6.93	3"	

Fig. A
143 - 326Fr.

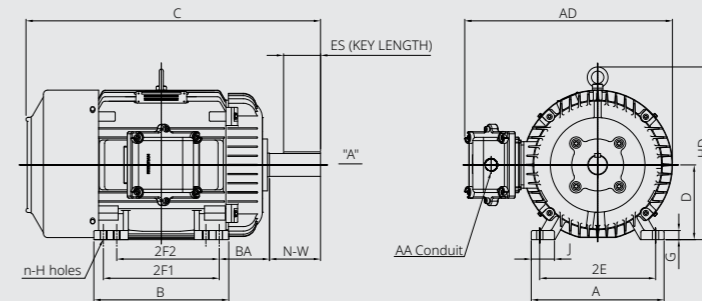
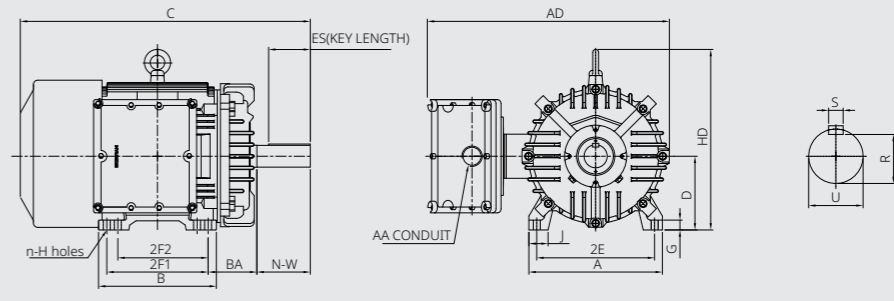

Fig. B
364 - 449Fr.



IXHHI Model - Explosion proof, Premium Efficiency Three phase, TEFC, C-Face, Foot mounted



Features

- Cast-iron terminal box
- Fully rotatable at 90 increments
- Main Terminal Box F1 ↔ F2 Field convertible
- Class I Division 1 (Fr. 143 - 326) / Class II Division 1 (Fr. 143 - 326)

C-Face, Foot Mounted NEMA Dimensions

Frame Size	Mounting & Overall											AD (Approx.)	HD (Approx.)	C (Approx.)	Shaft & Keyway					Conduit Box AA	Fig.
	D	2E	J	A	G	2F1	2F2	B	BA	k	H				U	N-W	R	S	ES		
143TC	3.5	5.5	1.36	6.78	0.45	-	4	6.15	2.25	8	0.34	12.36	9.09	13.05	0.875	2.25	0.771	0.188	1.41	3/4"	A
145TC	3.5	5.5	1.36	6.78	0.45	5	-	6.15	2.25	8	0.34	12.36	9.09	13.05	0.875	2.25	0.771	0.188	1.41	3/4"	
182TC	4.5	7.5	1.74	8.66	0.62	4.5	-	5.52	2.75	4	0.41	14.35	10.95	15.52	1.125	2.75	0.986	0.250	1.78	3/4"	
184TC	4.5	7.5	1.74	8.66	0.62	5.5	-	6.54	2.75	8	0.41	14.35	10.95	16.55	1.125	2.75	0.986	0.250	1.78	3/4"	
213TC	5.25	8.5	1.52	9.85	0.60	5.5	-	6.77	3.50	4	0.41	15.93	12.65	18.86	1.375	3.38	1.201	0.312	2.41	1"	
215TC	5.25	8.5	1.52	9.84	0.60	7	-	8.66	3.50	8	0.41	15.93	12.65	20.36	1.375	3.38	1.201	0.312	2.41	1"	
254TC	6.25	10	1.93	11.30	0.72	8.25	-	9.56	4.25	4	0.53	18.39	14.76	23.13	1.625	4.00	1.416	0.375	2.91	1 1/4"	
256TC	6.25	10	1.93	11.30	0.72	10	-	11.3	4.25	4	0.53	18.39	14.76	24.86	1.625	4.00	1.416	0.375	2.91	1 1/4"	
284TSC	7	11	2.20	12.60	0.78	9.5	-	11.18	4.75	4	0.53	19.70	16.29	24.65	1.625	3.25	1.416	0.375	1.91	1 1/2"	
284TC	7	11	2.20	12.60	0.78	9.5	-	11.18	4.75	4	0.53	19.70	16.29	26.02	1.875	4.62	1.591	0.500	3.28	1 1/2"	
286TSC	7	11	2.20	12.60	0.78	11	-	12.68	4.75	4	0.53	19.70	16.29	26.15	1.625	3.25	1.416	0.375	1.91	1 1/2"	
286TC	7	11	2.20	12.60	0.78	11	-	12.68	4.75	4	0.53	19.70	16.29	27.52	1.875	4.62	1.591	0.500	3.28	1 1/2"	
324TSC	8	12.5	2.44	14.33	1.11	-	10.5	13.78	5.25	12	0.66	23.19	18.6	31.53	1.875	3.75	1.591	0.500	2.03	2"	
324TC	8	12.5	2.36	14.33	1.11	-	10.5	13.78	5.25	12	0.66	23.19	18.6	33.03	2.125	5.25	1.845	0.500	3.91	2"	
326TSC	8	12.5	2.44	14.33	1.11	12	-	13.78	5.25	12	0.66	23.19	18.6	31.53	1.875	3.75	1.591	0.500	2.03	2"	
326TC	8	12.5	2.36	14.33	1.11	12	-	13.78	5.25	12	0.66	23.19	18.6	33.03	2.125	5.25	1.845	0.500	3.91	2"	

Frame Size	C-FACE								Shaft & Keyway					Fig.
	AJ	AK	BB	BC	BD	BF	n	DEPTH	U	N-W	R	S	ES(Length)	
143TC	5.875	4.50	0.16	0.12	6.50	3/8-16	4	0.56	0.875	2.25	0.771	0.188	1.41	
145TC	5.875	4.50	0.16	0.12	6.50	3/8-16	4	0.56	0.875	2.25	0.771	0.188	1.41	
182TC	7.25	8.50	0.25	0.12	8.70	1/2-13	4	0.75	1.125	2.75	0.986	0.250	1.78	
184TC	7.25	8.50	0.25	0.12	8.70	1/2-13	4	0.75	1.125	2.75	0.986	0.250	1.78	
213TC	7.25	8.50	0.25	0.25	9.00	1/2-13	4	0.75	1.375	3.38	1.201	0.312	2.41	
215TC	7.25	8.50	0.25	0.25	9.00	1/2-13	4	0.75	1.375	3.38	1.201	0.312	2.41	
254TC	7.25	8.50	0.25	0.25	9.68	1/2-13	4	0.75	1.625	4.00	1.416	0.375	2.91	
256TC	7.25	8.50	0.25	0.25	9.68	1/2-13	4	0.75	1.625	4.00	1.416	0.375	2.91	
284TSC	9.0	10.50	0.25	0.25	10.90	1/2-13	4	0.75	1.625	3.25	1.416	0.375	1.91	
284TC	9.0	10.50	0.25	0.25	10.90	1/2-13	4	0.75	1.875	4.62	1.591	0.500	3.28	
286TSC	9.0	10.50	0.25	0.25	10.90	1/2-13	4	0.75	1.625	3.25	1.416	0.375	1.91	
286TC	9.0	10.50	0.25	0.25	10.90	1/2-13	4	0.75	1.875	4.62	1.591	0.500	3.28	
324TSC	11.0	12.50	0.25	0.25	13.27	5/8-11	4	0.94	1.875	3.75	1.591	0.500	2.03	
324TC	11.0	12.50	0.25	0.25	13.27	5/8-11	4	0.94	2.125	5.25	1.845	0.500	3.91	
326TSC	11.0	12.50	0.25	0.25	13.27	5/8-11	4	0.94	1.875	3.75	1.591	0.500	2.03	
326TC	11.0	12.50	0.25	0.25	13.27	5/8-11	4	0.94	2.125	5.25	1.845	0.500	3.91	

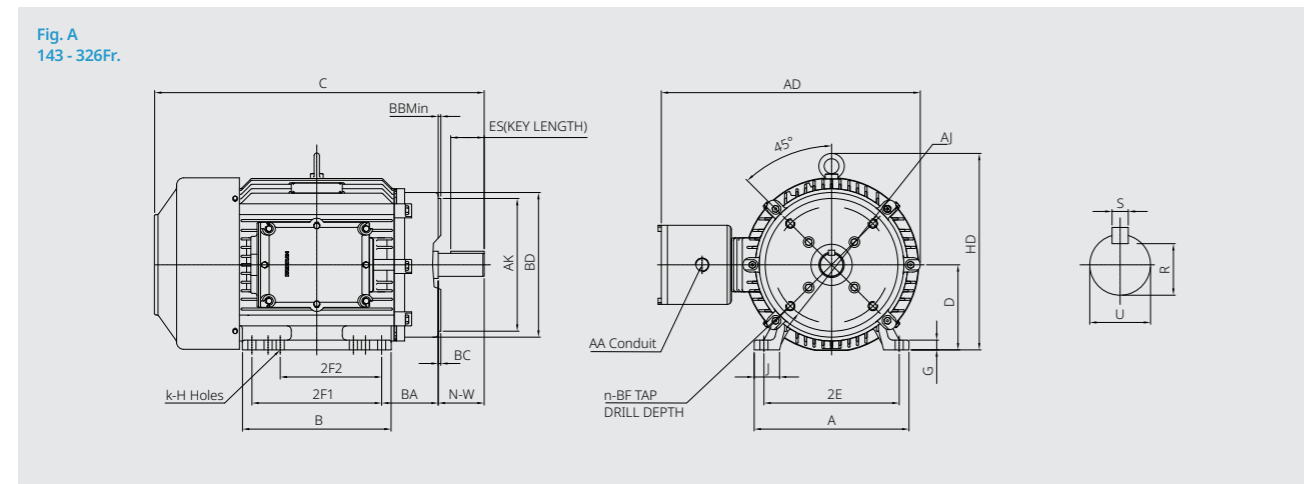

Products in Stock (Location)

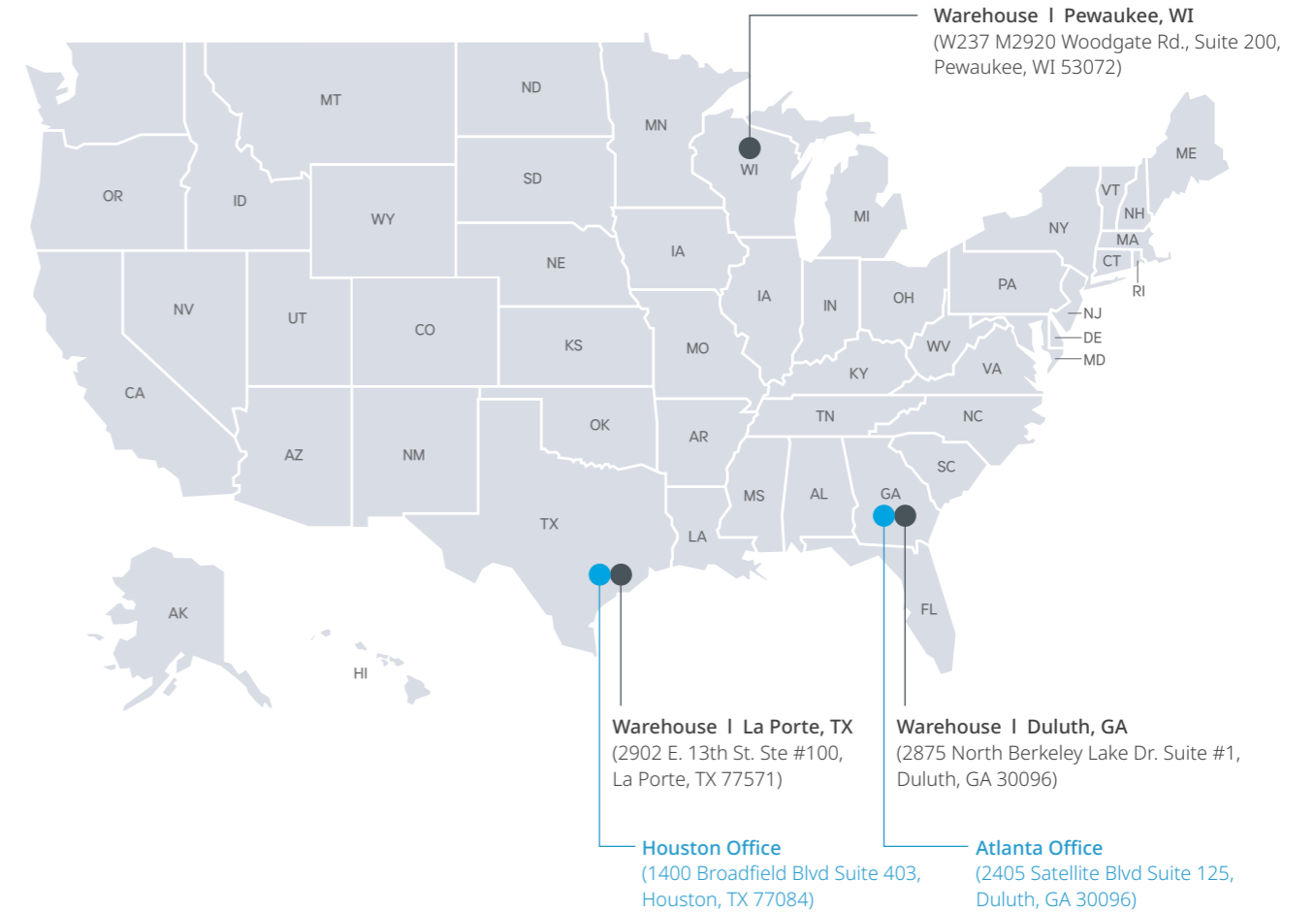

In-Stock and Ready to Ship

Our goal and value lie in holding the products our customers need in stock and swiftly responding to their demands, making them more competitive.



Warehouse in stock | La Porte, TX



Warehouse in stock | Duluth, GA

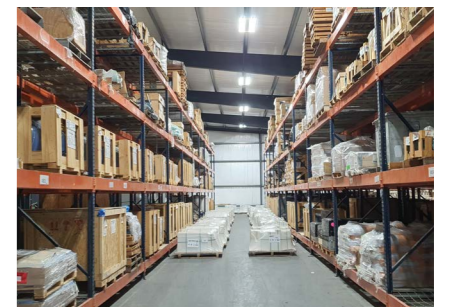

Warehouse in stock | Pewaukee, WI

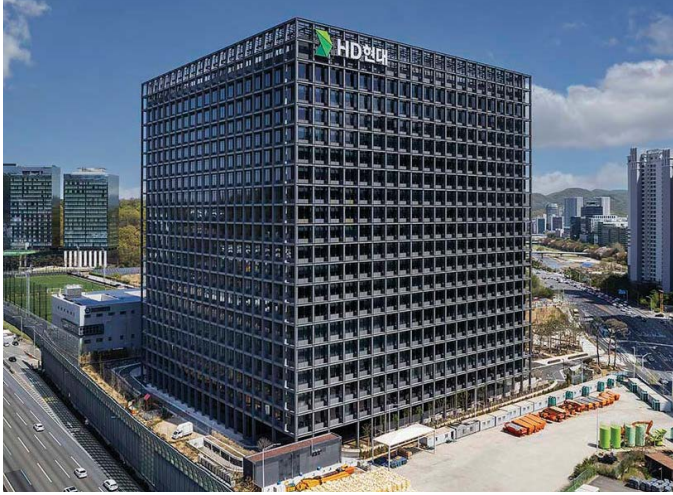

HD HYUNDAI HEADQUARTERS (South Korea)



HD HYUNDAI ELECTRIC AMERICA (Houston, U.S.)



HD HYUNDAI ELECTRIC AMERICA WAREHOUSE (Houston, U.S.)

HD Hyundai Electric America (U.S)

(Office)

Houston	1400 Broadfield Blvd Suite 403, Houston, TX 77084	(+1) 770-654-7108	Lvmotor@heamerica.com
Atlanta	2405 Satellite Blvd Suite 125, Duluth, GA 30096	(+1) 678-789-1885	Lvmotor@heamerica.com

(Warehouse)

La Porte	2902 E. 13th St. Ste #100, La Porte, TX 77571	(+1) 770-654-7108	Lvmotor@heamerica.com
Duluth	2875 North Berkeley Lake Dr. Suite #1, Duluth, GA 30096	(+1) 770-654-7108	Lvmotor@heamerica.com
Pewaukee	W237 M2920 Woodgate Rd., Suite 200, Pewaukee, WI 53072	(+1) 770-654-7108	Lvmotor@heamerica.com

HD Hyundai Electric (South Korea)

Headquarters	477 Bundangsuseo-ro, Bundang-gu, Seongnam-si, Gyeonggi-do, Republic of Korea		
Main Factory	700, Bangeojinsunhwando-ro, Dong-gu, Ulsan-si, Republic of Korea		
Vietnamese Factory	Road no. 10, Nhon Trach 6 IZ, Long Tho Ward, Nhon Trach District, Dong Nai Province, Vietnam		