

Instructions for

Three-phase Induction LV Motor



Installation and maintenance for Polyphase AC Induction Motors

*All operations serving transport, installation, connection, operation and maintenance by skilled, qualified and responsible personnel ensures safe and proper use of motors.
Read instructions carefully before attempting to install, operate or service motors and retain for future reference and work with care.
Especially, safety precautions must be observed to protect personnel from possible injury which will be caused by high Voltage, hot surface and rotating parts.*



LOW VOLTAGE INDUCTION MOTORS

1. FOREWORD	4
2. RECEIVING	4
3. WARNING	5
4. STORAGE	5
5. LOCATION	6
6. MOUNTING	6 ~ 8
7. POWER SUPPLY and CONNECTIONS	8 ~ 14
8. OPERATION	14 ~ 15
9. MAINTENANCE	15
10. MAINTENANCE OF BEARING	16
11. MAINTENANCE OF LUBRICATION	17 ~ 18
12. INSPECTION & MAINTENANCE SCHEDULE	19 ~ 21
13. TROUBLE SHOOTING	22 ~ 25
14. SERVICE	25

01 FOREWORD

This instruction manual describes and provides instructions for installation, operation and maintenance of induction motors.

These instructions do not support to cover all details or variations in equipment nor to provide for every possible contingency to be met in connection with installation, operation or maintenance. Should further information be desired or should particular problems arise which are not covered sufficiently, the matter should be referred to the nearest HD HYUNDAI ELECTRIC business office.

03 WARNING 

1. High voltage, hot surfaces and rotating parts of electrical machinery can cause serious or fatal personal injury and damage to property. Qualified personnel should perform proper installation, operation and maintenance. Recommendations to be familiarized with are NEMA MG2, the National Electrical Code, IEC60364(EN50110-1) and all sound local safety practices.
2. Before attempting maintenance or repair, avoid contact with energized circuits and disconnect and de-energize all power sources to the motor and to the necessary devices to avoid electrical shock.
3. Before motor is energized, avoid contact with rotating parts and ensure that shaft key is fully captive or removed.
4. When working near machinery with high noise levels, suitable protection must be used.
5. Automatic-reset thermal protection should not be used where unexpected automatic starting will be hazardous to personnel.
6. Proper safeguards or protective devices against possible failure of motor-mounted brake, especially on overhauling load applications should be provided and should not be by-passed. And a suitable enclosure should be provided against access to the motor or other un-authorized personnel.
7. Grounding of motor against fatal injury to personnel should be in accordance with the National Electrical Code and applicable local practice. Grounding cable and terminal should be securely crimped with proper crimping tools for safe grounding.
8. Repair of Explosion-proof motors should be made by Hyundai, U/L, CSA or other listed authorized service center to maintain those listings, safety and special feature in hazardous area. The use of non-explosion-proof motors in hazardous area is prohibited unless they are expressly intended for such use.

02 RECEIVING

1. Check motor & nameplate data (HP, Pole, Voltage and etc.).
2. Check for any damage or loose parts during transportation and stop commissioning if necessary.
3. Turn shaft by hand to check smooth rotation.
4. If shaft is clamped by locking device to prevent axial movement of heavy rotor during transportation, please remove it to run the motors and retain it for future transport.



CAUTION
If the motor is supplied with eyebolts for lifting purposes, make certain that these are tightened securely. Use these for lifting the motor only. Do not use these for lifting any equipment mounted to the motor. Note that the direction of lift should not exceed 15 degrees from the shank of the eyebolt.

04 STORAGE

1. When storing motors without immediate installation, to keep motors in best condition, make sure of a dry, clean, dust-free and low-vibration environment to avoid danger of bearing damage at rest.
2. Precautions should be taken to prevent the entrance of moisture, dust or dirt during storage especially for the winding and the bearings.
3. Before commissioning, check the insulation resistance of winding. In case of resistance values $\leq 1M\Omega$, the windings should be dried. For proper drying of motors, please refer to Part 8. OPERATION of this manual.

05 LOCATION

1. Drip-proof motors (IEC protection degree \leq IP23) are intended for use in well ventilated areas where the atmosphere is reasonably free of dirt, moisture and corrosion, and not intended for outdoor use.
2. Enclosed motors (IEC protection degree \geq IP44) are intended for operation where they are exposed to dirt, moisture, dust and most outdoor conditions.
3. Explosion-proof motors are designed for operation in hazardous areas classified by Underwriters' Laboratories, National Electrical Code, Canadian Standard Association and IEC60079.
4. Chemical heavy duty enclosed motors are designed for use in highly corrosive or excessive moisture locations.
5. Standard ambient condition of motors are rated for ambient temperatures of $-20^{\circ}\text{C}\sim+40^{\circ}\text{C}$ (-40°C with low temperature grease such as Beacon325) and altitudes below 1000m(3300feet) above sea level.

06 MOUNTING

1. Mount motors securely on a firm and flat base and make sure of solid foot or flange mounting. All motors with ball bearings and/or normal thrust can be side wall or ceiling mounted and can be vertically mounted for motors up to and including 326frame (IEC200L) size. For the recommendations of other applications, check nearest Hyundai office or sales agents.
2. Align motors accurately using flexible coupling for direct drive if possible. Because the balance of motors is made by half-key, the coupling or pulley must be half-key balanced. Mount or remove belt pulley or coupling only using the appropriate means and cover them with a safety guard and avoid excessive belt tensions. Consult drive or equipment manufacturer or Hyundai for drive recommendations.
3. The bolts for motor mounting and base assembly must be carefully tightened to prevent change in alignment and possible damage to the equipment applying the recommended tightening torques shown in the table below. Use the recommended torques for medium carbon steel bolts identified by three radial lines at 120 degrees on the head and use 50% of the recommended torques for low carbon steel bolts with no ID marks. In case of motors with 8 holes in feet, these 8 holes are used for the application of dual frame sizes. Only 4 holes are used for mounting in accordance with outline drawing.

Bolt Size	Tightening Torque (Nm)	
	Steel (8.8)	Brass
M5	8.0	2.9
M6	10.8	4.9
M8	20.7	9.8
M10	42.4	19.7
M12	73.9	34.5
M16	177.4	82.8

※The tolerance of tightening torques is $\pm 10\%$.

06 MOUNTING

4. If bases are removed from enclosed motors having bolt-on base, the enclosure must be maintained by plugging or closing the bolt holes and do not replace the base bolts in the frame with the base removed.
5. In case of enclosed motors having drain plugs, remove them from the end shields or frame in the bottom side for outdoor use or in other high moisture areas.
6. Because low voltage motors per IEC are components for installation in machinery as defined in Machinery Directive89/392/EEC, commissioning is prohibited until conformity of the end product with this directive has been established per EN60204-1 for European country.
7. The application of pulleys, sheaves, sprockets and gears on motor shaft is described in NEMA standard MG1-14.7. The application of V-belt sheave dimensions to AC motors is shown in NEMA MG1-14.42. The V-belt sheave diameters should not be less than the values in the table below and the sheave width should not be wider than the maximum width per the equation below.

Horsepower				V-belt Sheave(inch)	
Synchronous Speed, RPM				Conventional	Narrow
				A,B,C,D,E	3V,5V,8V
3600	1800	1200	900	Minimum Pitch Diameter ▶	Minimum Outside Diameter ◀
1.5	1	0.75	0.5	2.2	2.2
2-3	1.5-2	1	0.75	2.4	2.4
-	3	1.5	1	2.4	2.4
-	-	2	1.5	2.4	2.4
5	-	-	-	2.6	2.4
7.5-10	5-7.5	3-5	2-3	3.0	3.0
15	10	7.5	5	3.8	3.8
20-25	15	10	7.5	4.4	4.4
-	20	15	10	4.6	4.4
-	25	-	-	5.0	4.4
-	30	20	15	5.4	5.2
-	40	25	20	6.0	6.0
-	50	30-40	25-30	6.8	6.8
-	60	-	-	7.4	7.4
-	-	50	40	8.2	8.2
-	75	-	-	9.0	8.6
-	-	60	-	9.0	8.0
-	-	-	50	9.0	8.4
-	100	-	-	10.0	8.6
-	-	75	60	10.0	10.0
-	125	-	-	11.5	10.5
-	-	100	-	11.0	10.0
-	-	-	75	10.5	9.5
-	150	-	-	-	10.5
-	-	125	100	12.5	12.0
-	200	-	-	-	13.2

06 MOUNTING

- ▶ Maximum sheave width = $2(N-W) - 1/4"$
- ◀ Maximum sheave width = $(N-W)$
- # N-W (E for IEC) = the usable shaft length

Sheave ratios greater than 5:1 & center to center distances less than the diameter of large sheave should be referred to Hyundai.

8. Make necessary ventilation passage for the best operation of motors. In case of belt pulley, ventilation opening of rim of pulley is essential for motors.

The ventilation must not be obstructed. The distance between ventilation openings of motors and wall or obstacle should be maintained by minimum 25mm (1inch) and ventilation diameter divided by 4. Motors with shaft ends pointing upward are to be provided with a cover by the customer to prevent foreign materials from falling into the ventilation or openings.



In all cases, no surrounding structure should obstruct normal flow of ventilation air through or over the motor

07 POWER SUPPLY and CONNECTIONS

1. Wiring of motor, control, grounding and overload protection should be in accordance with the National Electrical Code and all sound local building codes or practices only by qualified technical personnel. Proper earthing of motor frames and insulation of live parts should be strictly observed to avoid electrical shock to personnels.
2. Power supply should agree with nameplate voltage and frequency and permissible variations of power supply are $\pm 5\%$ for frequency, $\pm 10\%$ for line voltage and $\pm 10\%$ for combined variation to avoid elevated temperatures and effects on the electromagnetic compatibility. (IEC motors : $\pm 2\%$ for frequency, $\pm 5\%$ for line voltage per IEC60034-1, EN60034-1 for multi-voltage motors)
3. Thermally-protected motors to prevent excessive temperature rise or overload have two terminals of protectors (P1,P2) and should be connected to the control panel according to the connection diagram inside of the conduit box.
Manual-reset protectors can be reset after motor is cooled by pressing the reset button and Automatic-reset protectors(no external button) reset automatically after motor cooled. Do not use Automatic-reset protectors where unexpected automatic starting will be dangerous to personnel.



Explosion proof motors equipped with thermostats must be connected to the motor control in order to maintain the factory warranty , and for the installation to comply with CSA, UL, NFPA, WCE and other governing regulations.

07 POWER SUPPLY and CONNECTIONS



Do not use automatic reset protected motor where unexpected start could cause injury to operating personnel.

4. Dual voltage motors can be connected for the desired voltage using the connection diagram inside of the conduit box.
5. Minimum clearances between un-insulated live parts and between such parts and earth must not be below 8mm at Volts \leq 550V, 10mm at Volts \leq 725V, 14mm at Volts \leq 1000V.
Because no presence of foreign objects, dirt or moisture is admitted in the conduit box, close unused cable entrance holes and the box itself in a dust- and water-tight manner.
6. For motors with brakes, check satisfactory functioning of brake before commissioning.
7. Standard connection diagrams for three phase motors without any accessories are shown as below and rotation can be changed by interchanging any two line leads.
Use appropriate cable terminals with proper crimping tools and protective and permanent conductor connection without loose wire ends. It is important for safety.

(1) 3 Leads, Single voltage

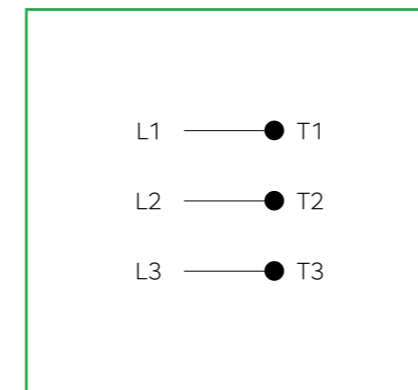

(2) 6 Leads, Dual voltage & voltage ratio 1 to $\sqrt{3}$, Single voltage

1) Direct-on-line Start & Run

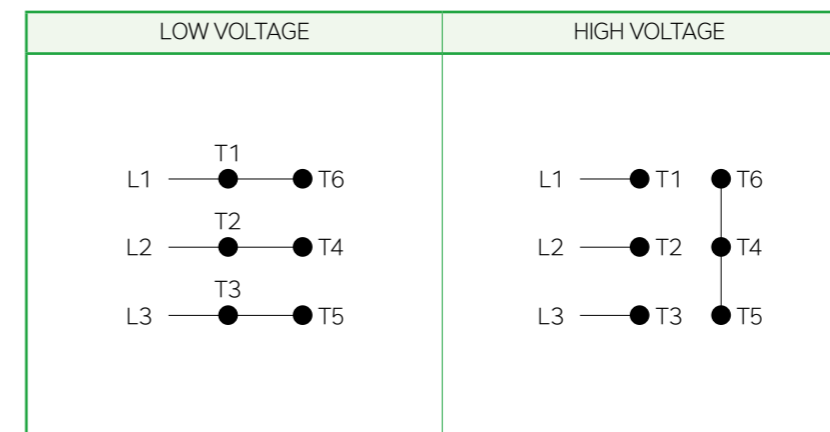

2) Wye Start & Delta Run (Low voltage only)

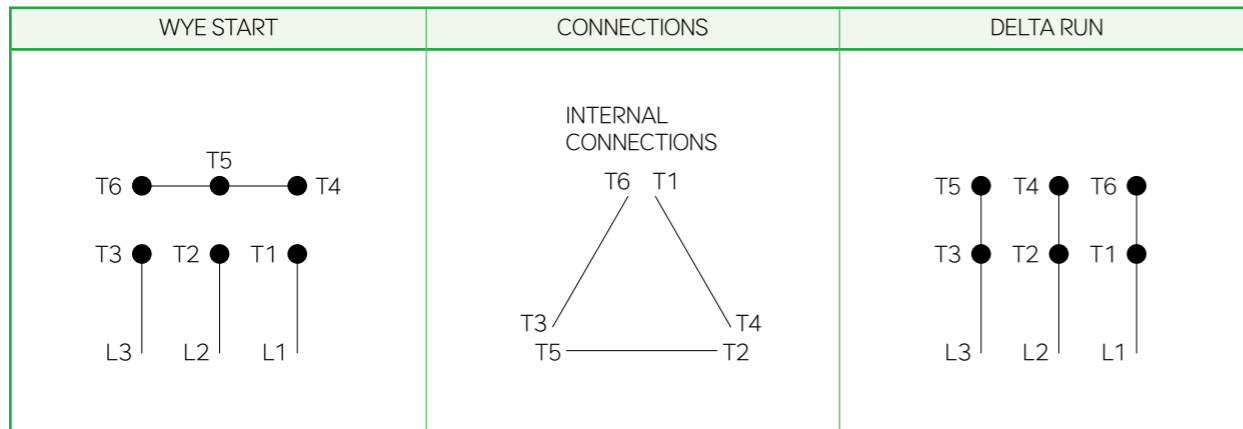

3) Control for Wye Start & Delta Run (Low voltage only)

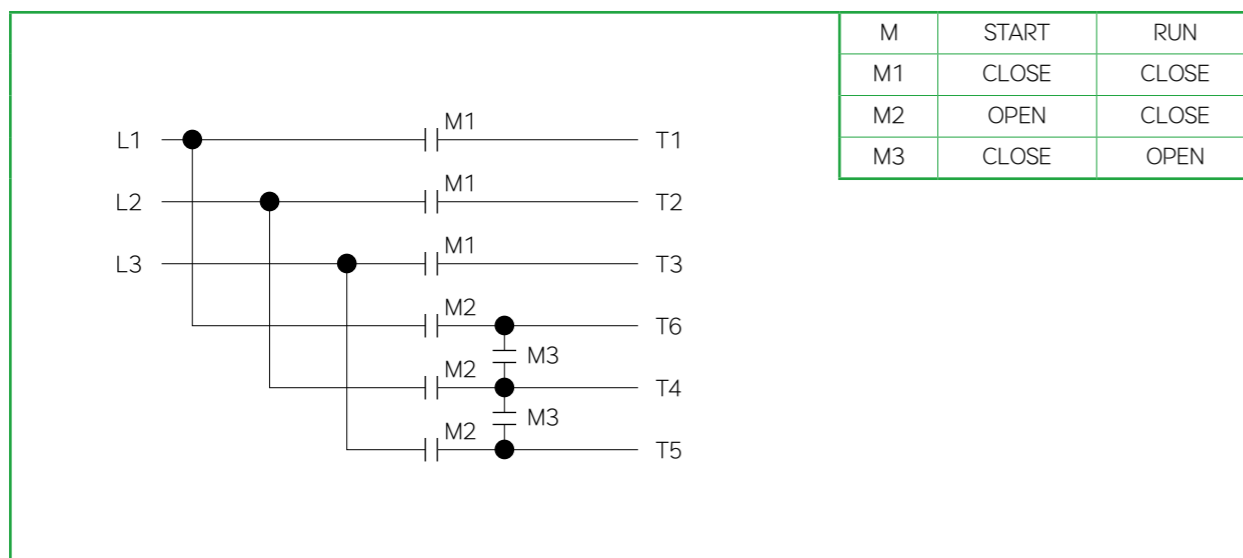

(3) 9 Leads, Dual voltage & voltage ratio 1 to 2, Wye interconnection

1) Direct-on-line Start & Run

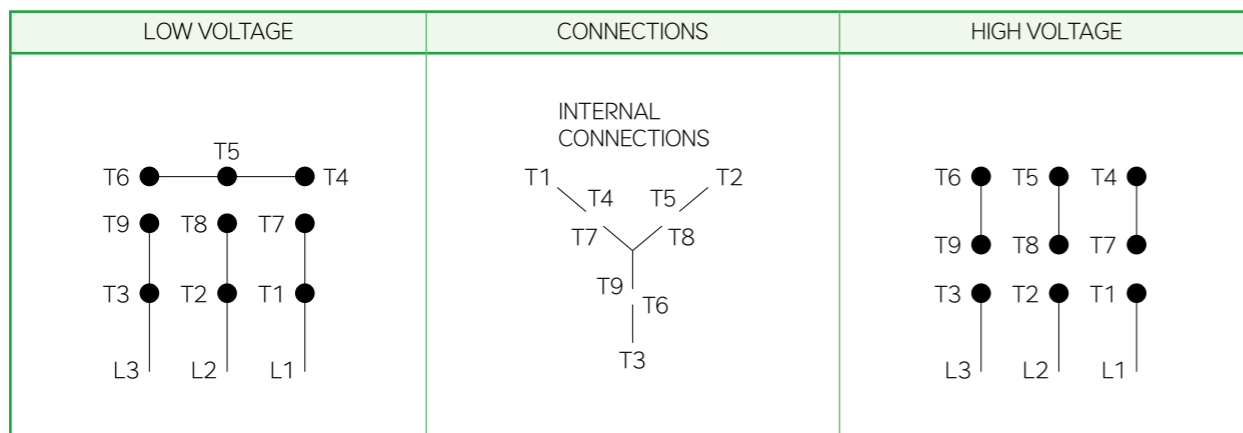

2) Control for Wye Start & Delta Run (Low voltage only)

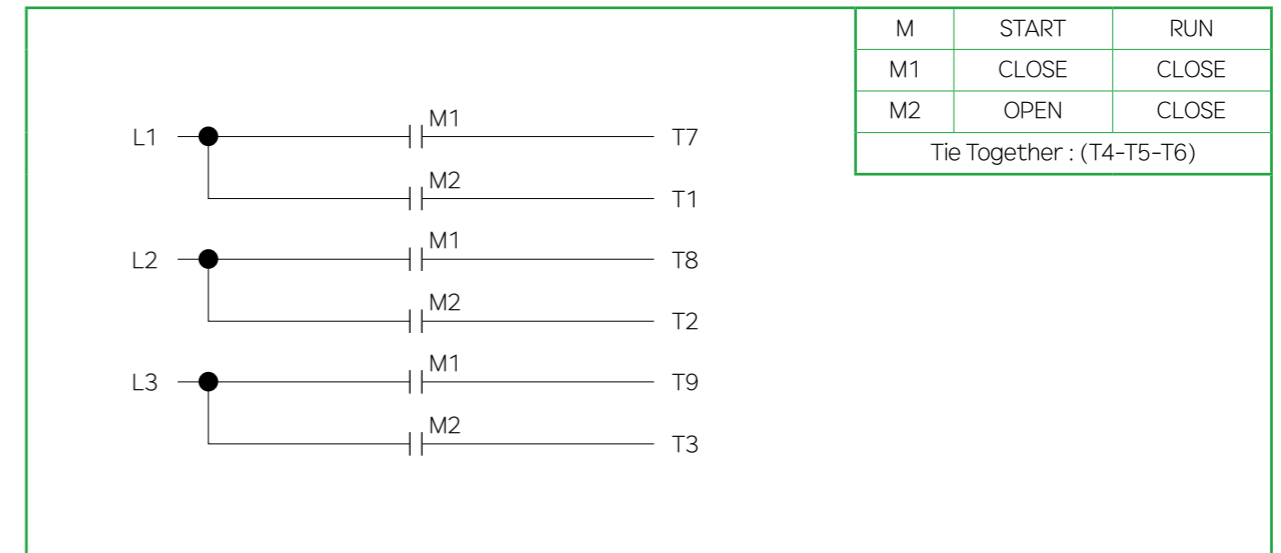

(4) 12 Leads, Dual voltage, Delta interconnection

1) Direct-on-line Start & Run

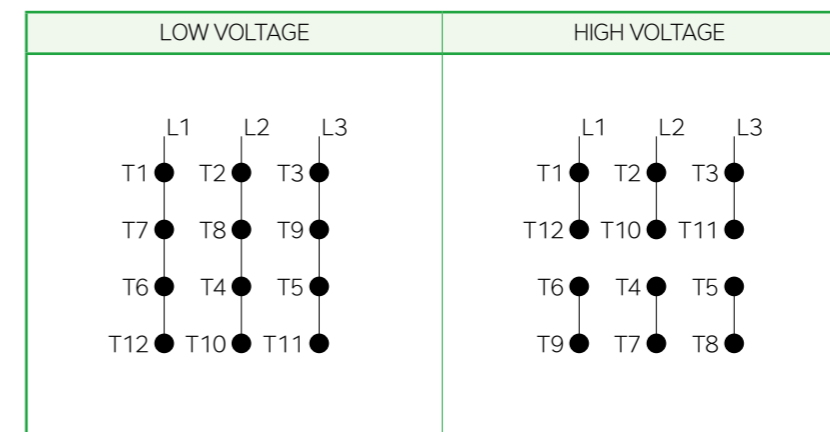

2) Wye Start & Delta Run (Low voltage only)

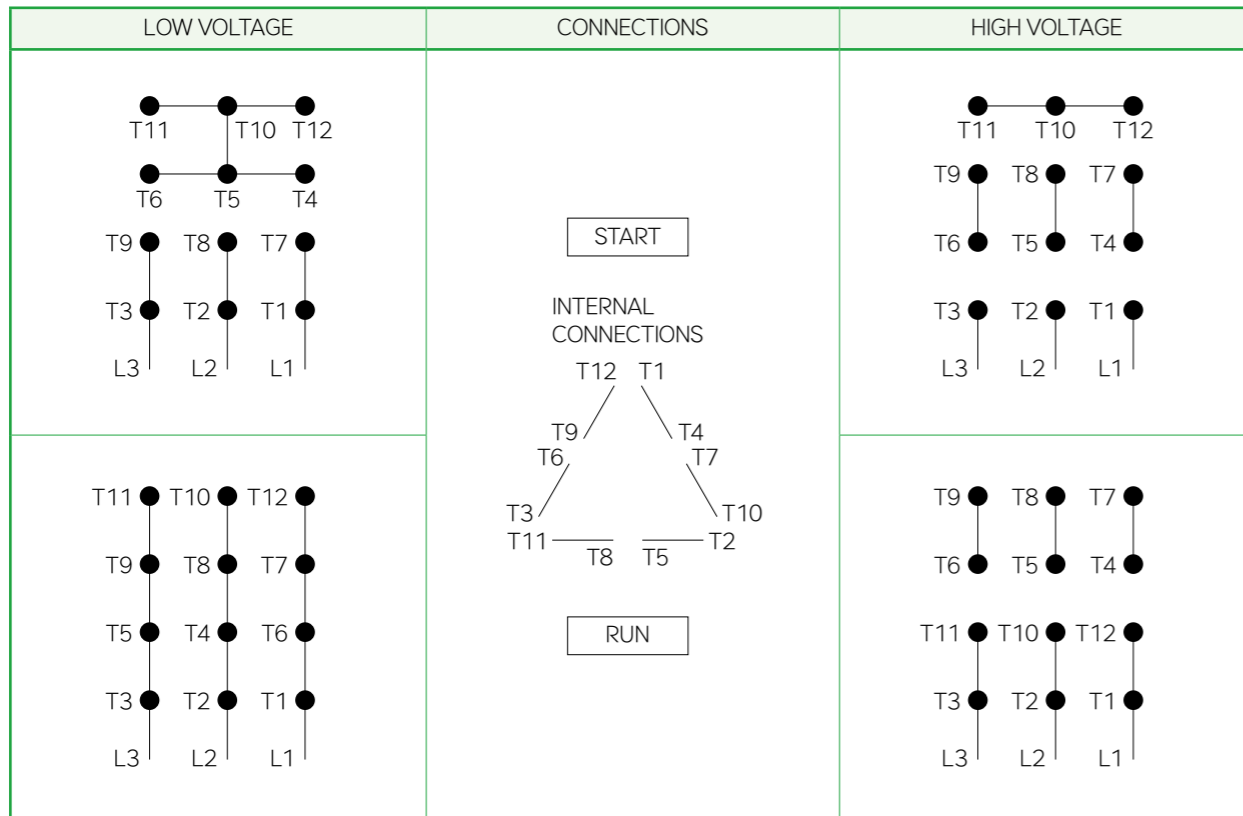

3) Control for Wye Start & Delta Run (Low voltage)

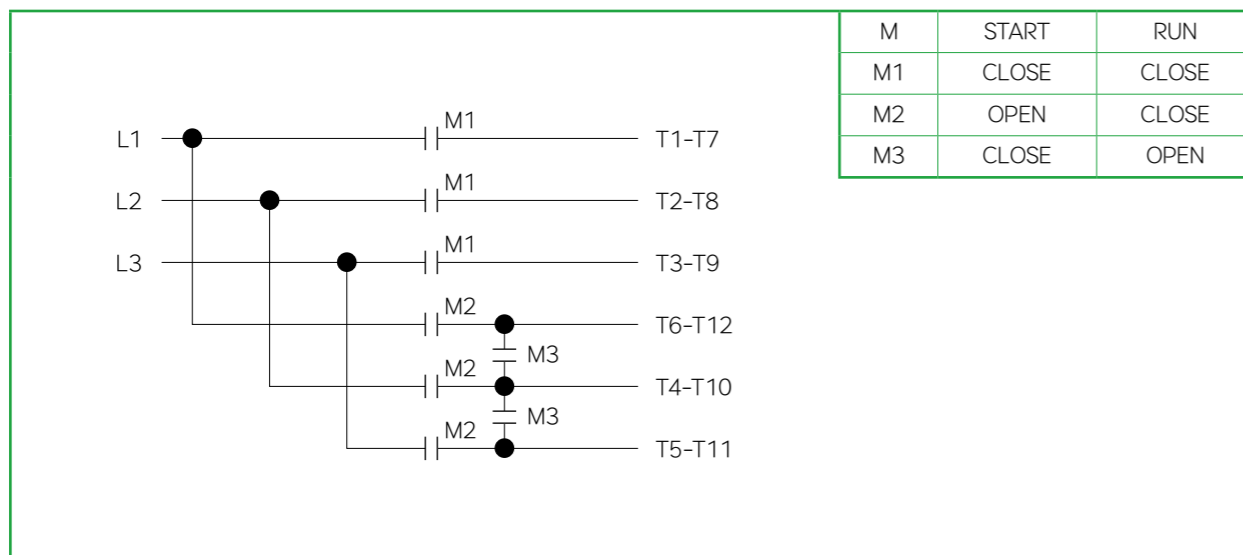

4) Control for Wye Start & Delta Run (High voltage)

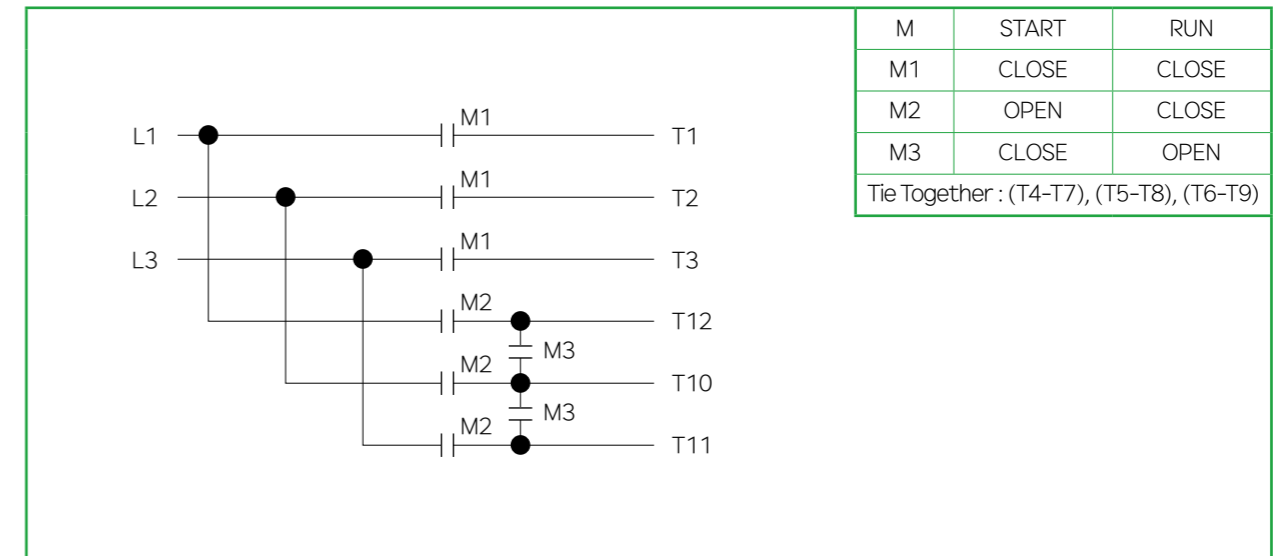

5) Part winding start (Low voltage only)

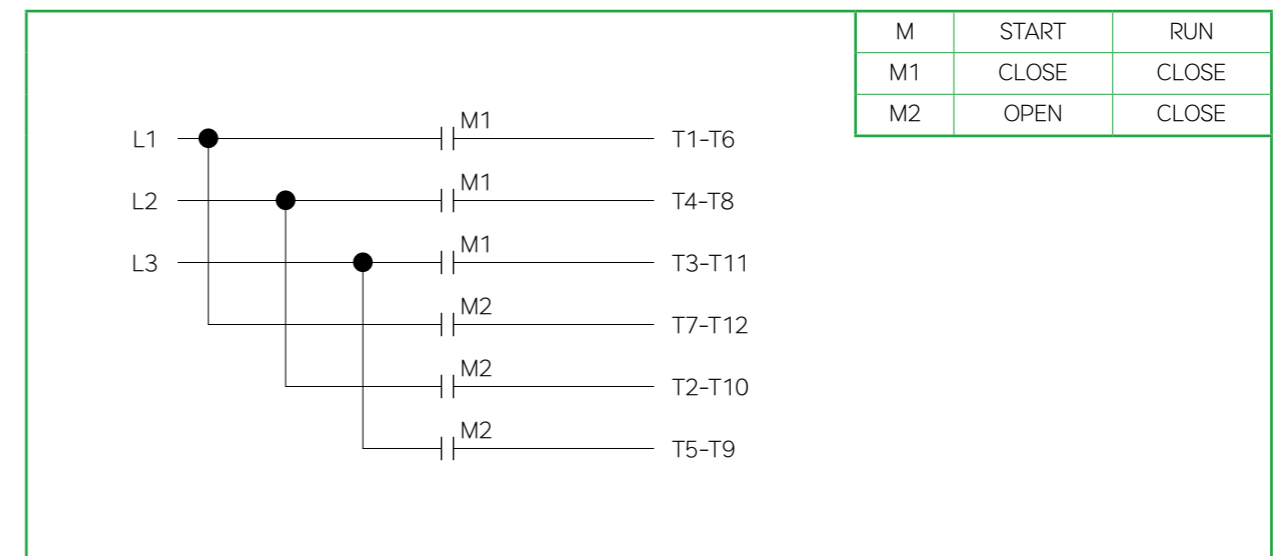

* For part winding start with magnetic contactor, M2 contactor should be closed within two seconds after M1 contactor is closed.

* Part winding start at low voltage is satisfactory only for 4pole and above. (4p, 6p, 8p and above)

07 POWER SUPPLY and CONNECTIONS

8. To connect the external power cable to terminal block in terminal box, the nuts on terminal block must be carefully tightened in accordance with the recommended tightening torque values specified in the table below.

Terminal block Type	Frame Assignment	Stud bolt size	Recommended Tightening torque (Nm)	Vendor's Designation
Maker Standard	FR.90	M4	1.2~2.0	-
	FR.100~132	M5	2.0~3.2	-
	FR.160~180	M6	3.0~5.0	-
	FR.200~225	M8	6.0~10	-
	FR.200~225	M10	10~20	-
	FR.250~280LL	M12	16~25	-

※ The tolerance of tightening torques is ±10%

※ Frame assignment on this table is standard arrangement. It may be different on the actual application.

08 OPERATION

- If the motor has been stored for an extensive period or in a damp location, check the insulation resistance of stator winding & bearings.
If the resistance of stator winding is lower than 1Mega Ω, dry out motors thoroughly with maximum drying temperature of 85°C (185°F) in one of the following ways.
 - Dry the stator in an oven until the insulation resistance is constant for a one-half hour period.
 - Enclose the motor with a canvas or similar covering leaving an opening at the top for moisture to escape. Insert heaters or lamps with care to avoid localized damage due to too closer heating to the winding and leave them until the insulation resistance is constant for a one-half hour period.
 - With the rotor locked, apply approximately 10% of rated voltage and increase current gradually through the windings until temperature measured with thermometer reaches 85°C(185°F; Do not exceed this limit). Maintain 85°C until the insulation resistance is constant for a one-half hour period.
Turn the shaft by hand to check the bearing and it may be necessary to re-grease or change rusted bearings depending on the period and condition of storage.
- Operate motor at no load (disconnected load) and check rotation (without key if uncoupled) for free running. Interchange any two leads to change direction of rotation for three phase motor.
- Connect load and operate for an initial period of at least one hour to check any unusual noise, vibration or hot spots and check those items periodically even after successful start-up. Acceptable vibration severities can be decided by NEMA MG1-2011 Part7 (140≤NEMA FRAME: 2.4 mils pk-pk, 0.15 in inch/sec pk) and IEC60034-14 (56≤H: 2.8 in mm/sec rms.) under no load and uncoupled condition.

08 OPERATION

- Check operating current against nameplate current. Be careful not to exceed the value of nameplate amperes multiplied by the service factor under continuous load.
- When 208-230/460V motors with alternate voltage of 200V at 1.0 SF are used on 200V, the % slip of motors will increase approximately 30% and torques will be reduced by approximately by 20 to 30%. Therefore, user should check and determine that motors will start and accelerate without injurious heating and with adequate torque.

09 MAINTENANCE

- INSPECT motor regularly and keep motor clean and dry. In case of heavy dirt or deposits, clean air channels periodically.
- If the period of storage or stop of running of motor is more than one month, turn the shaft by hand to check the smooth rotation of bearings every one month and check the insulation resistance of winding every three months as minimum.
- Special features of Explosion-proof motors should be maintained in accordance with U/L, CSA or other authorized standard in hazardous area.
Therefore, repair of Explosion-proof motors is recommended to be made by Hyundai, U/L, CSA or other listed authorized service centers to maintain those listings, safety and special features.
- In order to clean stator windings, use a soft brush and a slow acting solvent (if necessary) without affecting on coils, insulation and varnish in a well ventilated room for safety.
- The V-seal should be handled and maintained according to the below.
 - If there is influence from sunlight, UV exposure and ozone during the motors had been stored and used, the V-seal have been aged and damaged.
These effects can reduce the performance and lifetime of the V-seal.
 - To slow ozone aging, V-seal should be kept away from direct or reflected sunlight and electrical equipment that may generate ozone. Excessive heat build-up in the storage area and exposure to ozone can cause premature deterioration of the V-seal.
 - The condition of V-seal should be checked during the maintenance/repair period.
In case of V-seal, it should be replaced according to the condition because this is consumable part. It is difficult to define the lifetime of the V-seal because of various environmental factors, but HE are predicting a lifetime of about two years in general condition. If user want to maintain the lifetime and performance of V-seal a little longer, it is helpful to apply grease periodically on the surface of V-seal. (The recommended grease application period is 3 months. If it is difficult to comply, apply it at least during the resupply period. Also rotate the shaft slowly at least 10 revolutions by hand when applying grease on the surface of V-seal.)
 - If the motor has not been in operation for a long period of time, it is recommended to be stored indoors, and V-seal must be covered with a cover to prevent direct sunlight when stored outdoors.

1. Mounting

Electrical machines fitted with rolling-contact bearings mentioned above are subject to the following instructions supplementing and modifying the operating instructions of the machine:

The locating bearings are deep-groove ball bearings for horizontally mounted machines.

These bearings may also be in pairs with cylindrical roller bearings in the case of bearings that are not guided radially and are prevented from rotating by compression springs.

The locating bearings for vertically mounted machines are angular-contact ball bearings of type range 72 or 73 (angular-contact ball bearings with increased axial fixation see supplementary operating instructions).

The floating bearings are deep-groove ball bearings or cylindrical roller bearings.

In case of deep-groove ball bearings as floating bearings, the axial play is compensated by means of compression springs.

2. Thrust bearing

Thrust bearing consists of two angular contact ball bearings in the arrangement as shown in a diagram on next page. This is called DB arrangement and bearing number on name plate is indicated with suffix DB.

(Single angular contact ball bearing has suffix B only.)

DB arrangement is to be maintained as in diagram on below in case of reassembly of bearing or horizontal and vertical mounting change.

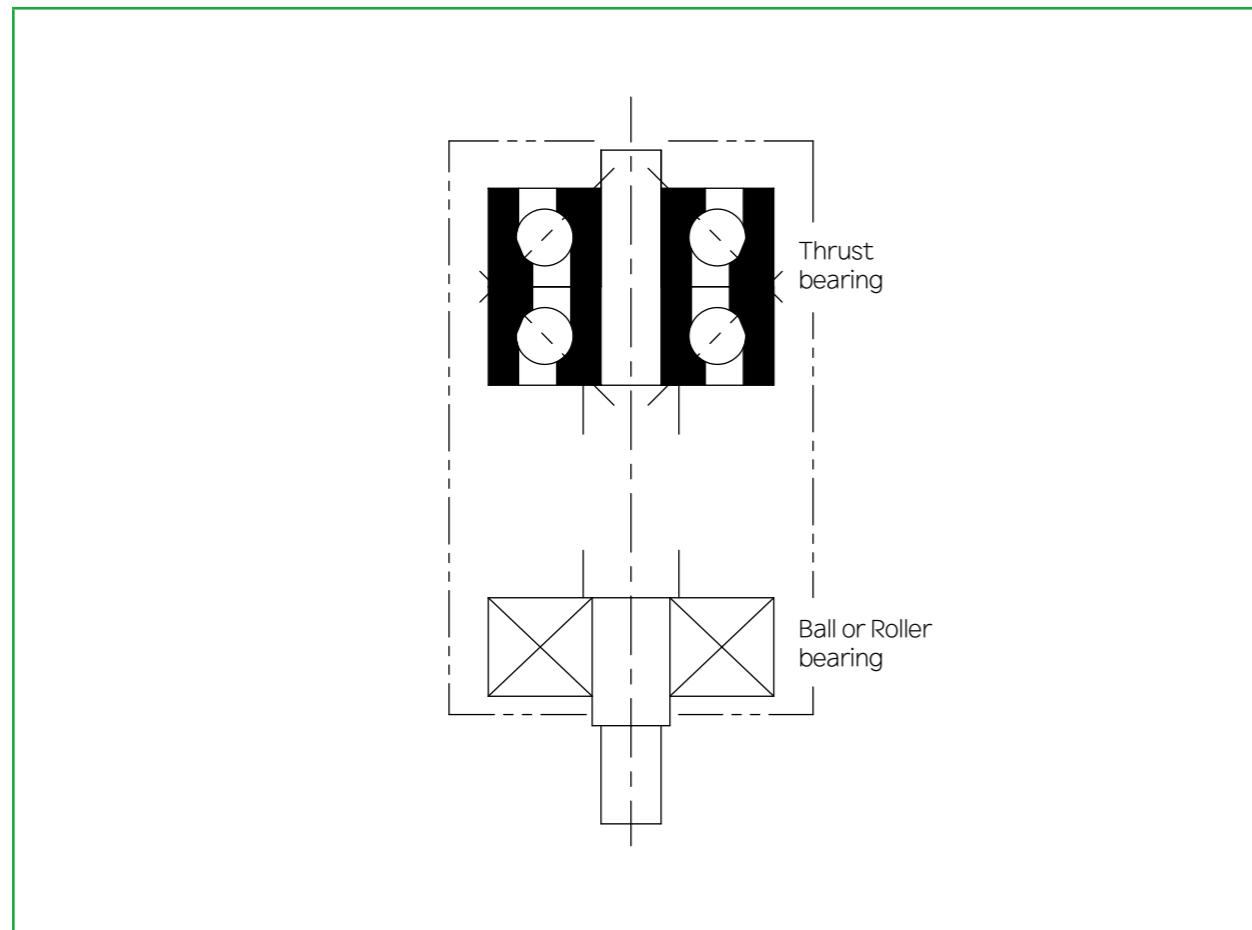

1. Double shield and pre-lubricated ball bearing motors without grease fittings are adequately greased for life at the factory and do not need re-lubrication.

2. Motors with re-greasing facilities are shipped with grease for initial running and should be checked and re-lubricated periodically depending on the type of service (see below table) to maintain maximum bearing life. Do not lubricate excessively or too frequently to prevent bearing damage and grease leakage.

No.	BRG. No.	Amount of Initial Charge	Amount of Re-lubrication	Interval of Re-lubrication (Months)			
				2P	4P	6P	8P
1	6202	3 g	2 g	3	6	6	6
2	6203	3 g	2 g	3	6	6	6
3	6204	6 g	3 g	3	6	6	6
4	6205	7 g	4 g	3	6	6	6
5	6206	10 g	5 g	3	6	6	6
6	6207	15 g	6 g	3	6	6	6
7	6208	19 g	7 g	3	6	6	6
8	6211	33 g	10 g	3	6	6	6
9	6212	42 g	12 g	3	6	6	6
10	6213	50 g	14 g	3	6	6	6
11	6226	334 g	46 g	-	2	2	2
12	6307	24 g	8 g	3	6	6	6
13	6309	46 g	12 g	3	6	6	6
14	6310	60 g	15 g	3	6	6	6
15	6311	94 g	20 g	3	6	6	6
16	6312	94 g	20 g	3	6	6	6
17	6313	116 g	23 g	3	6	6	6
18	6314	140 g	26 g	3	6	6	6
19	6315	170 g	30 g	2	6	6	6
20	6316	200 g	33 g	2	6	6	6
21	6317	240 g	37 g	1	6	6	6
22	6318	280 g	40 g	-	6	6	6
23	6319	324 g	45 g	-	6	6	6
24	6320	396 g	50 g	-	5	5	5
25	6322	517 g	60 g	-	4	4	4
26	6324	634 g	71 g	-	3	3	3
27	6326	777 g	81 g	-	2	2	2
28	7213B	90 g	28 g	3	6	6	6
29	7213DB	180 g	55 g	3	6	6	6
30	7226DB	813 g	184 g	-	2	2	2
31	7313B	220 g	46 g	3	6	6	6
32	7313DB	440 g	92 g	3	6	6	6
33	7314B	263 g	52 g	3	6	6	6
34	7314DB	526 g	105 g	3	6	6	6
35	7315A	327 g	59 g	2	6	6	6

No.	BRG. No.	Amount of Initial Charge	Amount of Re-lubrication	Interval of Re-lubrication (Months)			
				2P	4P	6P	8P
36	7316A	390 g	66 g	2	6	6	6
37	7316B	370 g	66 g	2	6	6	6
38	7316DB	742 g	133 g	2	6	6	6
39	7317A	465 g	74 g	-	6	6	6
40	7318B	515 g	80 g	-	6	6	6
41	7318DB	1030 g	163 g	-	6	6	6
42	7319B	600 g	90 g	-	3	3	3
43	7319DB	1195 g	180 g	-	6	6	6
44	7320B	700 g	100 g	-	5	5	5
45	7320DB	1400 g	202 g	-	5	5	5
46	7322DB	1290 g	240 g	-	4	4	4
47	7324DB	1665 g	286 g	-	3	3	3
48	NU213	45 g	14 g	2	5	5	5
49	NU218	73 g	24 g	-	3	3	3
50	NU222	133 g	38 g	-	2	2	2
51	NU313	103 g	23 g	2	5	5	5
52	NU314	120 g	26 g	1	4	4	4
53	NU316	110 g	33 g	1	4	4	4
54	NU317	200 g	37 g	-	4	4	4
55	NU318	150 g	41 g	-	3	3	3
56	NU319	270 g	45 g	-	3	3	3
57	NU320	320 g	50 g	-	3	3	3
58	NU322	255 g	60 g	-	2	2	2
59	NU324	350 g	71 g	-	2	2	2
60	NU326	375 g	81 g	-	1	1	1
61	NU332	645 g	116 g	-	-	1	1

- For re-lubrication, clean the grease nipple and press in the exact amount of grease as in the table above by using the grease gun. Take a note that re-lubrication should be carried out while motor is operating. After re-lubrication, the bearing temperature will rise but, it will drop back to the normal value when the grease has reached its normal service viscosity.
- As long as lubrication is carried out in accordance with the table above, bearing will show no problem with its operation even in the case that re-lubricated grease is not observed at the drain plug, because the old grease is accommodated in the chamber of bearing housing. Remove the old grease when overhauling the machines.
- In case of initial or replacement charge, put a third of the grease amount of initial charge in the bearing and the rest amount of grease in the chamber of bearing housing.



WARNING Make sure all guards are in place and stay clear of all moving parts.

- In case of lubrication for TEFC motors, remove the plastic caps on the fan cover for access to the grease fittings.

1. Abbreviation used in interval

- A = Daily Inspection
- B = Weekly Inspection
- C = First Inspection, no later than 6 months
- D = Following Inspection, no later than two (2) years. (when required, dismantle the machine)

2. General

Interval				Inspection and Maintenance Work	Criteria	Counter measure
A	B	C	D			
○				Check the machine for irregular noise and excessive vibration. (P13. 8-3)	Refer to the approval motor document	If the irregular noise and excessive vibration occur, Refer to trouble shooting (p.22~23)

3. Anti-friction bearing

Interval				Inspection and Maintenance Work	Criteria	Counter measure
A	B	C	D			
○				Where possible, measure and record the bearing temperature.	-	-
				Relubricate the grease lubricated bearing. Oil-lubricated bearing: Change the oil. Clean and inspect the bearings. For the intervals of maintenance work, see the lubrication instruction plate on the machine.	Refer to the lubrication name plate	-
		○	○	Check the shaft sealing rubber ring for deterioration.	-	Visual check : replace the seal when the deterioration and discoloration occur.

4. Enclosure

Interval				Inspection and Maintenance Work	Criteria	Counter measure
A	B	C	D			
		○	○	Check to see that the enclosure is not clogging (blocking) the machine ventilation.	-	Clean the external cooling air paths
		○	○	Check the gaskets for deterioration.	-	Visual check : replace the seal when the deterioration occur.
		○	○	Check the enclosure for any deformities or damage.	-	Repair or replace the enclosure
		○	○	Check the noise-suppression material for damage.	-	Replace the noise-suppression material
			○	Drain the drain plug, when provided.	-	-
		○	○	Replace and clean the air filter, when provided.	-	-
		○	○	Check the clearances to rotating parts.	Uniform on all side	Adjusting the clearance.
		○	○	Check the enclosure for corrosion.	-	Visual check : Touch up or re-painting
			○	Check the electrical and grounding connection tightening.	Tightening torque (p6)	Re-tightening

5. Squirrel-cage rotor

Interval				Inspection and Maintenance Work	Criteria	Counter measure
A	B	C	D			
		○	○	Clean the winding, as far as possible.	-	-
			○	For totally enclosed machine, clean entire winding if required.	-	-
			○	For the open enclosed machine: Clean entire winding and cooling air paths including the core packs-air duct.	-	-
			○	Check the fracture or deformation of cage bars and end rings.	No fracture or deformation	Repair or replacement
			○	Check axial displacement.	Refer to the approval motor document	Re-alignment
			○	Check the end ring and support ring assembled condition.	No gap between end ring and support ring	Repair or replacement

6. Shaft and coupling

Interval				Inspection and Maintenance Work	Criteria	Counter measure
A	B	C	D			
		○	○	Check and adjust the belt tension.	Refer to the belt manual.	
		○	○	Check rotor alignment.	-	Re-alignment
			○	Check the balancing weight for tightness.	No looseness	Inspect / reassemble
			○	Check all coupling bolts and locking elements for tightness.	Refer to the coupling manual.	
			○	Check the oil leakage of gear coupling.	Refer to the coupling manual.	
			○	Check the shaft keys for tightness.	No looseness	Inspect / reassemble

7. Monitoring instruments

Interval				Inspection and Maintenance Work	Criteria	Counter measure
A	B	C	D			
			○	Check the installation condition of monitoring instruments and device for proper function.	Check if monitored value is normal at the control panel.	Confirm the wire connection.

Abnormality	Probable Cause	Remedy
Rotation in reversal direction	Phase reversal	Two phases of U,V,W(or R,S,T) at starter or motor terminal are to be changed..
Motor body overheated	1. Overload	Load is to be reduced. (to rated current)
	2. Overcurrent due to voltage drop	a. A check is to be made with a voltmeter power source Voltage is to be raised. b. Load is to be reduced.
	3. Excessive iron loss due to overvoltage	A check is to be made with a voltmeter power source. Voltage is to be reduced.
	4. Cut line or imperfect contact in one phase	To be reconditioned.
	5. Short-circuiting and grounding of coil	Resistance and current are to be checked and reconditioned.
	6. Contact between stator and rotor	Judgment can be made according to noise; bent shaft, bearing, etc., are to be corrected.
	7. Inadequate ventilation due to dust	Cleaning is to be carried out.
Vibration	1. Unbalance of rotor a. Bending of shaft b. Loose joint c. Residual unbalance d. Critical speed of shafting e. Dust attached to rotor f. Imperfect connection between coupling and shaft	To be repaired. To be tightened by bolts securely. To be readjusted. To be cleaned. To be reconditioned.
	2. Improper magnetic center	To be reconditioned.
	3. Defective bearing	Refer to the "Bearing" section.
	4. Coupling deflection	To be reconditioned.
	5. Abnormal contact between shaft and stationary part, such as end cover, etc.	a. To be checked by turning manually. b. To be disassembled for detecting defects.
	6. Unsatisfactory contact of brush	Brush is to be checked for contact.
	7. Improper alignment	To be reconditioned.
	8. Sinking of foundation	To be reconditioned.
	9. Transmission of vibration from combined machine	Insulation for vibration.
	10. Unequal pitch of claw coupling	Reconditioning of pitch.
	11. Improper bush of flexible coupling	Reconditioning of pitch.

Abnormality	Probable Cause	Remedy
Noise	1. Disagreement of air gap	Causes are to be detected; repairs are to be made.
	2. Single-phase operation	Causes of single-phase operation such as line cutting and imperfect contact are to be detected; repairs are to be made.
	3. Short-circuits of layer and phase of stator coil and rotor coil	To be reconditioned.
	4. Abnormal contact between shaft and stationary part such as end cover	1. A check is to be made by turning manually. 2. To be disassembled for inspection.
	5. Unsatisfactory foundation and installation	Readjustment of installation.
	6. Loose bolts for foundation	Foundation bolts are to be tightened.
	7. Gap between foundation and base	Reconditioning of installation.
	8. Resonance with foundation	Readjustment of foundation.
	9. Crackings at brazed joint rotor bar and end ring	To be disassembled and defective parts are to be repaired.
Unbalance of phase current	1. Voltage unbalance	Power source and lines are to be checked and balanced.
	2. Single-phase operation	Line cutting and improper contact are to be reconditioned.
	3. Secondary circuit	1. Rotor shaft coil resistance is to be measured and reconditioned. 2. Contact of brush or short-circuit ring is to be checked. 3. A check is to be made on ending contact of a squirrel cage motor.
Flaking (a) Flaking of rolling elements	1. Excess of tightening allowance	1. Care should be taken on shaft at time of assembling and on bearing box at time of matching.
	2. Erroneous selection of clearance	2. Clearance is to be reinspected.
	3. Minus operating clearance	3. Care should be taken at time of assembly.
	4. Thermal expansion	
(b) Local flaking of a race	1. Inclusion of dust and other foreign substances or rust, bruises	4. Examination of working condition.
(c) Flaking all over a race (d) Flaking on component parts opposite to a race	1. Shaft or bearing box is distorted elliptically.	Machining accuracy and tightening of bearing box are to be checked.
	2. Improper tightening	
	3. Inaccuracy due to improper matching	
	4. Deterioration with time	

Abnormality	Probable Cause	Remedy
(e) Flaking all over around track center (f) Flaking across a race	Abnormal thrust load 1. Shaft bending 2. Oblique fitting of outer and inner rings	Design of bearing system is to be checked.
(g) Flaking similar to pitting on a race	1. Vibration during stoppage 2. Rust	Examination of working condition.
Seizing (a) Race ring and rolling discolored and turned soft (b) Damage	1. Inadequate clearance 2. Inadequate lubrication 3. Improper overload of lubricant	Proper clearance is to be provided. Oil amount of lubricant is to be checked. Reconsideration of working condition and handling.
Breakage (total or partial) (a) Fracture (b) Cutting	1. Advancement of flaking caused by shock and below 2. Great tightening allowance & large round corner of fitted part	Careful handling. Examination of tightening. Examination of machining accuracy of shaft & bearing housing.
Breakage of retainer (a) Fracture (b) Nonuniform abrasion (c) Wear of pocket section (d) Biting-off	1. Moment load 2. Rotation at shaft speed 3. Inadequate lubrication 4. Inclusion of foreign substances	Careful handling and reconsideration of working condition Examination of oil supply and lubricant.
Rust (a) Rust formed all over surface (b) Rust on local place (c) Contact erosion on joint surface	1. Unsatisfactory condition of storage 2. Left alone 3. Inadequate cleaning 4. Rust-preventive reagent 1. Unsatisfactory packing 2. Condensation 1. Inadequate allowance of tightening 2. Change in load	Inspection of storage room. Careful handling. Examination of rust-preventive reagent. Reexamination of machining of shaft & bearing housing. Reexamination of working condition.
Wear (a) Abnormal wear of race and rolling element (b) Abnormal wear of retainer	1. Inclusion of foreign substances 2. Occurrences of wear Inadequate lubrication	Examination of lubrication and oil supply.
Electrode (a) Crater-shaped depression and corrugated scars	Passage of current	Examination of design of bearing system.

Abnormality	Probable Cause	Remedy
Dent and scratch (a) Indentation (on a race, etc.) (b) Aventurine hardening (c) Dents given during handling (d) Scratches during assembly	Dust and foreign substances pressed between race and body Careless handling (dropping, etc.)	Examination of handling and assembling conditions Careful handling Careful assembling
Smearing biting-off on a race and rolling element	1. Inadequate lubrication 2. Skewing of rolling element 3. Selection of lubricant	Examination of lubricant and lubricating condition
Creep wear of outer and inner ring surface, sliding and discoloring	1. Inadequate tightening allowance 2. Inadequate tightening of sleeve	1. Examination of tightening 2. Examination of machining accuracy of shaft and bearing box 3. Examination of design

14 SERVICE

1. HD Hyundai motors should be serviced by qualified personnel using proper tools, equipment and genuine HD Hyundai renewal parts.

2. When ordering spares or renewal parts, please specify information on the nameplate such as model No., serial No., HP(or kW), frame size and pole.

Memo

Memo

EMPORIUM ENERGY, C.A.

Primer Distribuidor Autorizado de HD Hyundai Electric en Venezuela

CONTÁCTENOS

www.emporiumve.com

ventas@emporiumve.com

Vía Polígono de Tiros, Centro Industrial Polígono,
Galpón 6, Oficina 2 · Barcelona 6001
Edo. Anzoátegui, Venezuela